

5/2024

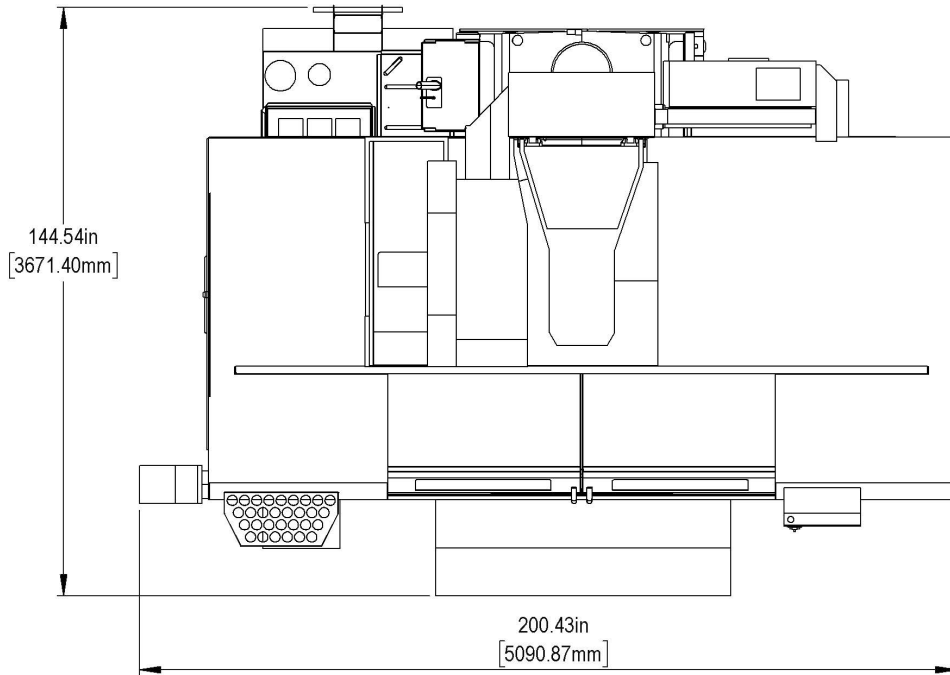

Shipping Dimensions

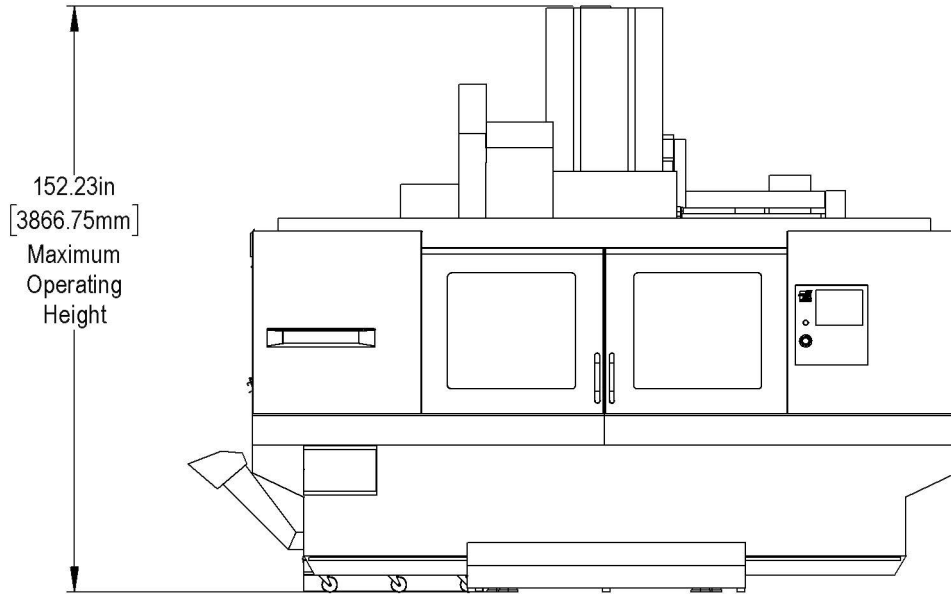
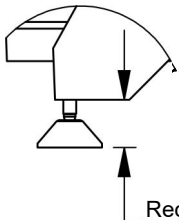
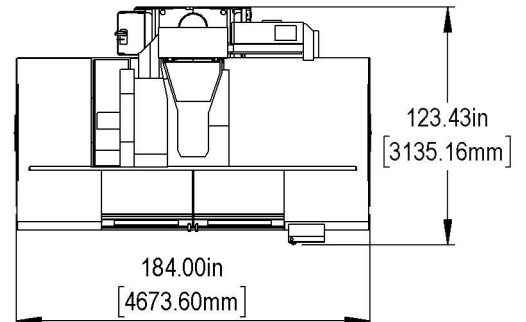
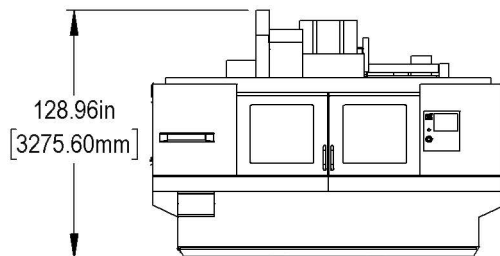

3.0in
[76.20]
Recommended

Air & Power

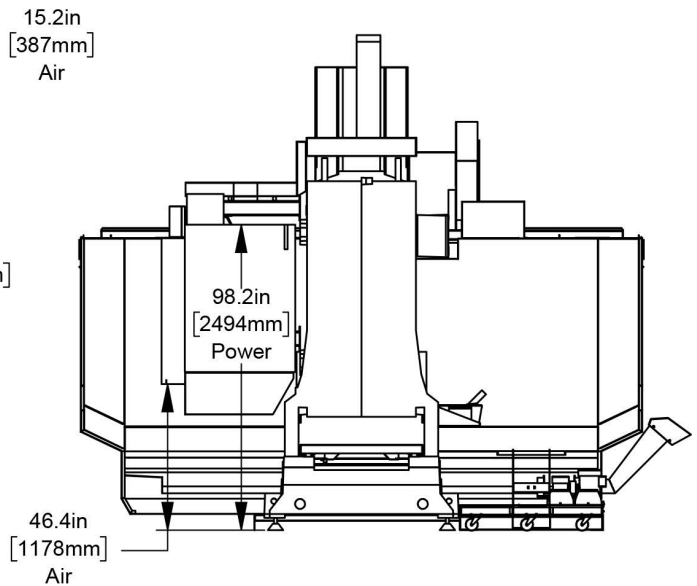
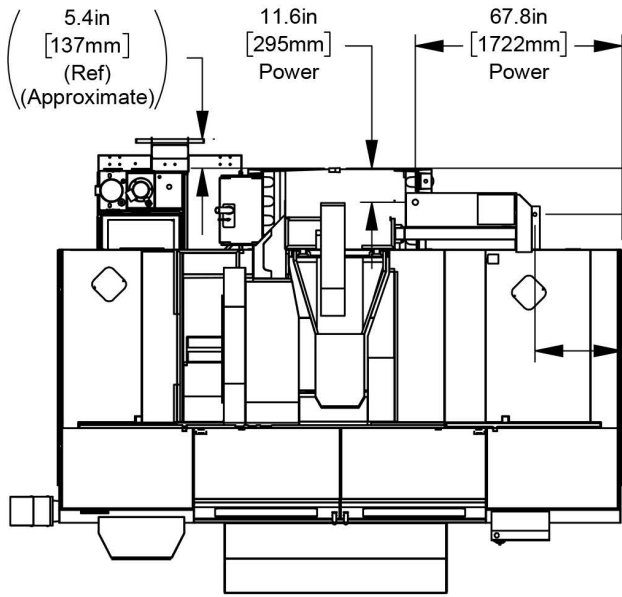

Anchor Detail

- Ø .625in [16mm]
- 2.0in [51mm]
- ▽ 2.25in [57mm]

Anchor Pattern

NOTE: For machines built after Sept. 2023

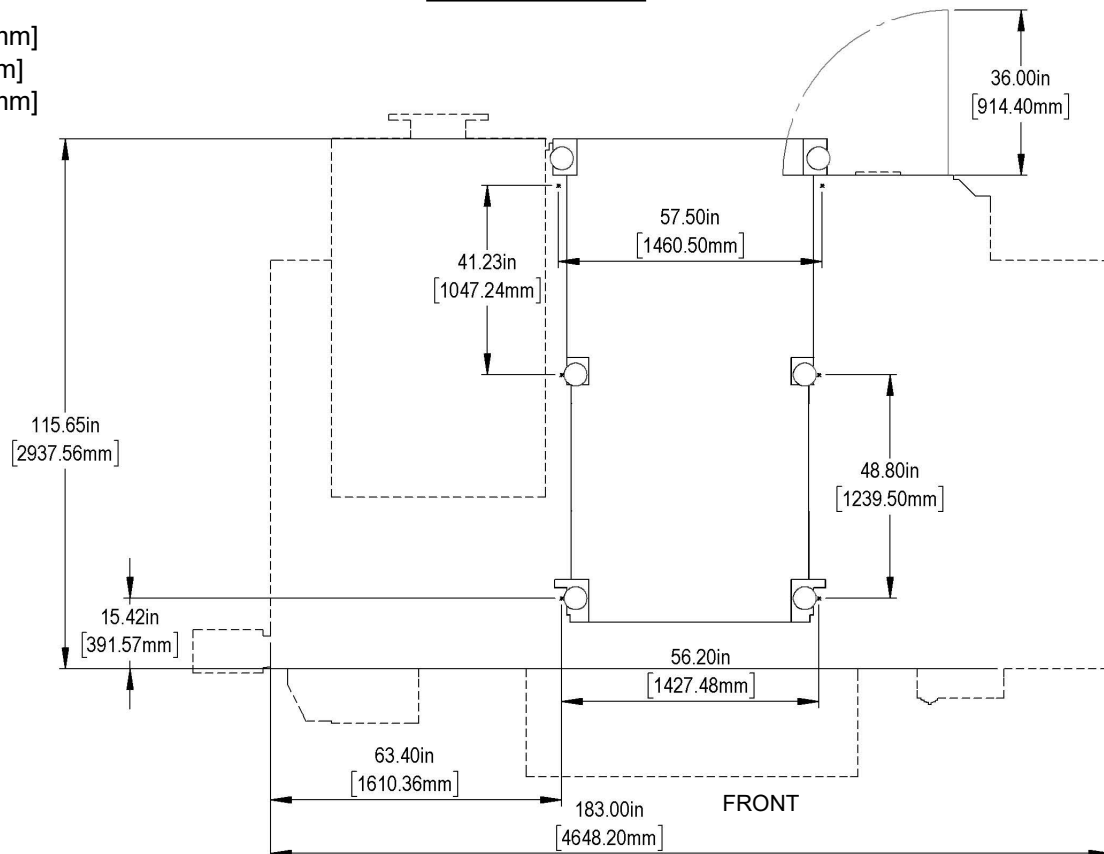

Height Breakdown

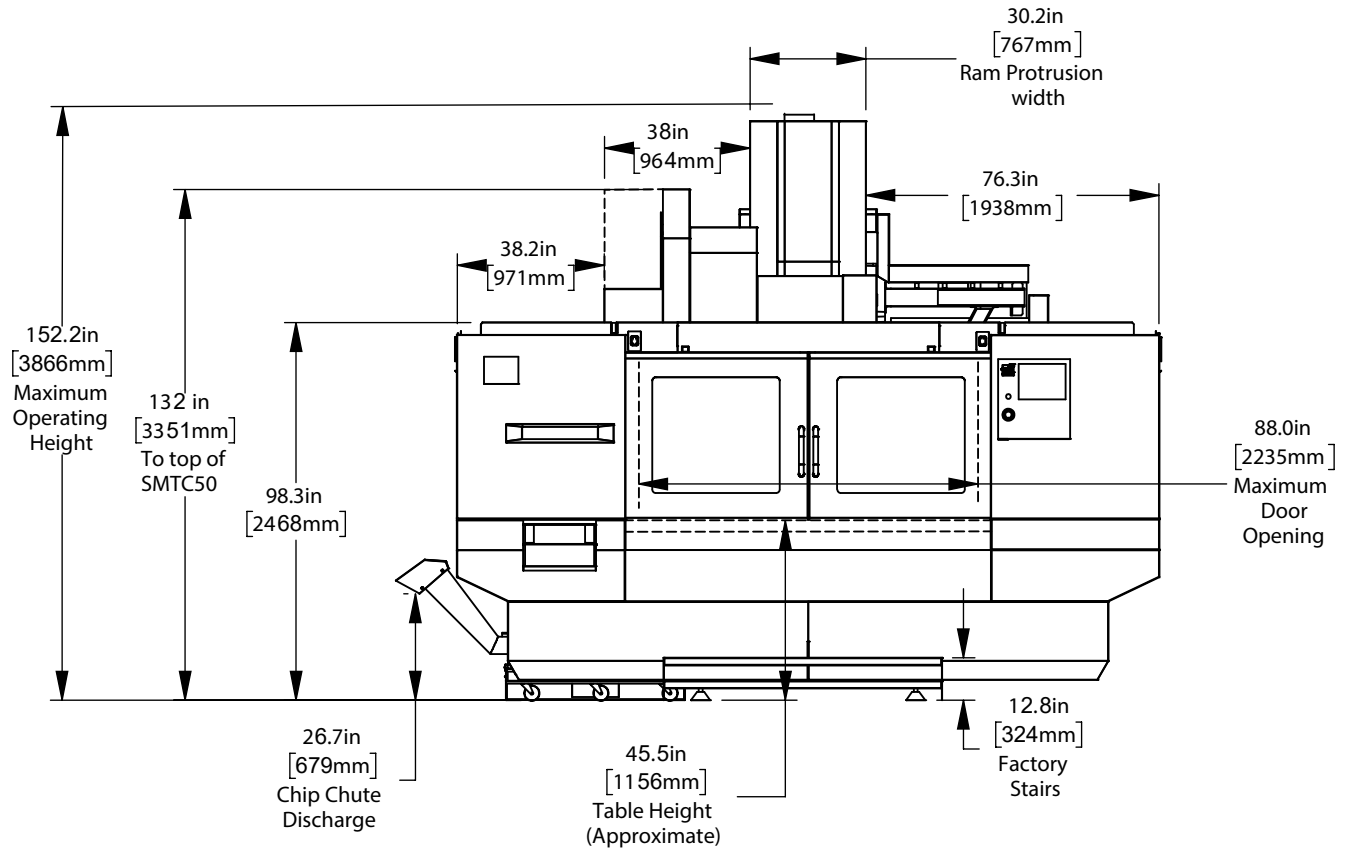

Width Breakdown

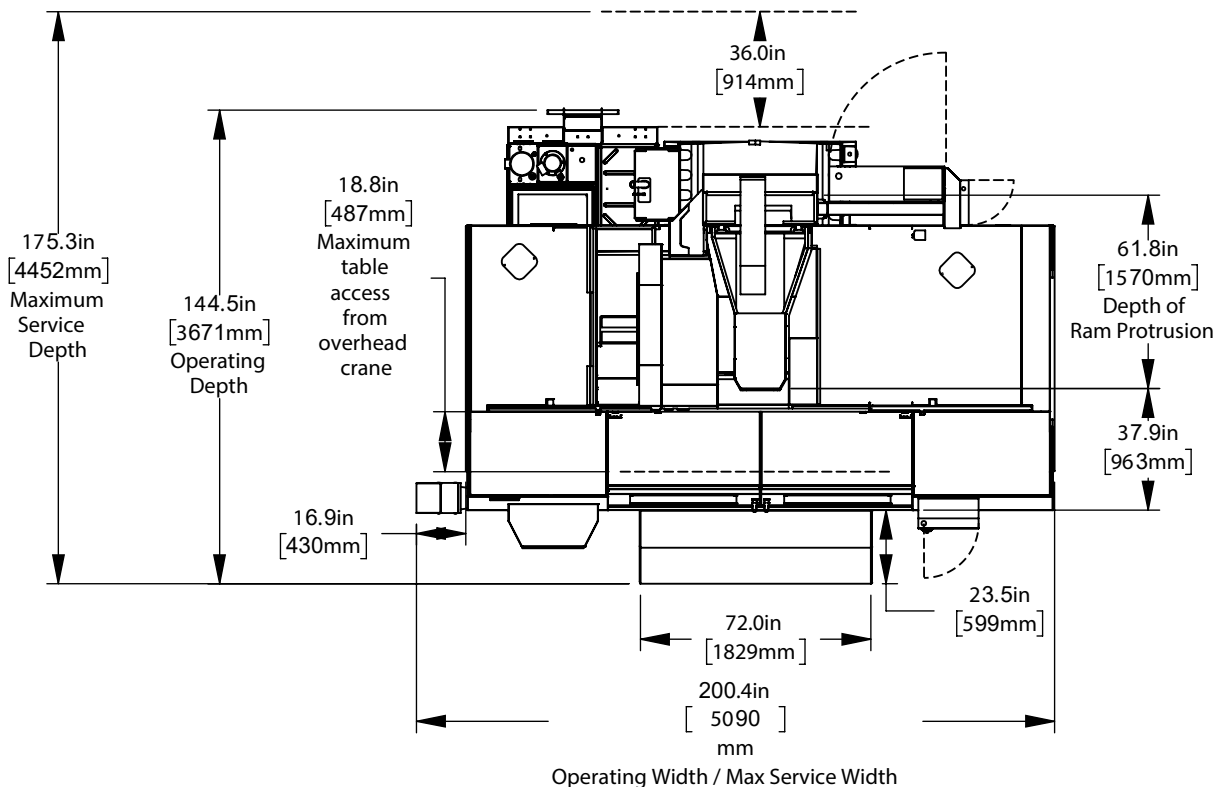

Maintain 3 feet [915mm] clearance to the nearest obstruction around all sides of machine perimeter for maintenance access

X & Y-Axis Travel at B0

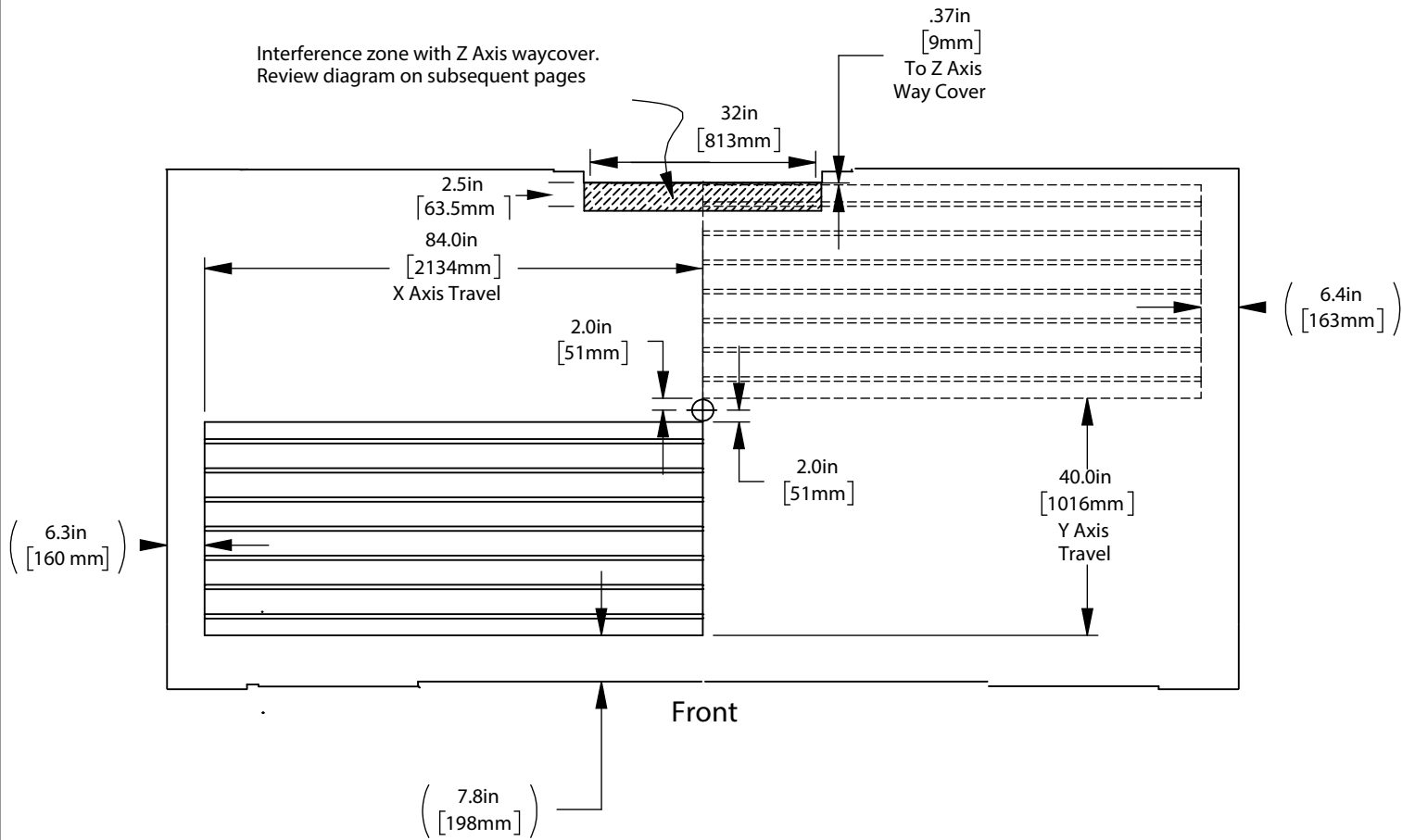

Top View STD Spindle Shown

B & C axis Travel

Side View

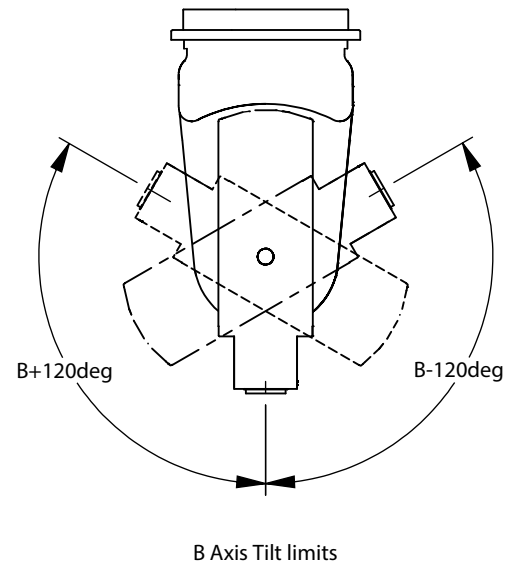
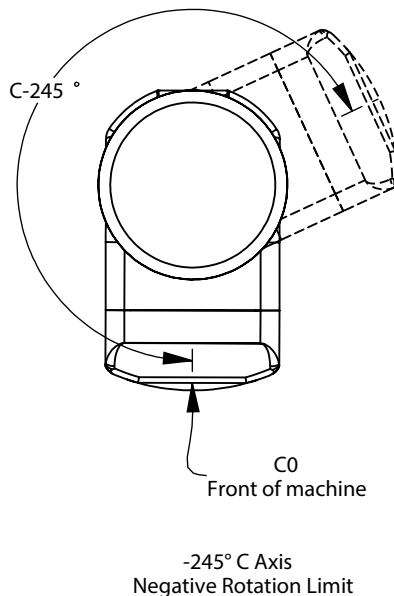
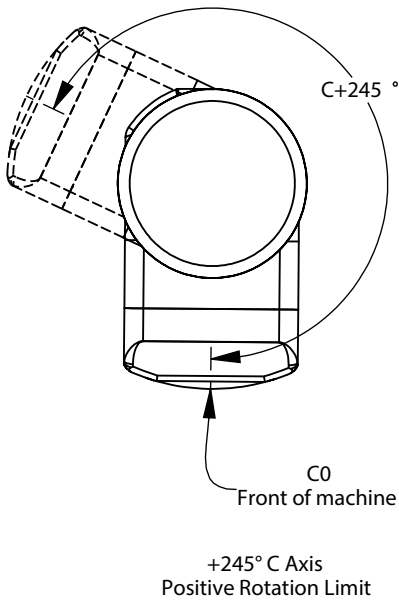

Isometric views of B & C Axis gimbal heads for visual reference

Single Support

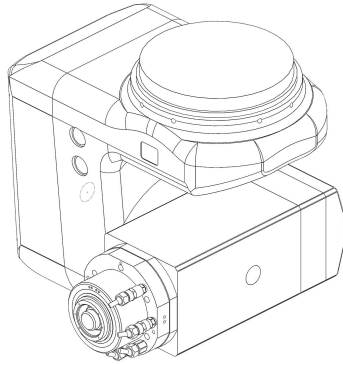

Dual Support

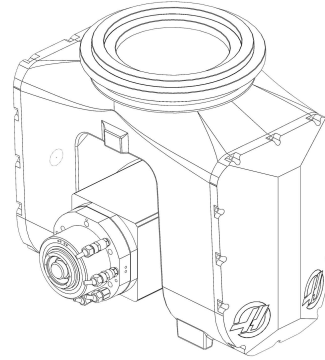

X&Y-Axis Clearance at B90 with C at 0, 90, -90, and 180
 (Measurements applicable to both Single and Dual Supports)

Notes -

The schematic above shows the B90° work envelope with no tool in the spindle.

Depending on the part size and how many faces require machining, the part may need to be centered or offset to one side of the table.

Subtract (the longest tool length required on each side of the part) + (clearance) from the travels shown below to determine the maximum size workpiece based on your tooling requirements

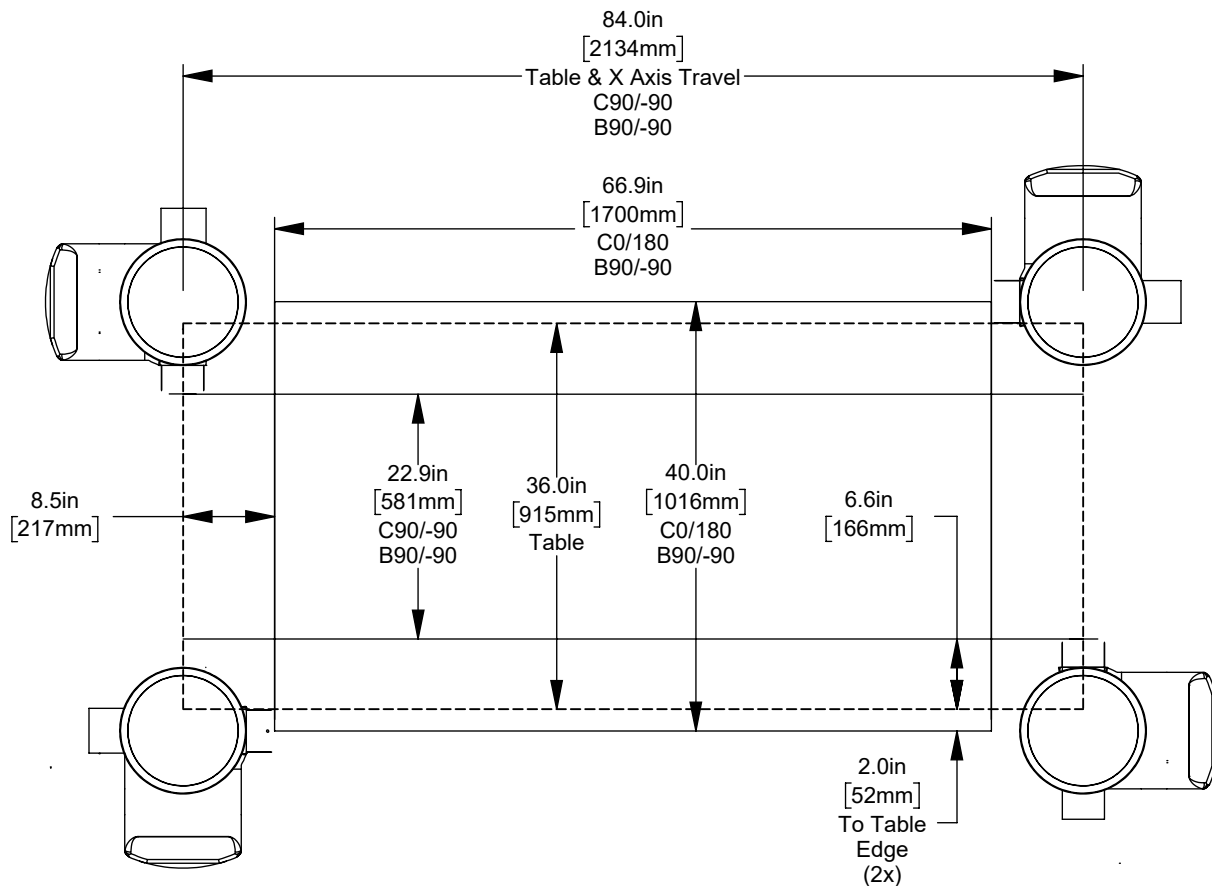

Table

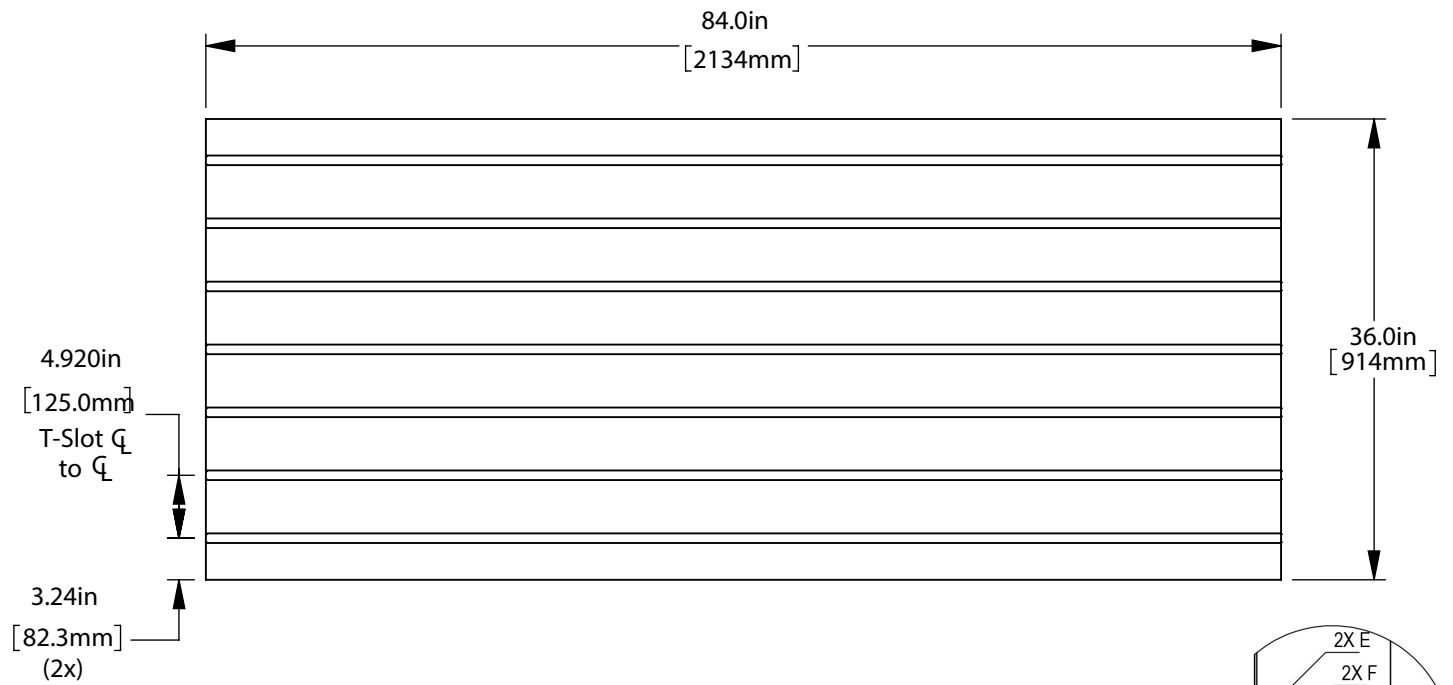

Slot Size	A	B	C	D	E	F
16mm	0.628±0.002	1.06±0.02	0.640±0.010	0.420±0.010	0.06x45°	0.020x45°

Tool Changer and Z Travel

(Measurements apply to both Standard and Dual Support except where noted)

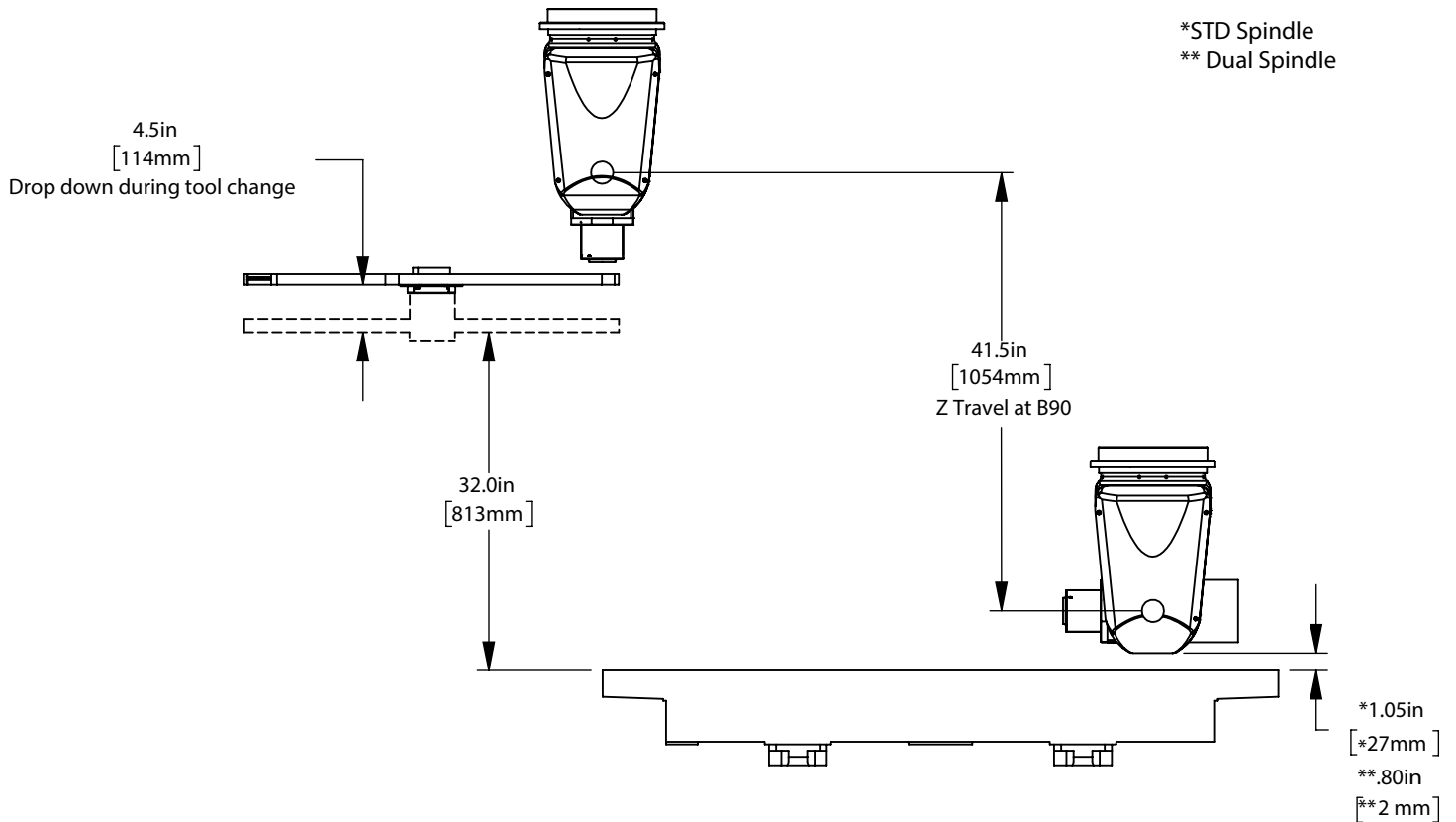

Interference and Interlock zones

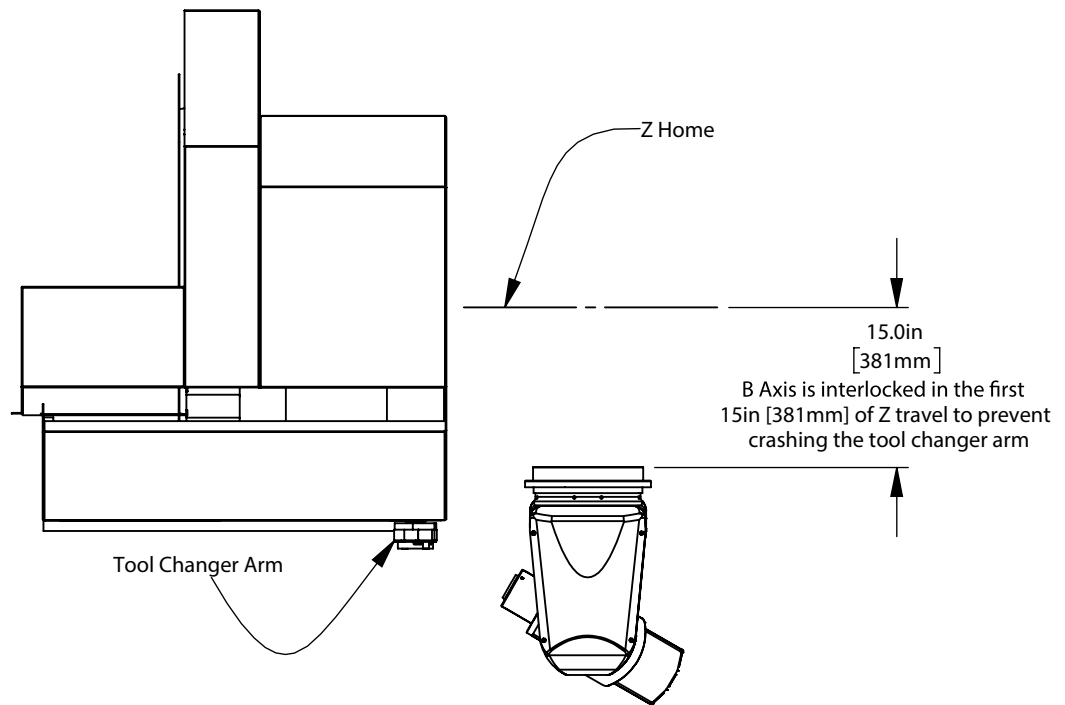

In addition to the tool changer interference zone, the machine has restricted zones between the gimbal head and fixed machine elements

When Setting 408 = 1 the interference zones account for the tool length based on its Z geometry in the offset table

When Setting 408 = 0 the tool length is not considered in the interference zones

Potential interference at maximum Z travel with Z axis casting

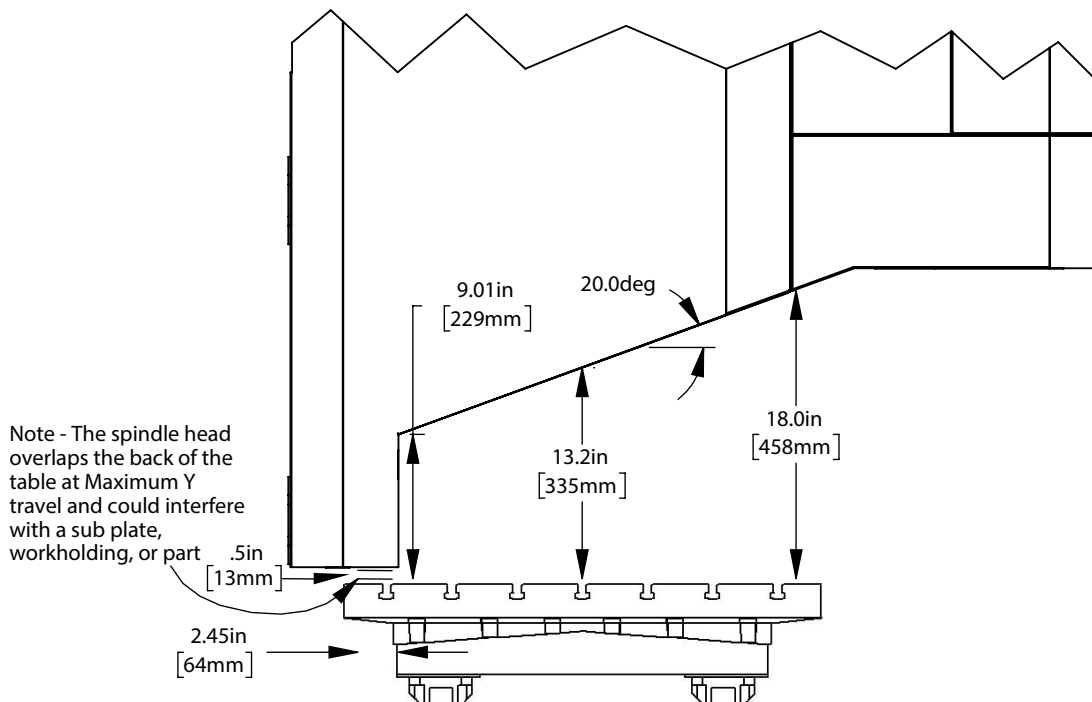

Minimum Z height to reach B120°
 (Measurements apply to both Standard and Dual Support)

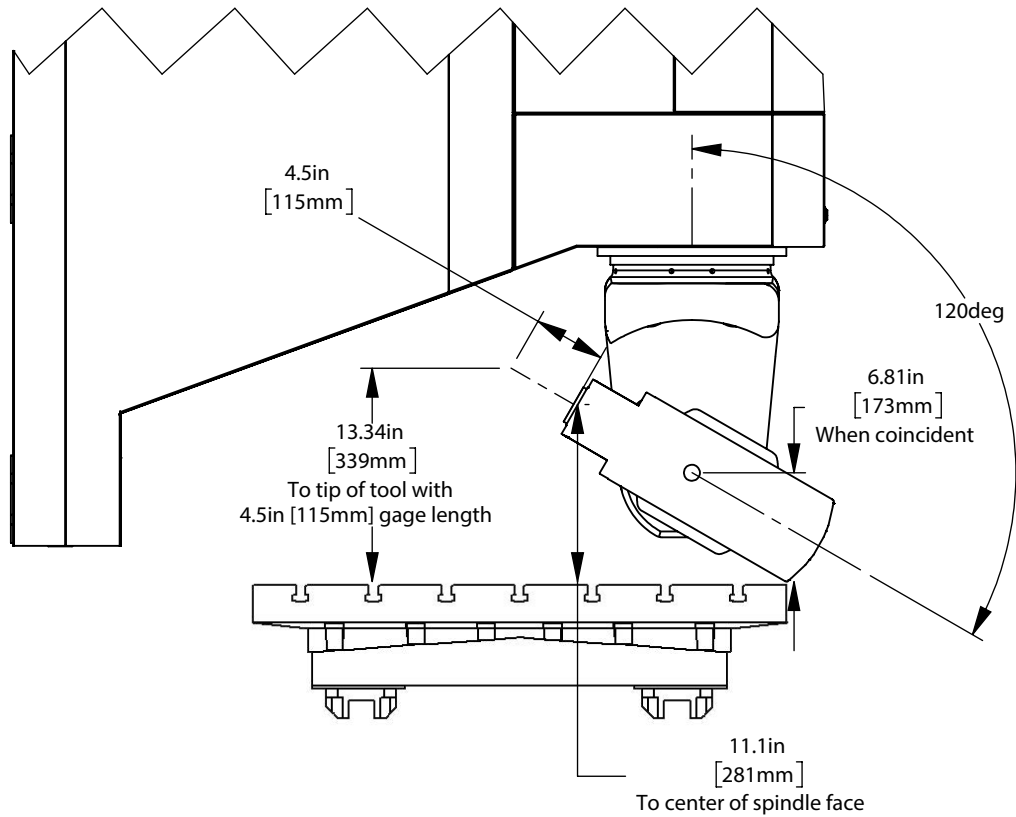

Single Support & Spindle Dimensions

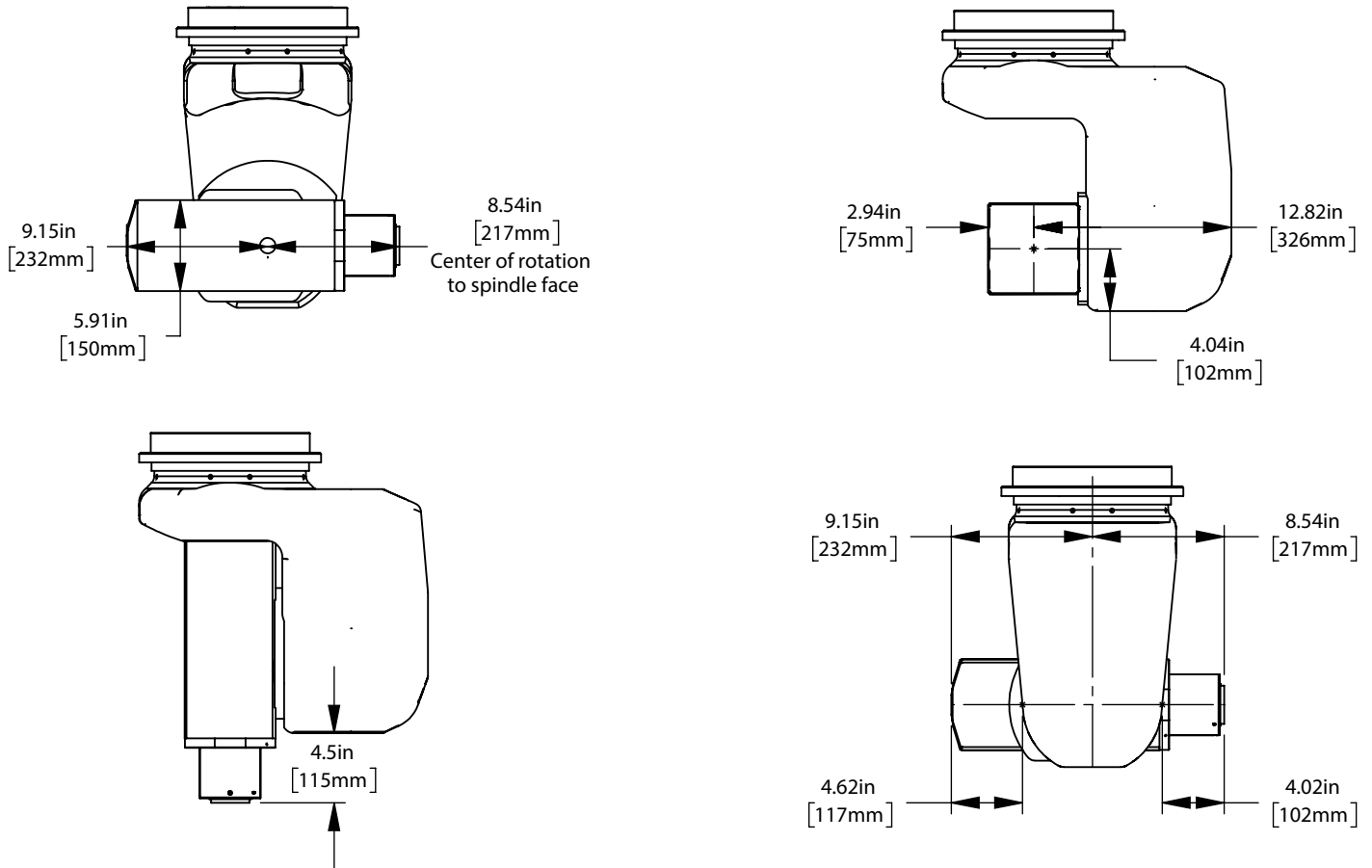

Dual Support & Spindle Dimensions

