

TOOLROOM MILL OPERATOR'S ADDENDUM

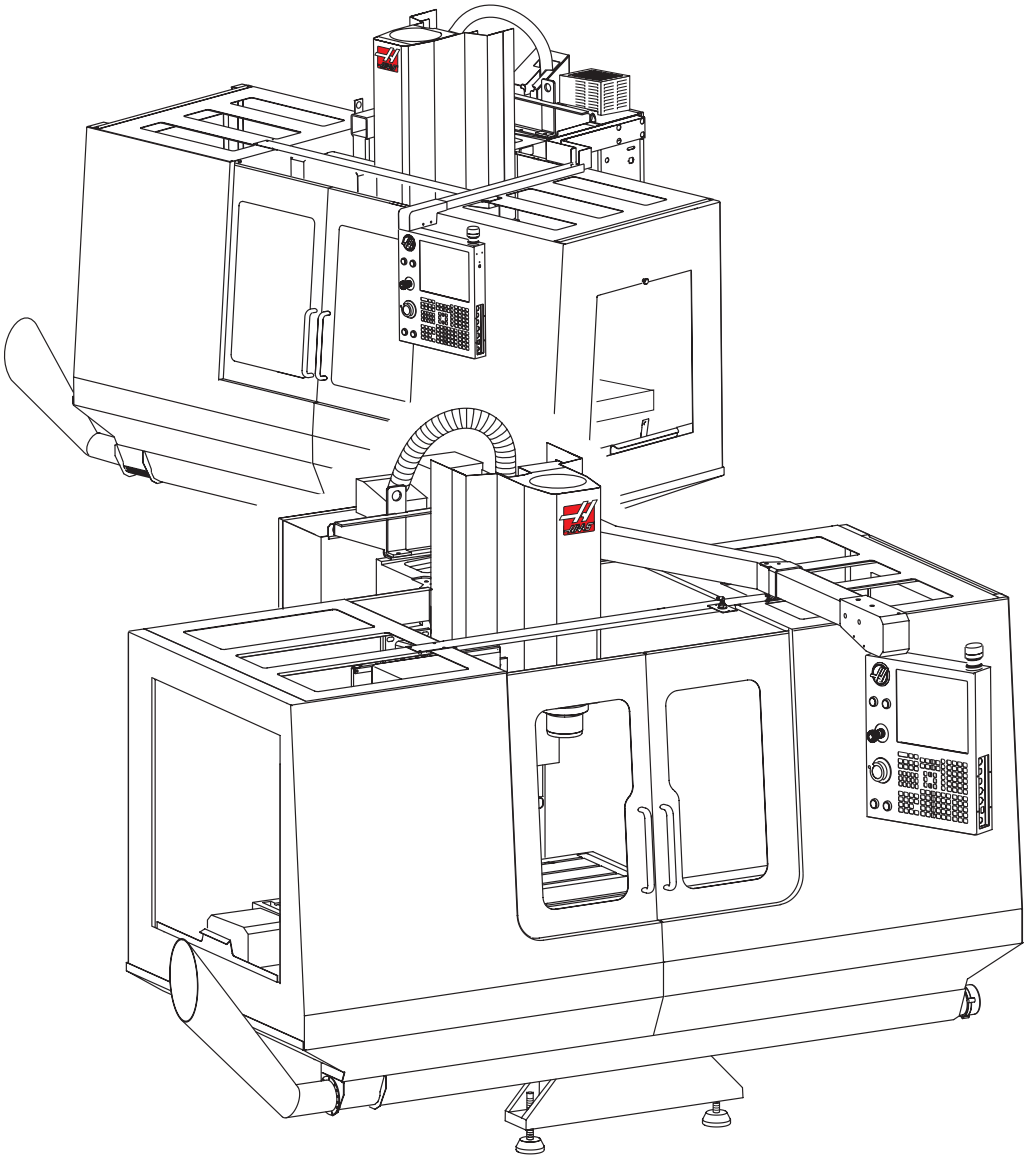



1. WARRANTY

All new HAAS Toolroom Mills are warranted exclusively by the Haas Automation's ("Manufacturer") limited warranty against defects in material and workmanship for a period of one (1) year from the date of purchase, which is the date that a machine is installed at the end user. See the Warranty section of the Mill Operator's Manual for further warranty information.

2. SAFETY

Read and Follow all safety warnings - Familiarize yourself with the Operator's Manual Safety chapter. Be aware of the other people around you in the shop; flying chips can seriously injure people, who may not be a safe distance away. Always wear safety glasses. Initial cuts/setups should be cut at a slower speed to reduce the possibility of tool or machine damage.

3. INSTALLATION

NOTE: These installation recommendations are to be used in conjunction with those in the Reference Manual. Material supplied here is given specifically for the Toolroom Mill.

ELECTRICITY REQUIREMENTS

IMPORTANT! REFER TO LOCAL CODE REQUIREMENTS BEFORE WIRING MACHINES.

- The power source must be grounded
- Frequency range is 47-66 Hz
- Line voltage that does not fluctuate more than +/-5%
- Voltage imbalance or no more than 2%
- Harmonic distortion is not to exceed 10% of the total RMS voltage

Voltage Requirements

Toolroom Mill	208 3PH / 240V 1PH ±10%
Power Supply	40 AMP
Haas Circuit Breaker	40 AMP
If service run from elec. panel is less than 100' use:	1PH - 8 GA WIRE/3PH - 10 GA WIRE
If service run from elec. panel is more than 100' use:	1PH - 6 GA WIRE/3PH - 8 GA WIRE

WARNING!

A separate earth ground wire of the same conductor size as input power is required to be connected to the machine chassis. This ground wire is required for operator safety and proper operation. This ground must be supplied from the main plant ground at the service entrance, and should be routed in the same conduit as input power to the machine. A local cold water pipe, or ground rod adjacent to the machine cannot be used for this purpose.



Machine input power must be grounded. The machine will not function properly on ungrounded power.

The maximum voltage leg-to-leg or leg-to-ground should not exceed 260 volts.

Connecting the Toolroom Mill to Power

The Toolroom Mill can be powered from either 3 Phase 208 Wye Power (Neutral Grounded) or Single Phase 240V. In either case, a separate ground wire of the same size as the main conductors must be provided in the power cable.

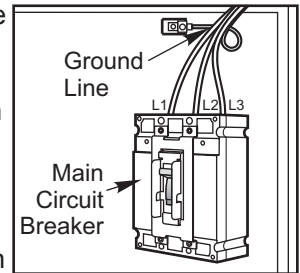

1. With the main circuit breaker in the OFF position (rotate the shaft that connects to the breaker counterclockwise), hook up the power lines to the terminals on top of the main circuit breaker. Connect the separate ground line to the ground bus to the left of the circuit breaker.

NOTE: For Single Phase operation, only terminals L1 and L3 of the circuit breaker are used. L2, the center connection, should be left open.

CAUTION! Make sure the main circuit breaker is in the OFF position BEFORE changing transformer connections.

2. T5 is a small transformer mounted on the power supply assembly next to the main circuit breaker. This transformer has two input connectors located about two-inches from the transformer that allow it to be connected to either 240V or 200V. If the incoming power is 220-250 VRMS, use the 240V connection. If the incoming power is 187-219 VRMS, use the 200V connection. Failure to use the correct input connector will result in either overheating of the main contactor or failure to reliably engage the main contactor.

3. The main power transformer is located at the bottom-right corner of the control cabinet. This transformer supplies Single Phase 115V power to the cabinet. It also has two different input connections located at terminal board TB2. If the incoming power is 187-215 VRMS, connect wire 74 to the 208V position (center). If the incoming power is 216-250 VRMS, connect wire 74 to the 240V position (left).

4. Turn the main circuit breaker to the ON position (rotate the shaft clockwise). Apply power to the control by pressing the Power-On switch on the control panel. Verify that the Fault Indicator on the 320V Power Supply (located above the main power transformer) displays the number "1", which signifies a normal power-up sequence. Next, verify the DC bus voltage on pins 6 & 7 with a voltmeter. The voltage should read approximately 335VDC if powered from 240V, or closer to 290V if powered from 208V. If the voltage is not at least 260VDC, call the Service Department.

5. Turn the main circuit breaker OFF by rotating its shaft counterclockwise. Close the door, lock the latches, and turn the power back on.



LEVELING

The Toolroom Mill is leveled in the same manner as a VF-Series machine.

NOTE: Before any axis movement takes place, remove the shipping bracket from the spindle and table, and remove any wooden crating from the top of the spindle head. Severe damage will occur if machine operation is attempted with the shipping bracket in place.

4. MACHINING PRACTICES

This section is a general overview of basic machining practices. It is intended to familiarize you with basic setup and operation techniques. Good machining practices extend tool life and in the end can save money.

Insert Selection

Although inserts are expendable it does not mean that an operator should be careless in the setup. The following are the most common insert materials used. Each has a description of its characteristics and common usage.

High Speed Steel

- Allow for higher rake angles
- Resists chipping
- Resists softening due to high temperatures.

Carbide

- Good resistance to high temperatures
- Lower edge strength than high-speed steel
- Different composition of carbide can result in different finishes

Ceramic

- Yields good finish
- Requires negative rake angle due to low strength
- Requires very rigid setup
- Requires high horsepower

Diamond

- Four times harder than carbide
- Can retain their cutting edge for almost the length of the tool life
- Excellent stability for close tolerance work
- Excellent finish quality

NOTE: Remember to use the highest quality tooling designed for CNC machines to achieve the best cutting condition possible.



Tool Wear

Tool life is dependant upon the following criteria:

- Cutting feedrate
- Tool and workpiece material
- How much material is being removed
- Proper workholding device
- Use of coolants
- Use of correct SFPM (RPM) for tool and material

Tools are subject to gradual wear from the following elements:

Abrasion (Friction and rubbing removes material from the cutter.)

Caused by:

- Friction on the outside of the cutter as it passes through the material.

Adhesion High pressure/temperatures weld small chip particles to cutter.

Caused by:

- Low cutting speed
- High feed rate
- Negative cutting geometry
- 'Sticky' materials such as some stainless steels and pure aluminum
- Lack of coolants

Chipping The cutting edge is broken off instead of being worn away.

Caused by:

- Excessive feed rate
- Interrupted cut
- Insert geometry too weak
- Chatter

Cratering Characterized by a smooth depression on the face of the insert.

Caused by:

- Excessive cutting speed
- Ineffective use of coolant
- Friction
- Normal wear

Oxidation

- Occurs during very high cutting temperatures
- Weakens tool tips

Chemical wear: Cutter/workpiece reaction begins to corrode insert (corrosion)

Coolant

There are a number of reasons why coolant is used in the machining process; it is used to dissipate heat generated during machining, reduces cutter friction, and promotes chip clearance. It also allows for high speed machining and increases tool life.

Coolant is not recommended when machining cast iron or steel, or when using carbide cutters. Carbide cutters can withstand high temperatures but not thermal shock of coolant.



Cutting fluids are best suited for soft materials such as aluminum alloys and brass.

A good flow of cutting fluid should be directed to both sides of cutter whenever possible.

These are the most common types of cutting fluids:

Emulsion (water combined with mineral oils and additives)

- Used for light to moderate machining

Cutting oils (grease or solid additives)

- Limited to slow speed and low feed conditions due to flammability
- Expensive to use

Chemical or semi-chemical fluids (synthetic)

- Contain no petroleum oils
- Used for more difficult machining/grinding operations

Workpiece

The more you know about the workpiece, the better you can control the machining process. As a general rule ask these questions:

- What is the type of metal (alloy or steel)
- Has the part undergone any special process, i.e. case hardening, treated with additives or heat treated, etc.?

Feed Rate

Feed rate is determined by the required surface finish and cutting force. Expressed in:

- Inches or millimeters per minute
- Inches or millimeters per revolution
- Inches per tooth

Minimum chip thickness (chip load) is determined by the cutting force.

Maximum chip thickness (chip load) is determined by machine power and tool design.

Spindle Speed

RPM = speed at which the tooling is turning. The mill can be commanded in either clockwise (CW) or counterclockwise (CCW) direction. The type of application or style of tool will usually dictate the spindle direction.

Depth of Cut

The distance the cutter penetrates the workpiece, also referred to as chip load.

This is determined by the following factors:

- Rigidity of the cutter and machine
- Machine capabilities
- Spindle horsepower



Machine Productivity

Use the load meter as an indicator of how the machine is cutting. Speeds and feeds should be adjusted after the initial cut. The initial cut will give an instant read-out of the performance of the machine. If adjustments are necessary, they should be made in 10% increments. Pay close attention to:

- Chip formation and color
- Chip load
- Monitor part and fixture during the cut
- Listen for any unusual noises

Surface Finish

A good finish depends on a number of variables. The following are a number of items to check to achieve a good finish:

- Good finish results in slower feeds and higher speeds
- Face milling produces the best finish
- Increasing the number of cutters (inserts) allow for a better finish
- Cuts should always be in the same direction
- Lighter depth of cuts will produce a better finish
- Coolants use can also affect part finish

Accuracy

Machine accuracy can be affected by a number of variables, such as:

- Is the machine properly warmed up?
- Holes should be center drilled first
- Check the condition of the tooling

Cutting Tool Descriptions

Drill Used to create a cylindrical hole in a work piece. Drilled holes can be “through holes” or “blind holes”. A “blind hole” is not cut entirely through a work piece.

Center drill A small drill with a pilot point. It is used to create a small hole with tapered walls. When a hole’s location must be held to a close tolerance, use a center drill first and then use a regular drill to finish the hole. The tapered walls of the center-drilled hole will keep the regular drill straight when it begins to drill into the work piece.

Reamer Designed to remove a small amount of material from a drilled hole. The reamer can hold very close tolerance on the diameter of a hole, and give a superior surface finish. The hole **must be** drilled first, leaving .005 to .015 of an inch stock on the walls of the hole for the reamer to remove.

Tap Used to create screw threads inside of a drilled hole. NOTE: Care must be taken when using a milling machine to perform a tapping operation. For example, the spindle speed and feed must be synchronized.

End Mill Shaped similar to a drill, but with a flat bottom (end). It is used primarily to cut with the side of the tool, to contour the shape of a work piece.



Bull End Mill A bull end mill is the same as a regular end mill except that there is a radius on the corner where the side meets the bottom. This radius can be up to $\frac{1}{2}$ of the tool's diameter.

Ball End Mill A ball end mill is a bull end mill where the corner radius is exactly $\frac{1}{2}$ the tool's diameter. This gives the tool a spherical shape at the end. It can be used to cut with the side of the tool like an end mill.

Work Holding

Work holding is one of the most important elements of setting up any machine tool. Work holding is the method of clamping the work piece to the machine. The work piece must always be held securely before any cutting can take place. Three basic types of work holding are used in milling operations. They are: a mill vise, clamps, and a chuck. The type used is dependant upon how large the cutting pressure on the workpiece is going to be. The maximum holding pressure of a manual clamp is determined by the strength of the operator. Large work holding forces require a pneumatic or hydraulic fixture.

Fixtures should be kept close to the center of the table in order to maintain a rigid setup. If placed at the ends of the table, harmonic vibrations could occur.

Before placing any type of work holding on your machine table, great care must be taken to be sure that the table is clean and free of chips and other debris. The work holding equipment also must be clean, free of debris, and have no burrs or dings that may cause instability or damage the table. If you plan to leave your work holding on the table for any length of time, a light coat of rust-preventative oil will help keep your table and work holding free of rust and corrosion.

The most common method of holding a work piece for machining is a mill vise. The vise is attached to the mill table using tee nuts and bolts. The tee nuts slide into the tee slots in the mill table and the bolts clamp the vise in position. Two bolts on either side of the vise hold it in place. For precision work, the vise must be set so that the clamping surfaces are parallel to the X or Y-axis of machine travel. This is done using an indicator.

To indicate a vise parallel to a machine axis, you will need an indicator and a magnetic base to hold it. Place the magnetic base anywhere on the bottom of the Z-axis head or the spindle housing. Jog the machine axis to bring the indicator tip to the clamping surface you want to indicate. Set the tip of the indicator so it begins to register on the indicator dial. Use the jog handle to move the axis you want the clamping surface to be parallel to and determine which direction the vise needs to be moved to become parallel. If the right side of the vise needs to be moved toward the back of the machine, tighten the bolt on the left side of the vise to be snug and leave the bolt on the right side of the vise loose. With a dead-blow Mallet, tap the vise until the clamping surface is parallel with the machine axis. Check the result by jogging the axis back and fourth. You may need to do this several times. When the vise is parallel, tighten all the bolts and check the set-up again. Adjust if necessary.



Another common type of work holding on a milling machine is clamps. If you have an odd shaped work piece or a large one that does not fit into a mill vise, you can clamp it directly to the mill table or fixture plate using clamps. Clamps are usually a bar type with an oval slot cut through the bar for a bolt and a tapped hole in the bar for a jackscrew. The jackscrew is set to be slightly longer than your work piece is tall. A small shim made of soft material .05" minimum thickness should be placed between the jackscrew and the machine table to prevent the screw from damaging the table when the clamp is tightened.

Set the clamp on top of the work piece and the jackscrew and shim on the table. Place a bolt through the slot in the clamp and screw it into a tee nut in the table's tee slot and tighten the bolt to increase the clamping pressure. A series of clamps around your part should hold it in place during machining.

If you need to machine completely through the part, you will need to get the work piece off of the table. In this case, place blocks between your work piece and the table at the same locations where your clamps are. The blocks need to be directly under the clamps and all the blocks need to be the same height.

Another method of getting your work piece up off the table is to make a fixture plate. The fixture plate can be bolted to the machine table using tee nuts and bolts. Drill and tap holes where the clamps need to be. Clamp your part to the fixture plate as described above.

A third method of work holding is for round, cylindrical work pieces. A chuck with movable clamping jaws can be mounted to the machine table. The chuck works like the small chucks on a drill press or a drill motor. A chuck key is used to turn a screw in the side of the chuck, which moves all the clamping jaws simultaneously to clamp on a round work piece.

For information on other types of work holding or more information on the types discussed here, contact your local distributor of industrial supplies.



5. OPERATION

POWER UP

The mill is powered up by pressing the “Power On” button. Press “Power Up / Restart” and the mill will automatically find home.

INTRODUCTION

The Haas Toolroom Mills are supplied with the Intuitive Programming System (IPS). This is displayed once the mill is powered up and homed. This screen shows the X, Y and Z position of the mill as well as the spindle speed. This programming system helps the operator set up operations such as setting tool and work offsets, drilling and tapping cycles, circular and rectangular pocket milling, without knowledge of G-code programming.

The control will prompt for basic machining information tool type, coordinates, feedrate, spindle speed, depth of cut, etc. Once all information is entered, the Toolroom mill performs the desired operation.

IPS Navigation

To navigate through the menus of the Intuitive Programming System, use the left and right arrow keys. To select the menu press Write/Enter. Some menus have sub-menus, which again use the left and right arrow keys and Enter to select a sub-menu. Use the arrow keys to navigate through the variables. Key in a variable using the number pad and press Write/Enter. To exit the menu press Cancel. Each of the variables has help text, which is displayed once the variable is selected.

To change to full CNC mode press any of the Display keys, except Offset. A complete list of G-Codes is described in the Operator’s manual and includes examples to demonstrate the use of the G-codes. Press “Handle Jog” to return to the Toolroom Mill menus.

A program entered through Toolroom Mill screens is also accessible in MDI (full CNC).

IPS RECORDER

The IPS recorder provides a simple method to place G-code generated by IPS into new or existing programs.



OPERATION

1. To access IPS, press MDI/DNC, then PROGRAM/CONVRS.
2. When the recorder is available, a message appears in red in the lower right corner:

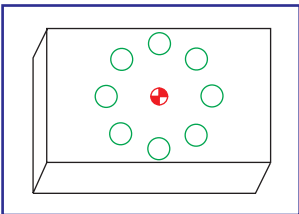
MANUAL	SETUP	FACE	DRILL	POCKET MILLING	ENGRAVING	VOC
CENTER DRILL 0	DRILL TOOL 0	TAP TOOL 0				
CENTER DEPTH 0.0000 in	DRILL DEPTH 0.0000 in	TAP DEPTH 0.0000 in				
CENTER PECK 0.0000 in	DRILL PECK 0.0000 in					
WRK ZERO OFST 54	R PLANE 0.2000 in	NUM OF HOLES 0	<p>Press < CYCLE START > to run in MDI or < F4 > to record output to a program.</p>			
X CENTER PT 0.0000 in	DIAMETER 0.0000 in	CENTER HOLE 0				
Y CENTER PT 0.0000 in	ANGLE 0.000 deg					
BOLT CIRCLE	BOLT LINE	SINGLE HOLE	MULTIPLE HOLES			

3. Press F4 to access the IPS recorder menu. Choose menu option 1 or 2 to continue, or option 3 to cancel and return to IPS. F4 can also be used to return to IPS from any point within IPS recorder.

0.0000 in	
IPS RECORDER	
F4 - CANCEL	
<p>1.) Select / Create Program 2.) Output to current program 3.) Cancel</p>	
0.0000 in	U

IPS Recorder Menu

Menu Option 1: Select / Create Program

Select this menu option to choose an existing program in memory or to create a new program into which the G-code will be inserted.

1. To create a new program, input the letter 'O' followed by the desired program number and press the WRITE key. The new program is created, selected, and displayed. Press the WRITE key once more to insert the IPS G-code into the new program.



2. To select an existing program, enter an existing program number using the O format (Oxxxxx), then press the WRITE key to select and open the program. To choose from a list of existing programs, press the WRITE key without input. Use the cursor arrow keys to choose a program and press WRITE to open it.

MANUAL **SETUP** **FACE** **DRILL** **POCKET MILLING** **ENGRAVING** **VQC**

Center Drill

Center Depth

Center Peck

WRK ZERO OFST

X CENTER PT

Y CENTER PT **ANGLE**

BOLT CIRCLE **BOLT LINE** **SINGLE HOLE** **MULTIPLE HOLES**

Select / Create Program **F4 - CANCEL**

000000 (PROGRAM A)
000001 (PROGRAM B)
000002 (PROGRAM C)
000003 (PROGRAM D)
000004 (PROGRAM E)
000005 (PROGRAM F)
*000006 (PROGRAM G)

Choose a program by using the cursor keys and press WRITE to select.
or
Enter a 'O' followed by a new program number and press WRITE to create.

CYCLE START >
MDI or <F4>
output to a

3. Using the arrow keys, move the cursor to the desired insertion point for the new code. Press WRITE to insert the code.

Menu Option 2: Output to Current Program

1. Select this option to open the currently selected program in memory.
2. Use the arrow keys to move the cursor to the desired insertion point for the new code. Press WRITE to insert the code.



6. MAINTENANCE

The linear guide trucks are filled with grease at the factory. Under infrequent or light duty use the factory lube is sufficient for several months. It is important that the axes are cycled to their full travel daily to coat the linear guides with grease in order to protect the surfaces.

More severe use, such as cutting absorbent materials (such as wood), or excessive coolant use (which washes the linear guides), will require weekly greasing - Two strokes of the supplied grease gun is sufficient. Do not over grease, as the excessive pressure of over-greasing or using a pneumatic or an electrical grease gun is harmful to the seals. It is not necessary to see grease squeezing out of the seals.

Grease type: General-purpose lithium

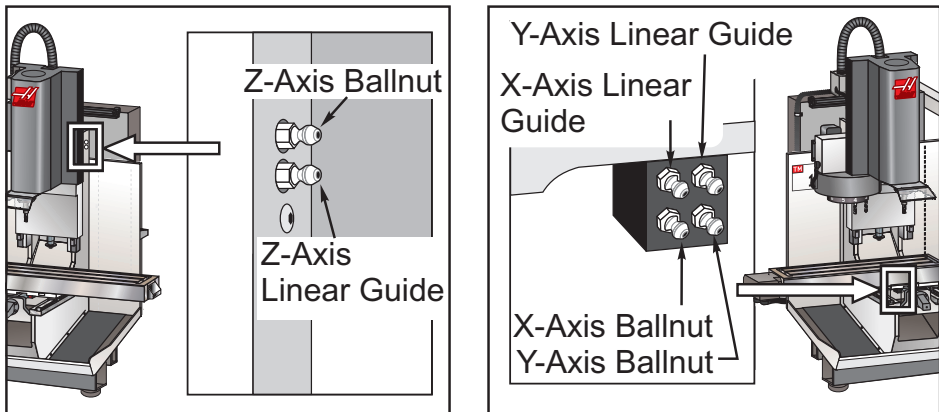

Grease fitting locations. Mill pictured without enclosure for clarity

Also check the Maintenance chapter of the Operator's manual for additional maintenance issues.

Note that the Toolroom Mill does not have a gearbox or a TSC system; disregard these maintenance sections.