

Sheet Router (SR-100) Operator's Addendum

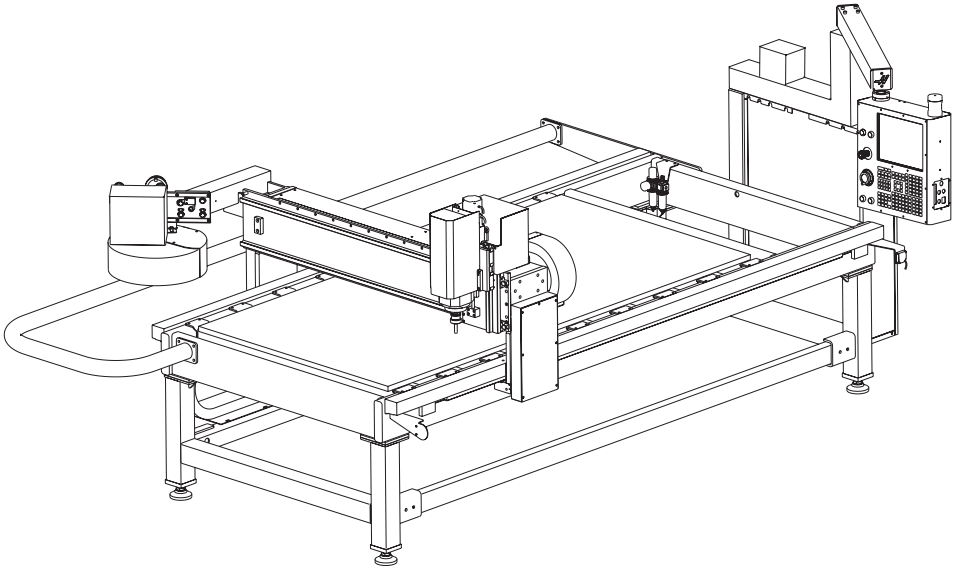



SAFETY

Read and Follow all safety warnings - Familiarize yourself with the safety section of the Operator's Manual. Be aware of the other people around you in the shop; flying chips can seriously injure people who may not be a safe distance away. Always wear safety glasses. Initial cuts/setups should be cut at a slower speed to reduce the possibility of tool or machine damage. As with any open frame mill, chip screens are highly recommended.

This machine must be operated only by trained and qualified personnel in order to insure a safe environment. The following precautions are provided to help protect the machine operator against accidents. Every operator of this machine must read this section and understand the requirements necessary to operate this equipment in a safe manner. These Sheet Router safety guidelines are only available in English; it is the customer's responsibility to make non-English speaking personnel aware of these guidelines.

Modifications to this machine or these procedures will not ensure safe operation. The machine power must be turned OFF prior to the removal of any panels for the purpose of service or maintenance access.

Any additional guards, or safety devices deemed necessary, are the sole responsibility of the machine operator.

This machine is designed to be operated as an "Open Architecture" machine. "Open Architecture" refers to a machine that does not include every guard necessary to keep the operator out of the machining envelope. To avoid accidents, the operator must stay within a designated work area during machining operations. During operation, all non-essential personnel must remain clear of the machine.

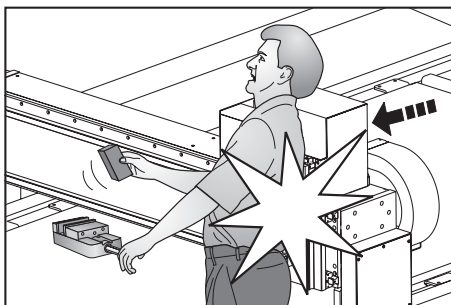

Some machine locations, especially on open frame mills, may have unguarded areas. The installation of the machine should be such that it will limit the access to the machine.

The machine may start unexpectedly and injure personnel or damage property.

This machine moves quickly. It is the shop owner's responsibility to provide measures to safeguard the worker.

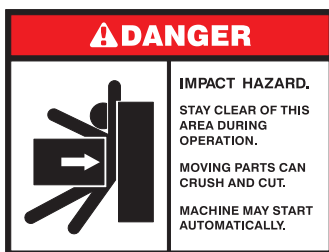

A photoelectric beam is used to stop the machine should personnel or equipment enter the protected area. This system will also stop the machine should a large quantity of machining chips pass through the beam. If this happens, change the set-up or machining process to avoid this condition.

1. INSTALLATION

Air Requirements

The Sheet Router requires 4 scfm (standard cubic feet/minute) of air at 100 psi (113 L/min @ 6.9 bar).

Electrical Requirements

IMPORTANT! REFER TO LOCAL CODE REQUIREMENTS BEFORE WIRING MACHINES.

- The power source must be grounded
- Frequency range is 47-66 Hz
- Line voltage that does not fluctuate more than +/-5%
- Voltage imbalance of no more than 2%
- Harmonic distortion is not to exceed 10% of the total RMS voltage

Sheet Router

Voltage Requirement 208-230V AC 3-ph or, 240V AC 1-ph +/- 10%

Power Required 8.3 kVA

Power Supply 40 AMP

Haas Circuit Breaker 40 AMP

Use 8 Gauge wire (larger gauge if service run is in excess of 100').

WARNING!

A separate earth ground wire of the same conductor size as the input power may be connected to the chassis of the machine. This ground wire promotes operator safety and proper operation. This ground must be supplied from the main plant ground at the service entrance, and should be routed in the same conduit as the input power to the machine. A local cold water pipe, or ground rod adjacent to the machine cannot be used for this purpose.

Input power to the machine must be reference grounded. The machine will not function properly on ungrounded power. The maximum voltage leg-to-leg or leg-to-ground should not exceed 260 volts.



Power Connection

The SR-100 can operate on either 3-phase 208VAC or single-phase 240VAC. Connect the incoming power lines as shown.

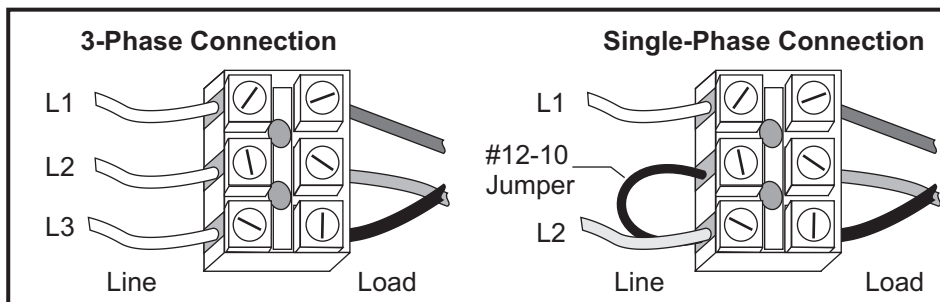

Spindle

Taper Size

ISO 30, Use HSD USA Inc. pull stud
P/N 0804H0009 only.

Max/Min Speed

24,000 rpm/500 rpm

Drive System

Integral Motor

Spindle Motor Rating (cont.)

5 hp (3.8 kW) @ 12,000 rpm

Spindle Torque (cont.)

2.21 ft-lb (3.0 Nm) @ 12,000 rpm

ISO 30 Toolholders

- Toolholder geometry must comply with DIN 69871 standard.
- Use only ISO 30 toolholders of AT3 precision rating.
- Do not use toolholders that have lumps, hollows or other shapes that could affect dynamic balancing.
- Dynamic balancing of tools must be better than $G=2.5$ (ISO 1940 standard) at the spindle's maximum rated speed. This includes the entire tool (tool holder, pull stud, collet, tool).
- Balancing must always be done with the tool assembled (pull stud, toolholder, tool).
- Use only pull studs provided by HSD (code 0804H0009) to secure the toolholder into the spindle.

To install the pull stud in the ISO 30 toolholder:

1. Thoroughly clean the mating surfaces of the pull stud and its seat.

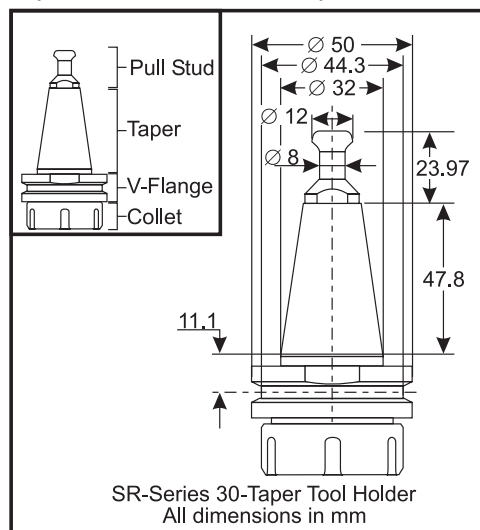



2. Apply a permanent thread locking compound to the pull stud.
3. Tighten the pull stud into the toolholder to a torque of 62 Nm (46 ft-lbs).
4. Follow the instructions provided with the thread locking compound regarding necessary cure time before the toolholder is used.

MOVING THE SHEET ROUTER

Use a forklift with at least a 4,000 lb rating. Use the illustration as a guide for proper fork truck lifting.

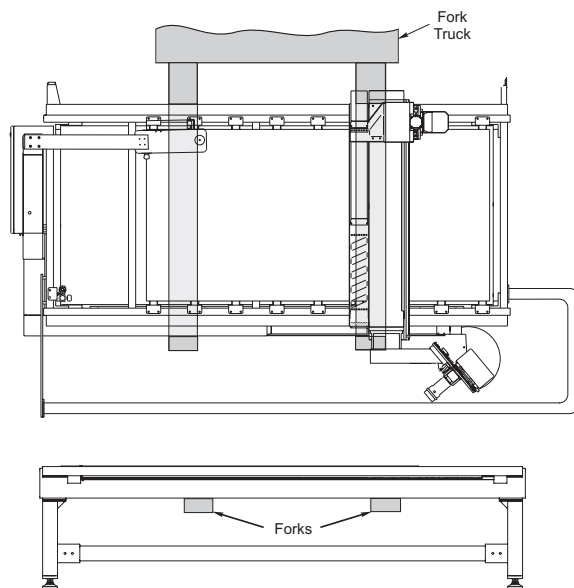



SHIPPING BRACKET REMOVAL

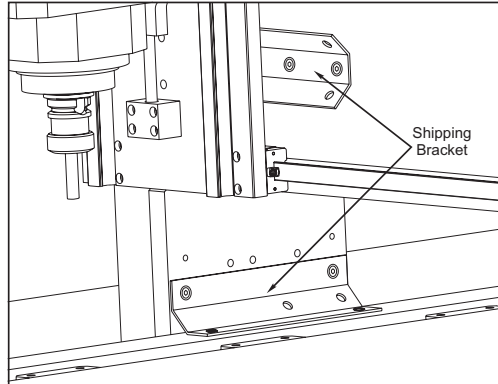

Three shipping brackets are used with the SR-100. One is located on the bridge to prevent the spindle from moving along the bridge. One bracket is attached to each bridge column to secure the bridge to the table to prevent the bridge from moving during shipping.

Remove the two BHCS from the bracket holding the spindle and after removing the bracket, put the screws back in the holes to plug them. Remove the four SHCS from each of the brackets securing the bridge to the table.

Remove and retain the cap from the spindle nose. This cap will be used to protect the spindle taper when the machine is not in use.

PENDANT POSITION

1. Remove the four screws from the top of the pendant arm.
2. Rotate the pendant from the shipping position to the operating position (90°).
3. Re-install the four screws into the top of the pendant arm.

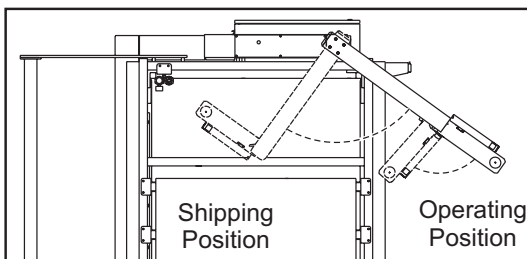

4. Remove the shipping bracket from the control pendant and rotate it to operating position.



5. Remove the rear cover from the control pendant. Locate the second pendant hard stop screw included in the plastic bag included with the machine and install it to the swivel as shown, then replace the rear cover. The pendant should now swing approximately 90° as shown in the following illustration.

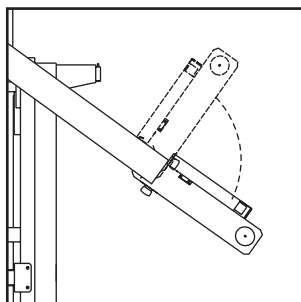

OPERATOR GUARD

The operator guard is not installed on the SR-100 when shipped.

1. Remove the four screws from each end of the machine.

NOTE: Be sure that the guard spacers remain in place.

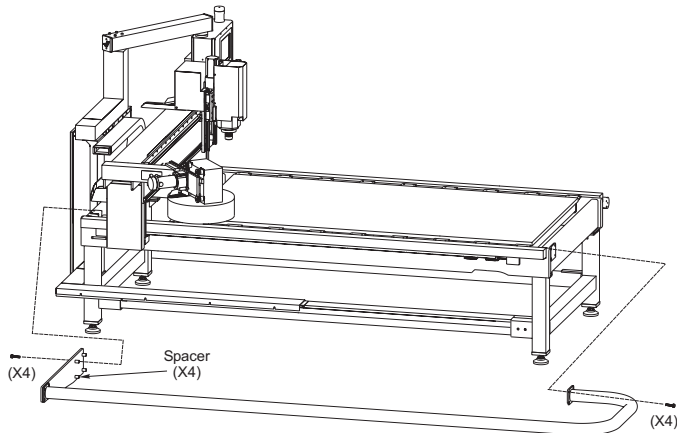

2. Lift the operator guard into position use the removed screws to secure it in place.



PHOTOELECTRIC BEAMS

WARNING

The electric safety guard must be set up before jogging any axis.

The SR-100 comes with a photoelectric beam and reflector for the operator side of the machine. Once this system is set up the machine will halt should personnel or equipment enter the protected area. The beam fixtures are located at each corner of the right side of the machine, and scan the length of the table. Note that the width is not protected. The machine will go into feed hold and the spindle will stop if the electronic beam is broken. When this happens, clear the area close to the machine of personnel or equipment and press Cycle Start to continue.

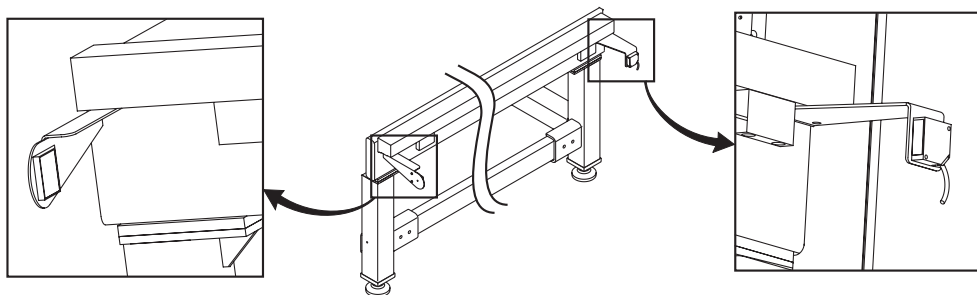

Photoelectric Beam Setup (Exploded Views Rotated for Clarity)

Set-up

The right side of the table is equipped for a bracket with a reflector and a bracket with a sensor. These need to be installed correctly in order for the system to function.

1. At the rear of the operator side of the machine, loosen the single bolt, swing the reflector bracket into position (90°) and snug the bolt down on the bracket.
2. At the front of the operator side of the machine, remove the unused bolt and loosen the bolt holding the bracket with the photoelectric beam generator in position. Swing the bracket into position (90°) and use both bolts to secure the bracket. Adjust the beam until both lights on the sensor are lit.
3. Once aligned, tighten all the bolts. Verify that both of the sensor lights are still on.

LEVELING

Leveling of the machine is required to obtain the correct right angle geometry of the X, Y, and Z axes. Incorrect leveling will result in out-of-round circle milling and incorrect linear interpolation.



Use a precision bubble level with each division equal to **0.0005** inch per **10** inches, or **.05** mm per meter, or **10** seconds per division. Before starting, check the accuracy of your level. Set it on the table on the X-axis and record the reading. Then turn it **180°** and the reading should be the same. If it is not, the level is out of calibration and should be adjusted before you continue.

Screw the four leveling screws at the corners until the base is 2½" to 3" above the floor. The jam nuts on the leveling screws will be tightened at the end of the leveling procedure.

NOTE: These leveling procedures can be completed more efficiently by using two levels, one along the X-axis and one along the Y-axis. Check that both levels are properly calibrated before continuing.

Rough Leveling

1. Place the precision bubble level on the center of the table parallel with the table (X-axis).
2. If the bubble goes to the front of the level, then the front end of the machine is high. Conversely, if the bubble goes to the rear, it means that the rear end is high. Raise the two front or back leveling screws evenly until the bubble is centered.
3. Rotate the level 90° parallel with the Y-axis. Adjust the right or left leveling screws as needed until level.
4. Repeat this process until both directions are level.

Remove Pitch and Roll (Twist)

1. Use Handle Jog set for **0.01** on the X-axis for this procedure. This provides a good rate of travel for manually moving the bridge.
2. Jog the X-axis to machine zero and the Y-axis to the middle of travel.
3. Place the level on the bridge parallel to the X-axis to check the pitch. Zero the level by shimming it.
4. Jog the bridge to the other end to the machine. If the bubble goes to the front of the level, then the front end of the machine is high. Conversely, if the bubble goes to the rear, it means that the rear end is high. Raise both screws on the low end until level.
5. Place the level parallel to the Y-axis on the bridge to check roll on the table. Zero the level by shimming it.
6. Jog the bridge to the other end of the machine. If the bubble goes toward the right, the right side of the machine is too high. Conversely, if the bubble goes to the left, the left side is too high. Adjust as needed.
7. As the process continues, the leveling screws are turned in smaller increments — 1/4 turn, 1/8 turn, etc.



Repeat these steps until the machine is level. When leveling is completed, tighten the jam nuts on the leveling screws. Check again that **all** the pads of the leveling screws are sitting firmly on the floor.

Check the leveling screws a few days after installation. The foundation may settle which could affect the machine's stability.

2. OPERATION

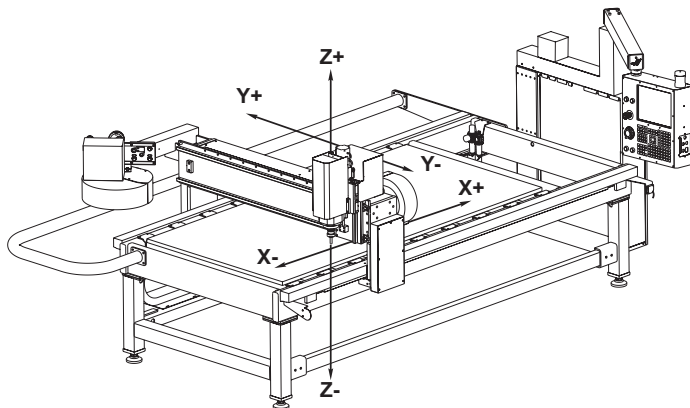

Startup and Operation

Never run the spindle without a tool holder installed! The “Tool Unclamp” warning message will prevent spindle operation without a tool in the spindle.

If the SR-100 is powered up with no tool in the spindle, Alarm 131 (Tool Not Clamped) will appear in addition to Alarm 102. Both alarms can be cleared using the Reset button.

Note that Alarm 131 on startup does not indicate a problem with the air solenoid, I/O assembly, drawbar assembly or wiring.

Tool Changer

Follow these specifications to avoid damaging the tool changer:

- Use the correct tooling: ISO30.
- The maximum tool weight allowable is 8 lbs per pocket, 80 lbs total, with 3.5” maximum tool diameters.

Table

- The maximum weight allowable on the SR-100 table is 500 lbs distributed evenly.
- The maximum weight allowable on the SR-200 table is 1000 lbs distributed evenly.



Spindle

Every day, when the spindle is started up for the first time, let it warm up slowly without load. This ensures that the bearings reach their running temperature gradually, and that the bearing races expand evenly.

The following warming up cycle is recommended, to be performed **with the tool holder in place** but without actually machining (no load):

- 50% maximum rated speed for 2 minutes.
- 75% maximum rated speed for 2 minutes.
- 100% maximum rated speed for 1 minute.

Warm the spindle up before machining whenever the machine has been left idle long enough for it to cool down to ambient temperature.

At the end of the work day, allow air to continue to flow through the machine for 15 minutes before shutting off the air valve. This can be done before or after shutting down electric power. Shut off the air valve near the supply connection, then remove the tool from the spindle and place the protective cover on the spindle nose. **DO NOT** leave a tool in the spindle, as it may stick.

NEVER blow compressed air directly into the spindle nose!

NOTE: In order to manually remove a tool from the spindle using the Tool Release button on the control, the photoelectric safety beam must be broken.

3. MAINTENANCE

Linear Guides and Z-axis Ballscrew

The linear guides and Z-axis ballscrew are lubricated manually with a general purpose lithium grease by means of grease fittings located on the machine. They must be lubricated once a month. Pump with 2 strokes of the included grease gun at each fitting.

CAUTION! Do not over-grease! Damage to the machine may occur.



The four (4) grease fittings for the Y-axis and 4 grease fittings for the Z-axis linear guides are located beside the spindle, two (2) to each side. Each column has two (2) grease fittings mounted in it, one on either side, for the X-axis linear guides. The Z-axis ballscrew grease fitting is located between the Z-axis linear guide grease fittings on the operator side of the spindle.

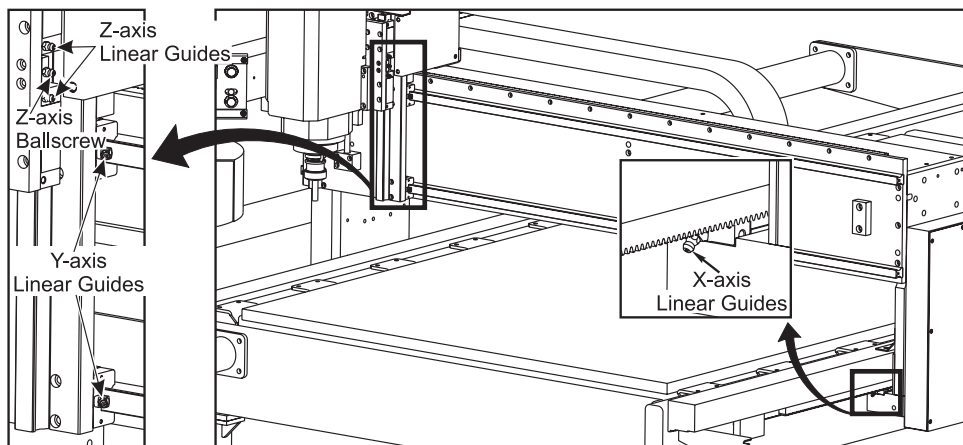

SR-100 Grease Fittings

Gear Racks, X and Y Axes

Periodically inspect for chips, dust and debris, and clean with the air nozzle. Use light machine oil applied with a clean soft rag weekly to maintain lubrication.

Spindle

The spindle bearings are greased for life and do not require maintenance.

Daily - Clean the tool holder and spindle tapers with a soft cloth. **DO NOT** use abrasive tools or materials, or aggressive chemicals or acids to clean these parts.

Every Two Weeks - Carefully clean the tool holder and spindle tapers with a clean, soft cloth dipped in ethyl alcohol.