

Door Interlock

Wire fence
not solid walls

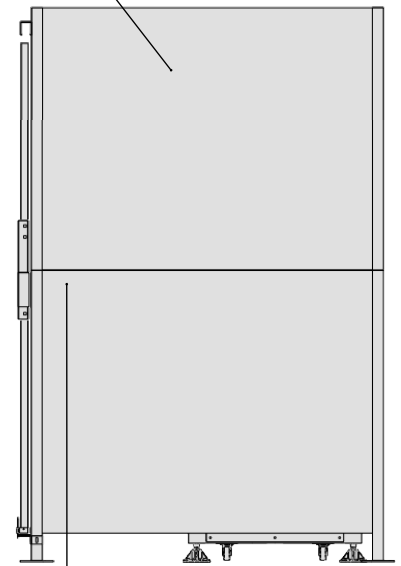

Sample position of remote E-Stop

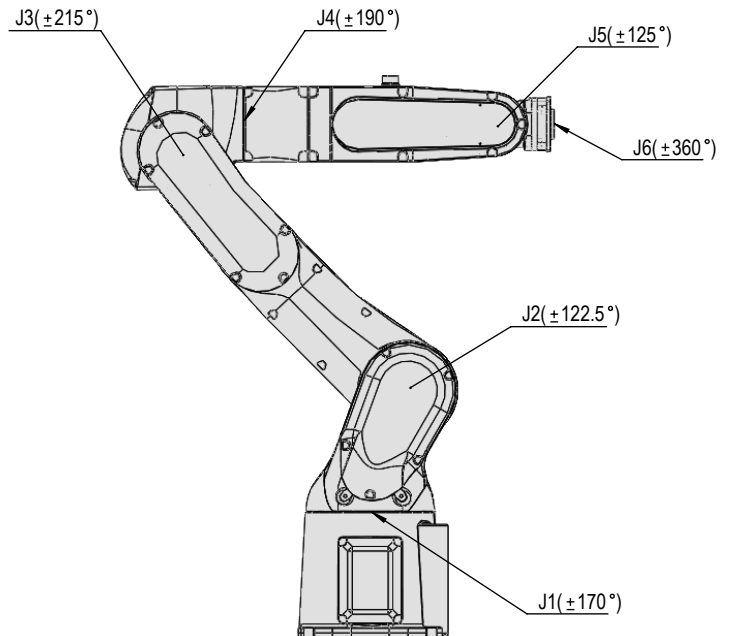
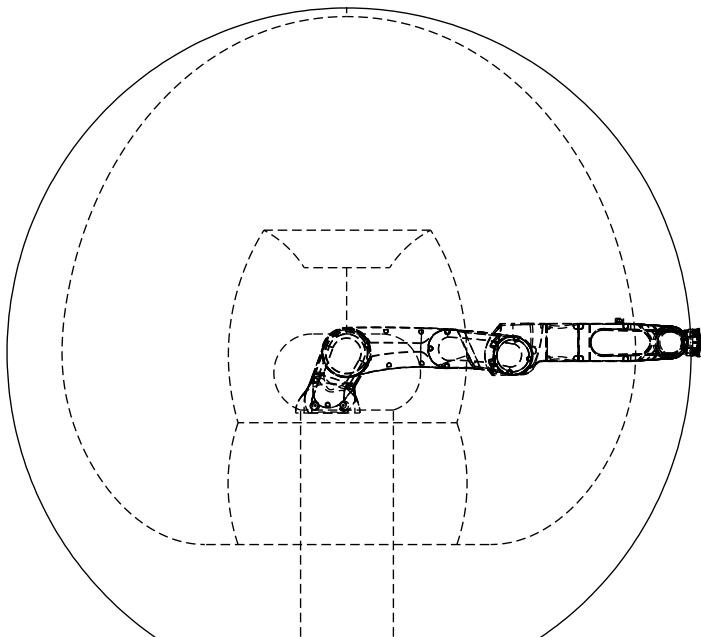
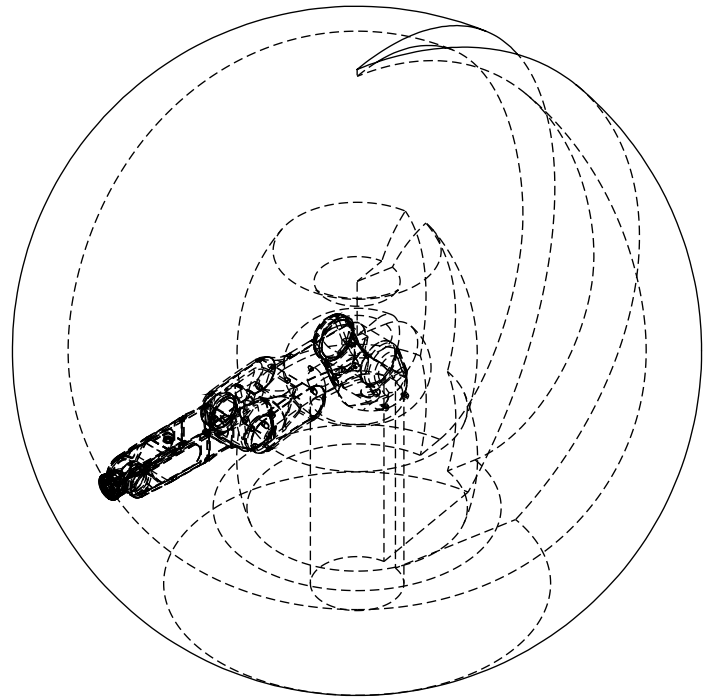
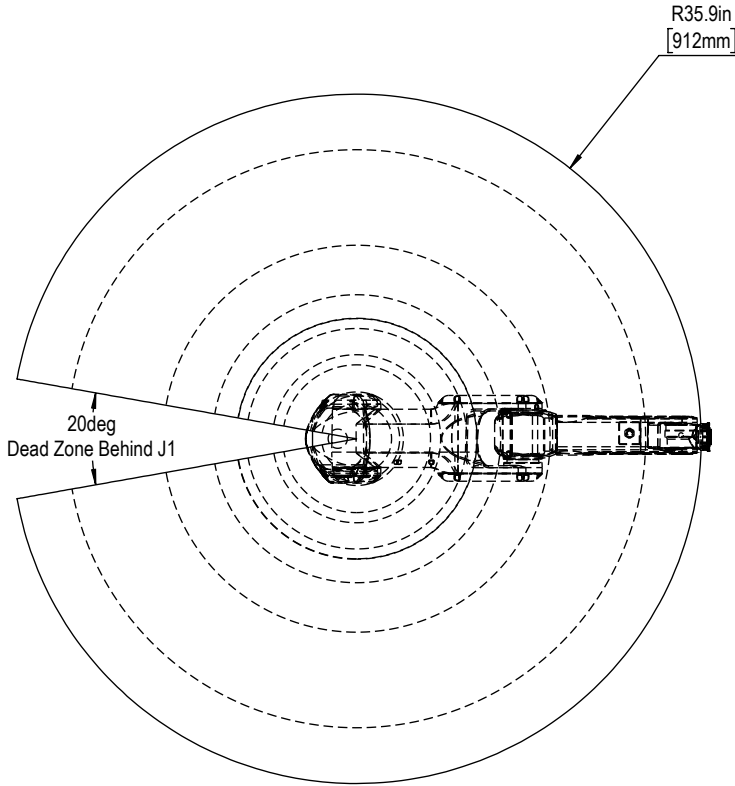

Robot model is FANUC LR Mate 200iD/7L

Maximum payload from wrist is 15lbs [7kg]
That is gripper + material = <15lb

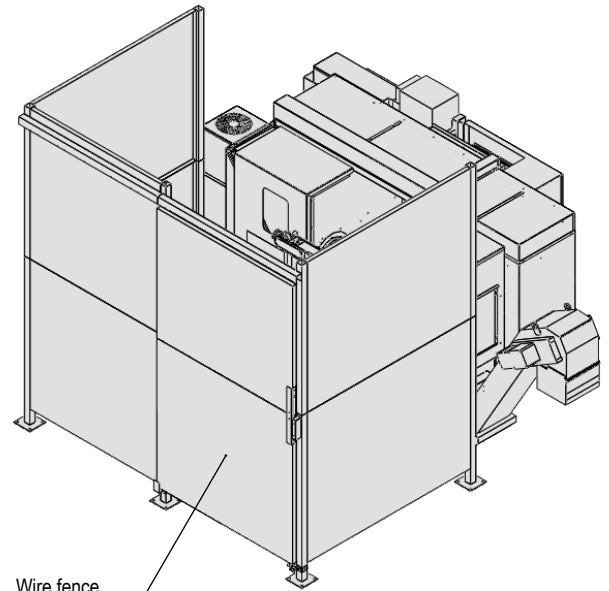
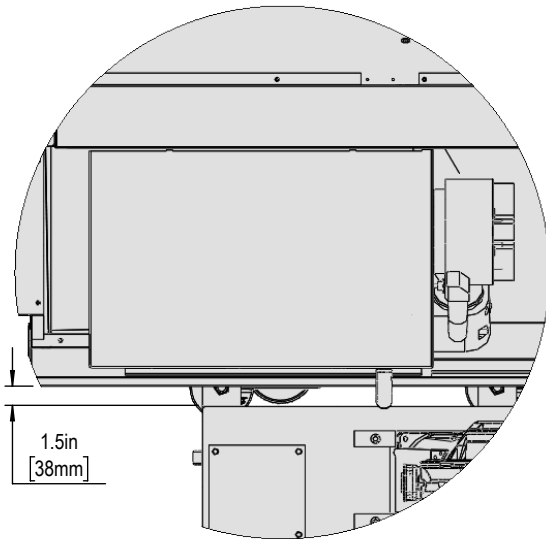

VIEW A

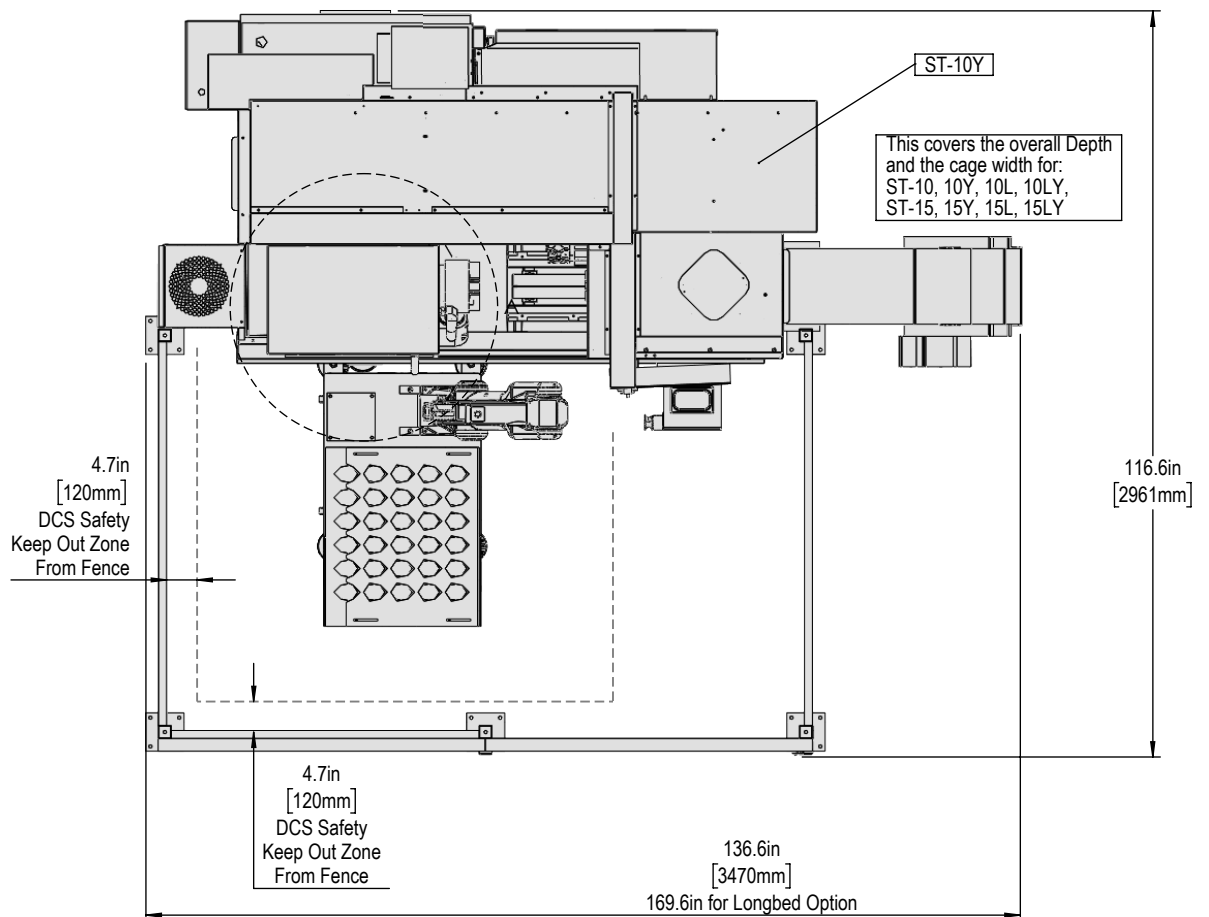

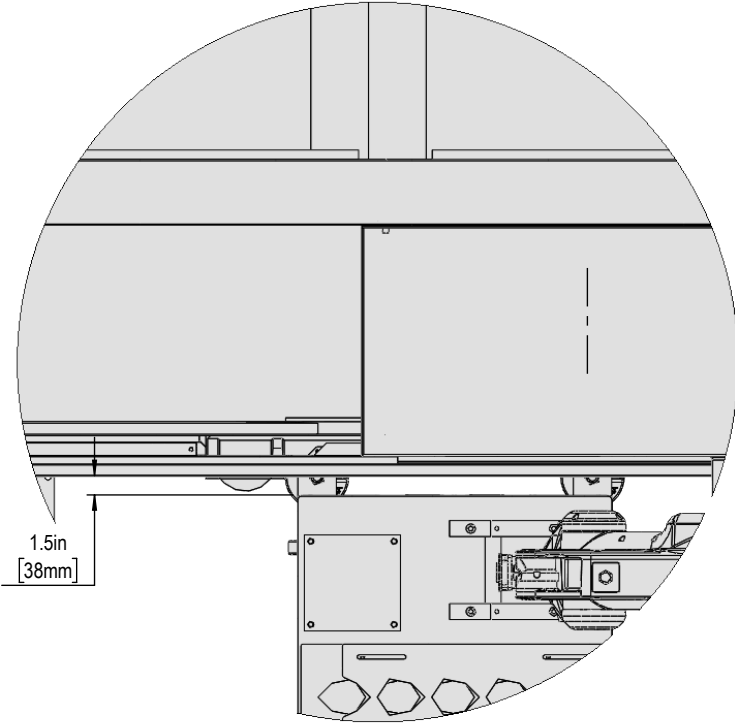

VIEW B

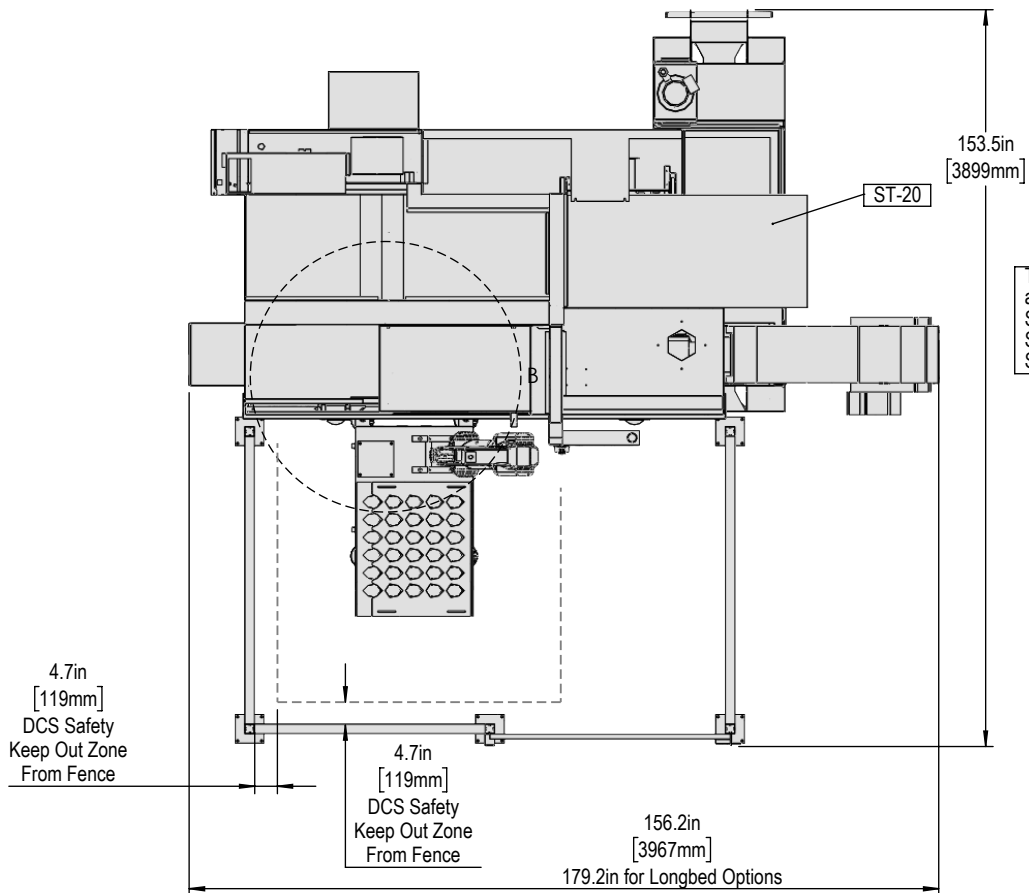
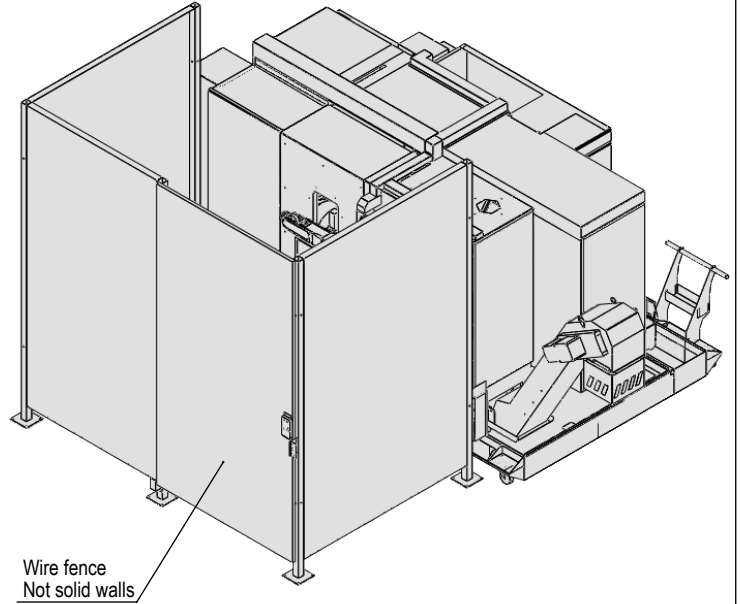

This covers the overall Depth and the cage width for the:
 ST-20, 20Y, 20L, 20LY,
 ST-25, 25Y, 25L, 25LY,
 ST-28, 28Y, 28L, 28LY

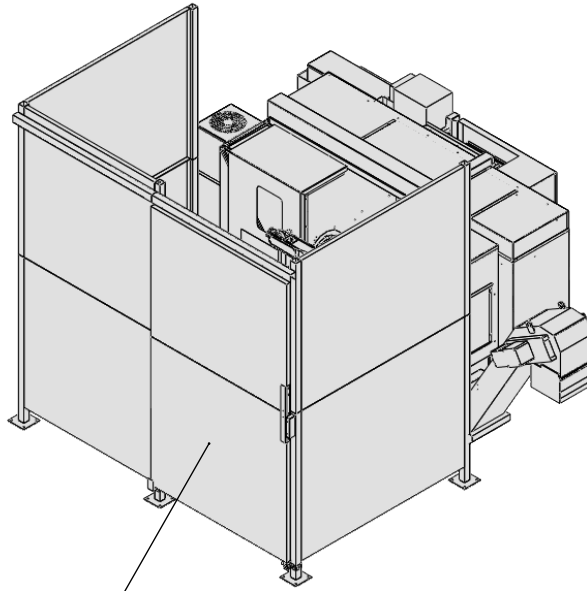

Wire fence
Not solid walls

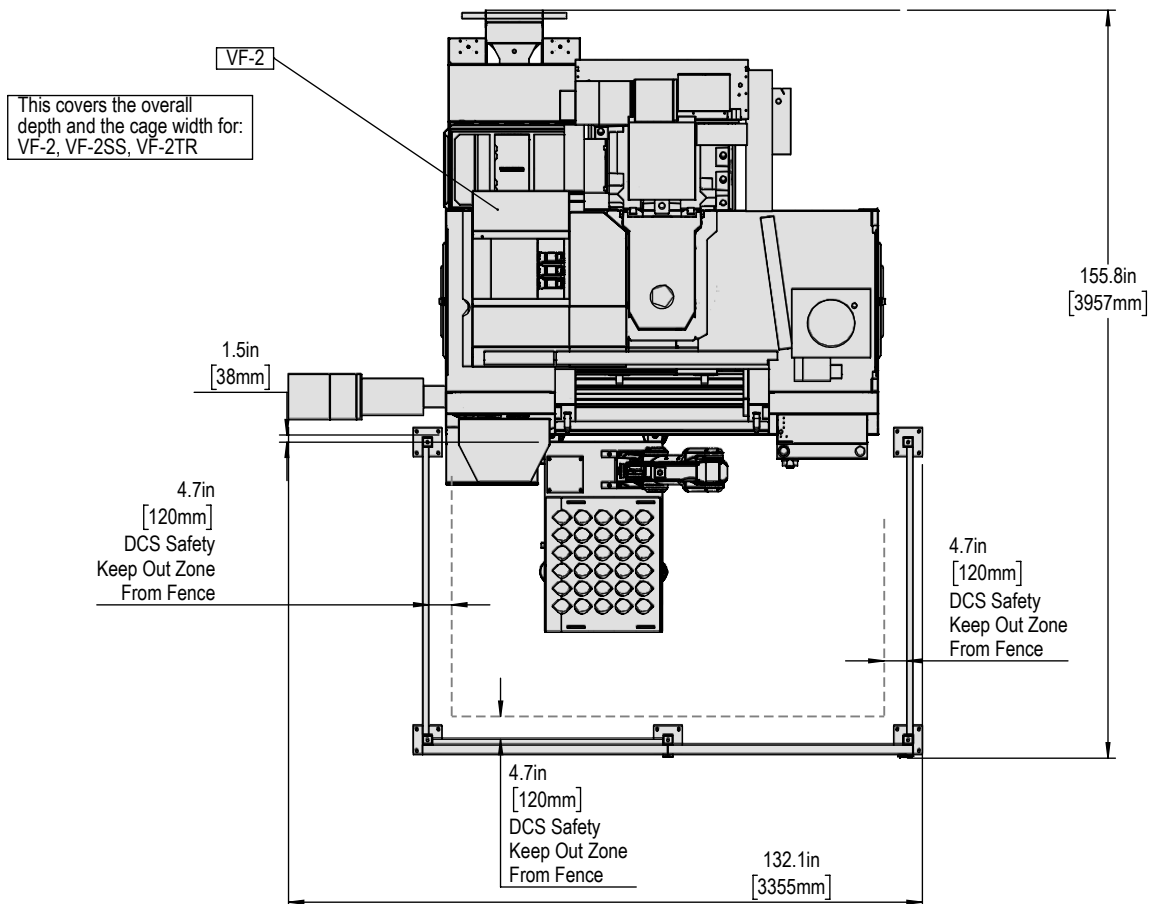

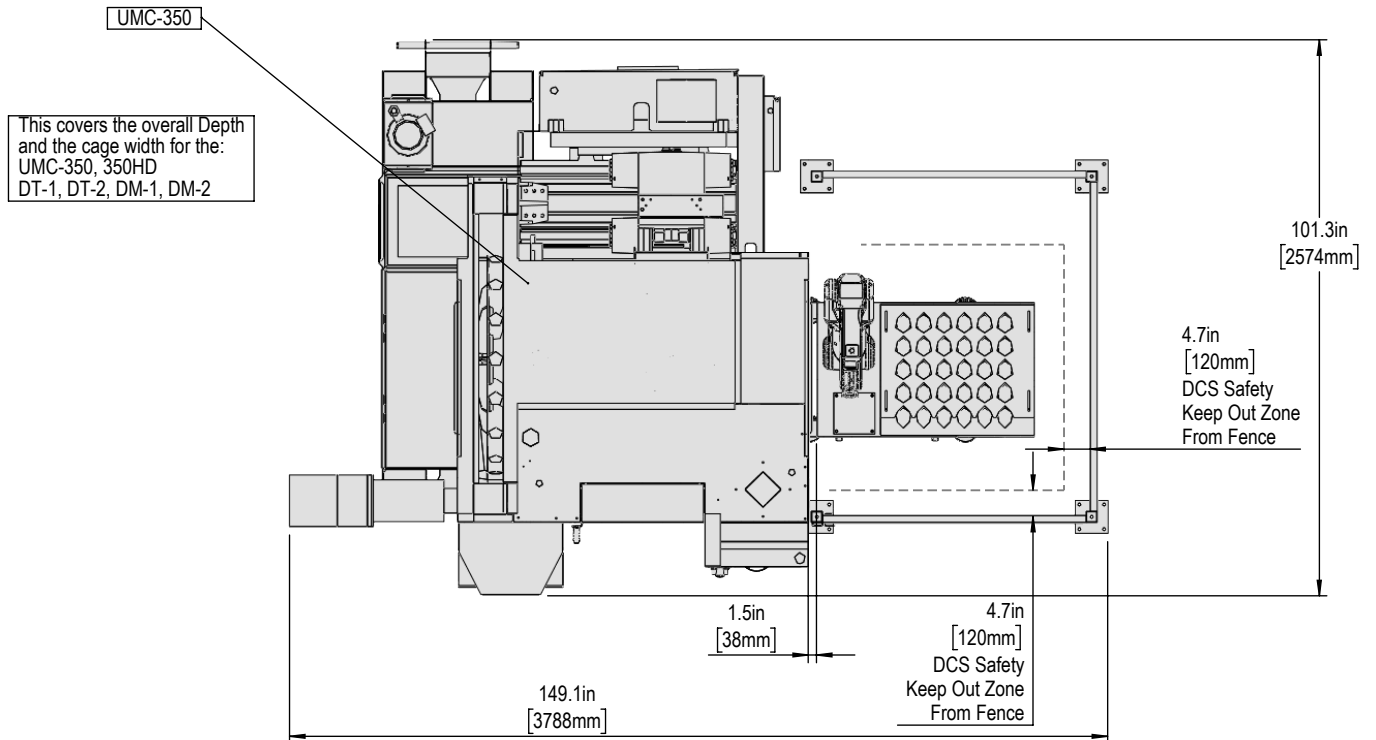
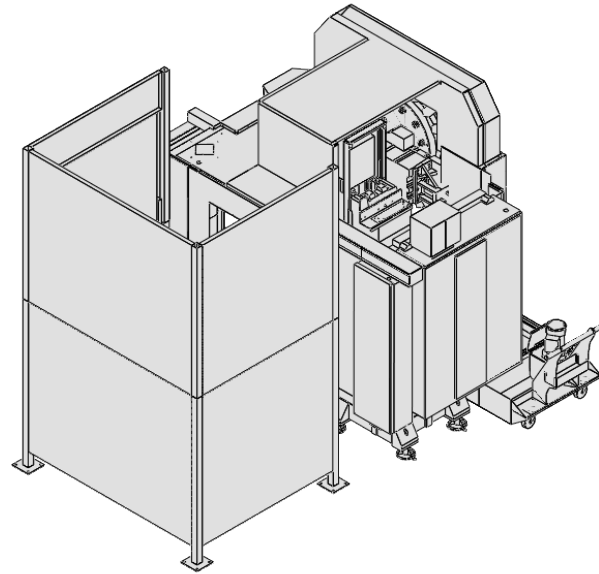

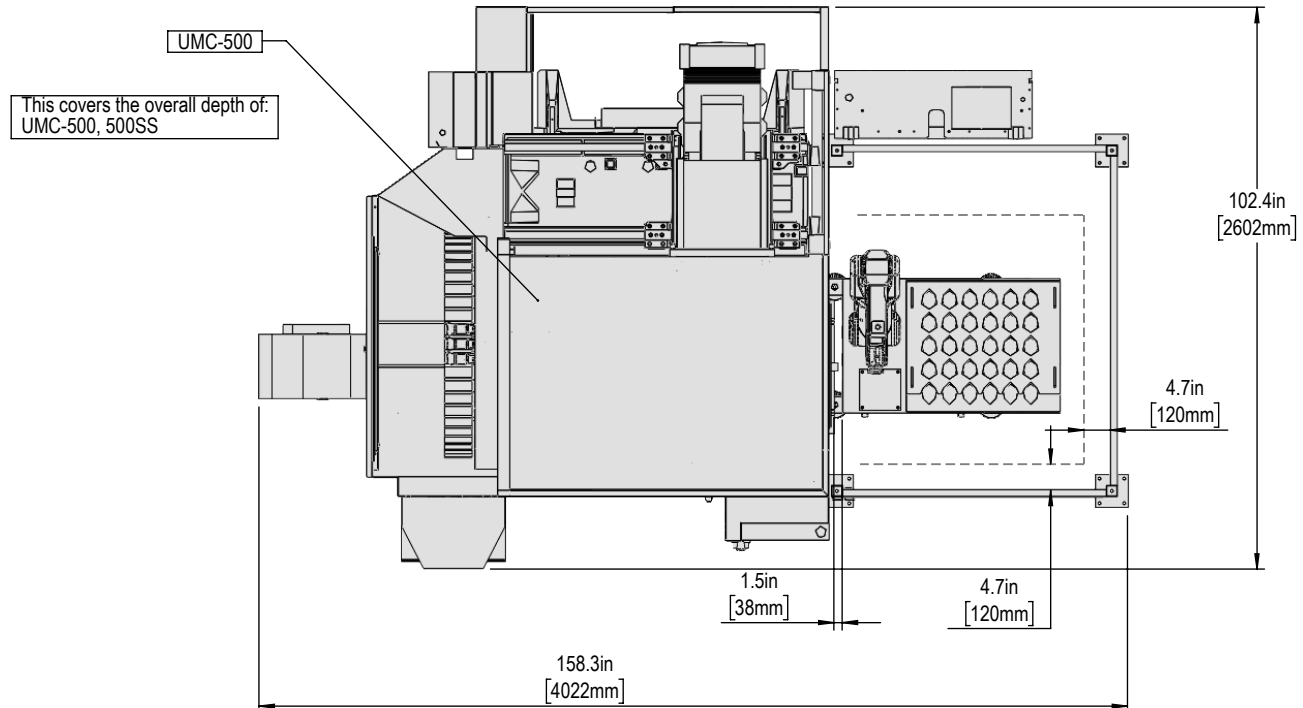
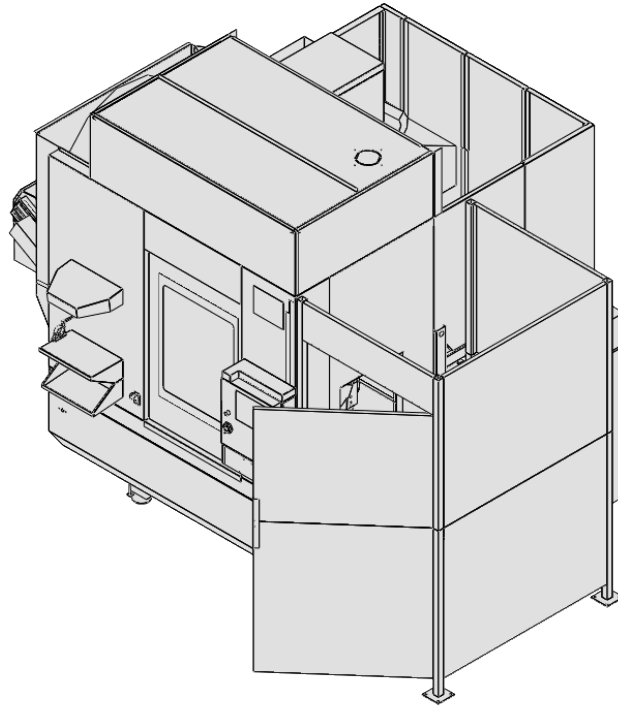

DT,DM, and UMC productlines get the straight base.

Lathes and Verticals get the angled base.

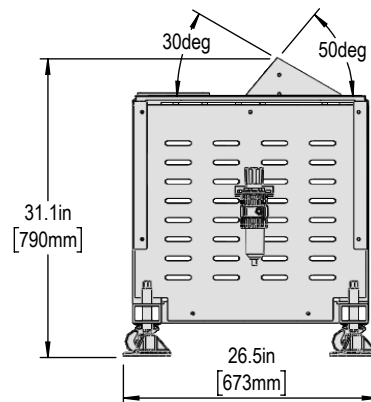
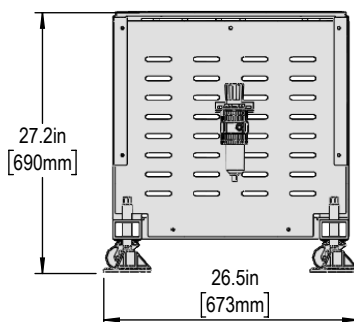
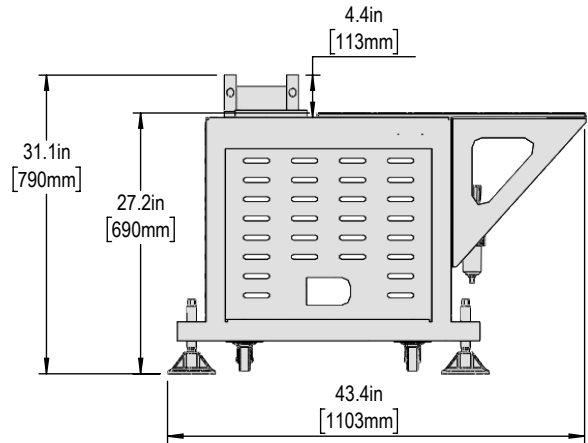
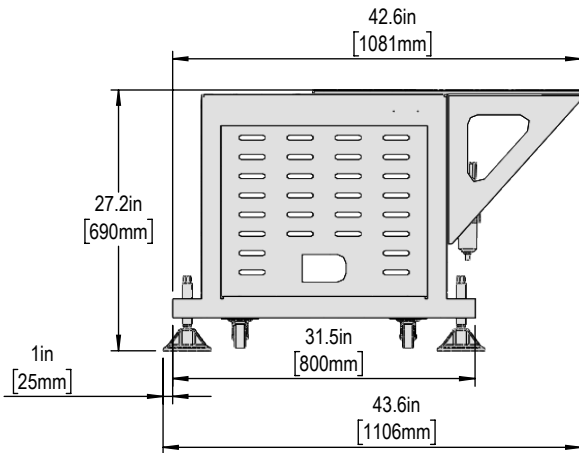
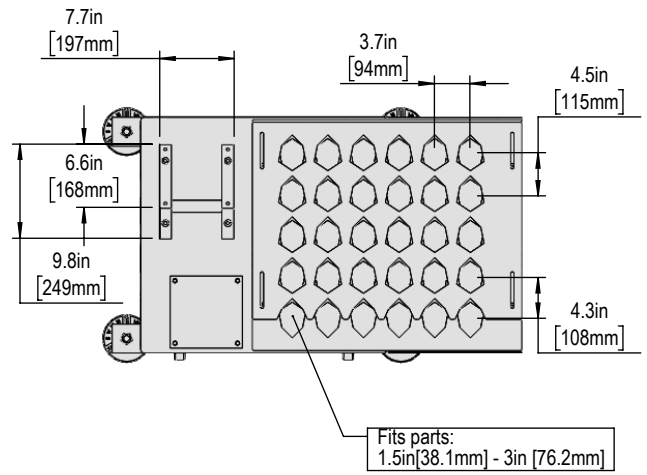
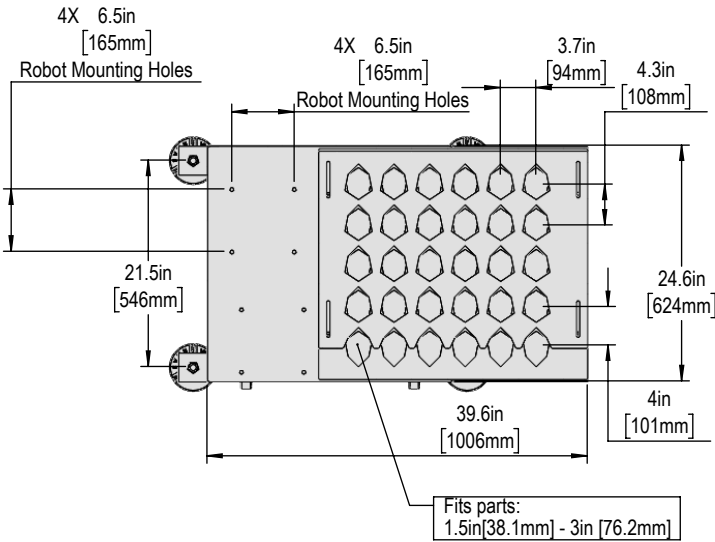



Total weight of the Single Slug Gripper is about 3.75lbs [1.7kg]

Maximum Part Weight: About 11.25 lb [5.1kg]

Minimum Part Size: 0.625in [16mm]

Maximum Part Size: 6in [152mm]

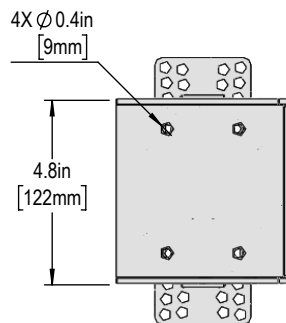
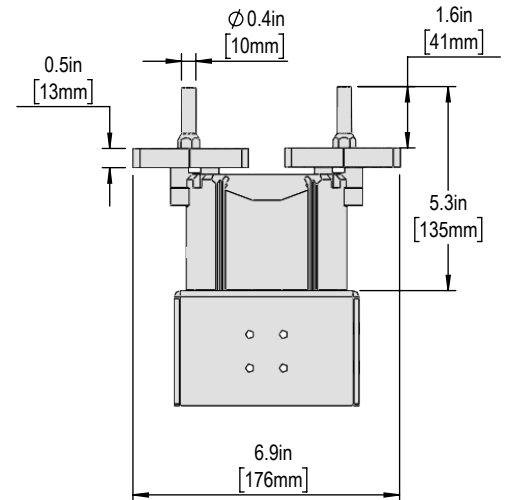
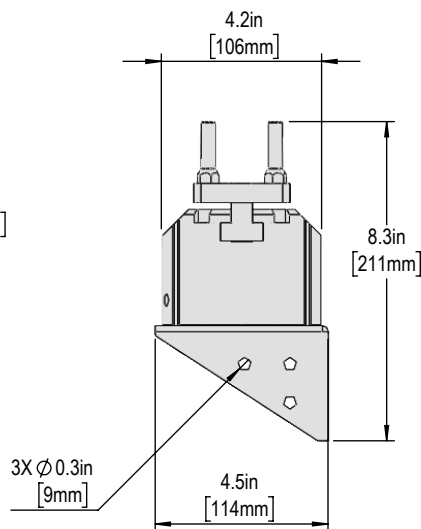
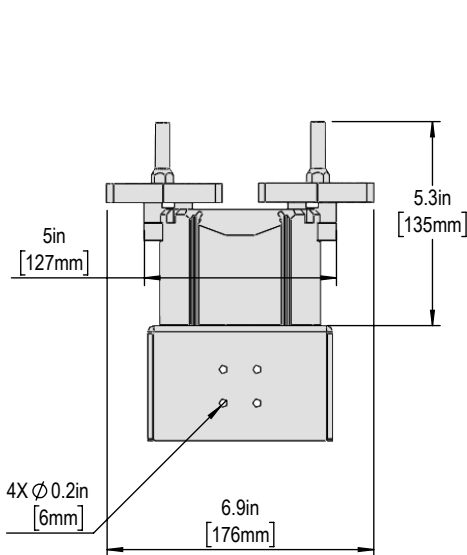
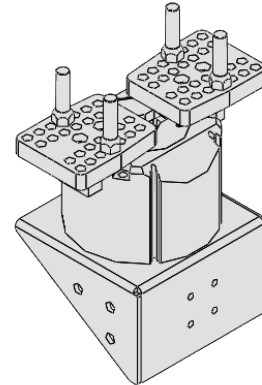
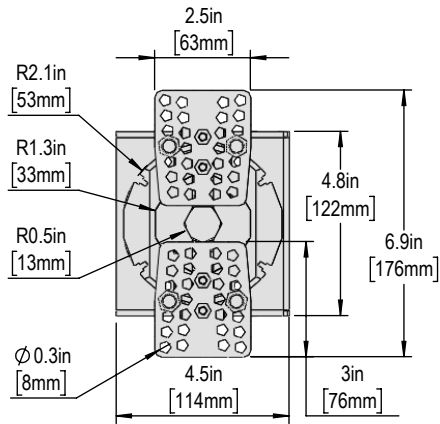

Total weight of the Dual Slug Gripper is about 9lbs [4kg]

Maximum Part Weight per gripper: About 3 lb [1.4kg]

Maximum Part Weight both grippers: About 6 lb [2.7kg]

Minimum Part Size: 0.625in [16mm]

Maximum Part Size: 6in [152mm]

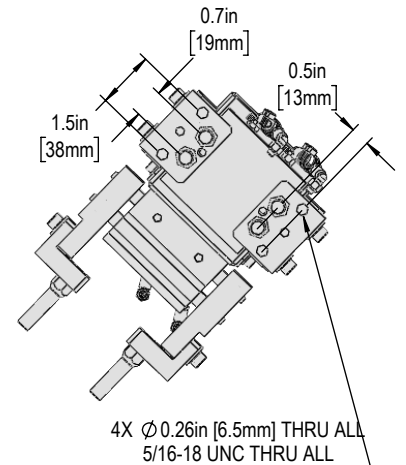
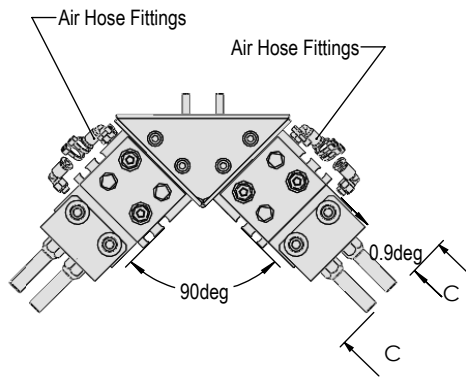
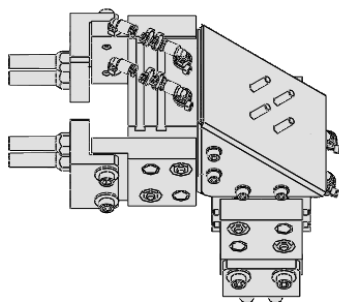
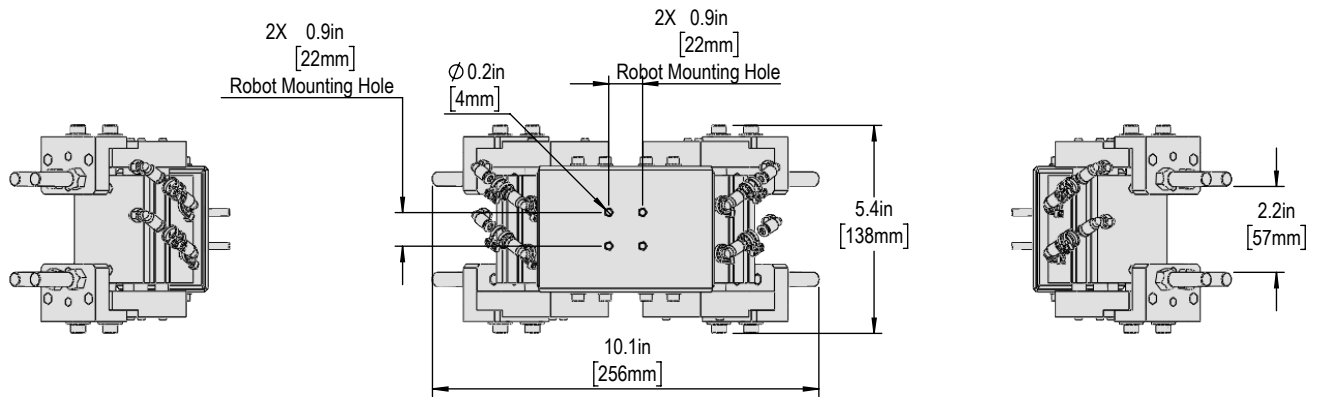
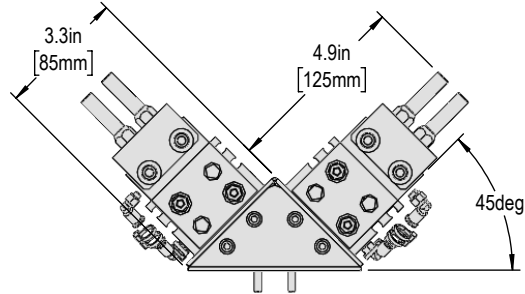

SECTION C-C