

Technical Details

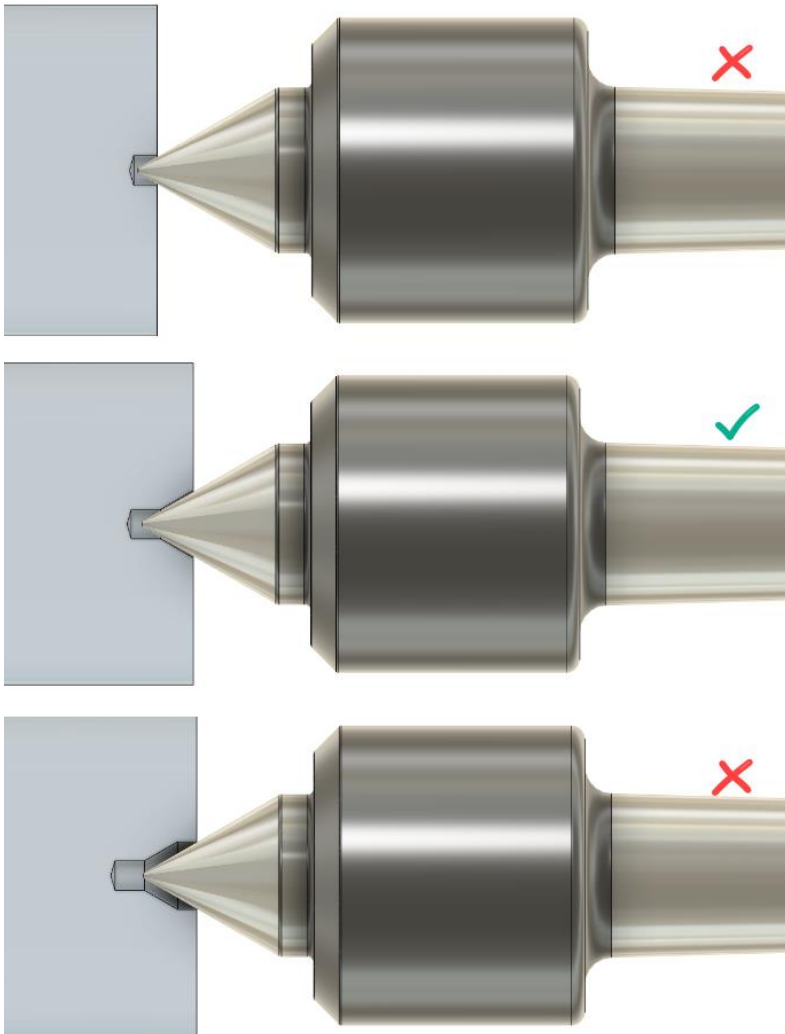

CENTER DRILL DEPTH



Incorrect drill depths being too shallow or too deep will lead to improper work holding. Which may cause imbalance in the work piece, incorrect dimensions or poor finishes.

Use the table below to find the recommended depth range of your center drill.

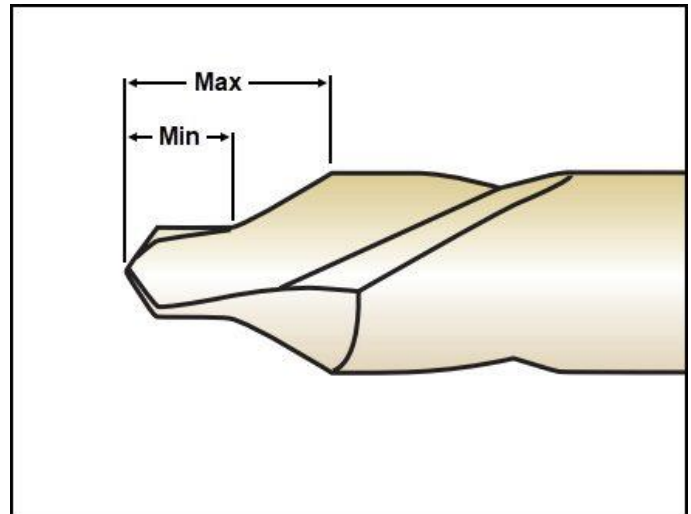

Haas Part #	[D2] Shank Diameter	[D1] Drill Diameter	Maximum Drill Depth	Minimum Drill Depth
03-1844	3.15 mm	1.25 mm	2.74 mm	2.11 mm
03-1845	4.0 mm	1.6 mm	3.59 mm	2.51 mm
03-1846	5.0 mm	2.0 mm	4.59 mm	3.01 mm
03-1847	6.3 mm	2.5 mm	5.89 mm	3.61 mm
03-1848	8.0 mm	3.15 mm	7.59 mm	4.41 mm
03-1849	10.0 mm	4.0 mm	9.69 mm	5.51 mm
03-1850	12.5 mm	5.0 mm	12.29 mm	6.81 mm