

Tool Holder Accessories

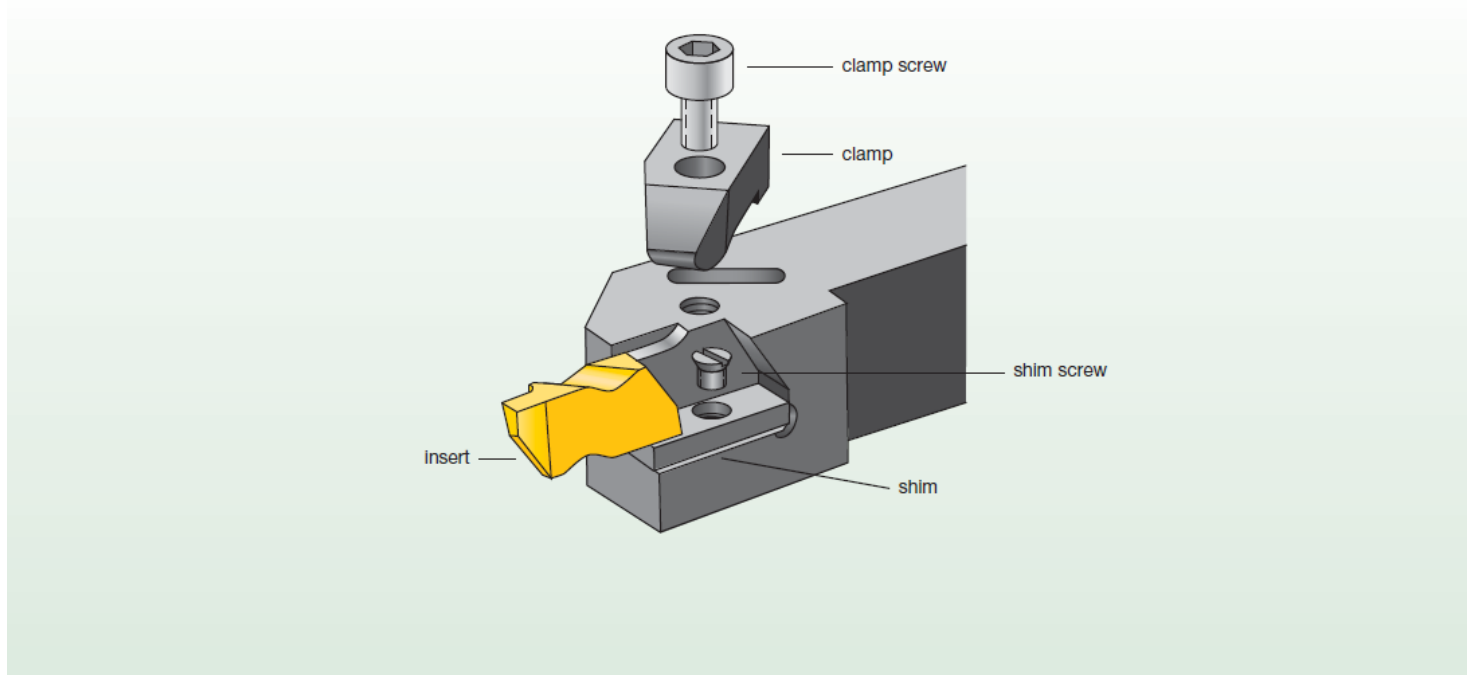

insert size and style



clamp



clamp screw

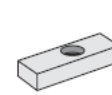

shim



shim screw

Applies to Both OD and ID tool holders
Shim and Shim screw not required for all tool holders. Check related products

Technical Details



The insert size must match the gage insert size of your toolholder selection:

Required Information:

- External/internal operation.
- Minimum bore diameter (for internal operations).
- Hand of tool.
- Insert size (gage insert).

Haas Holder Description	Insert Size
HNSR163D	3
HNSR164D	4

NOTE: Haas Notch toolholders and boring bars are listed with a gage insert to indicate the size and hand required. They are compatible with both grooving and threading inserts of the same size.

Select the appropriate holder for the insert size and hand:

