

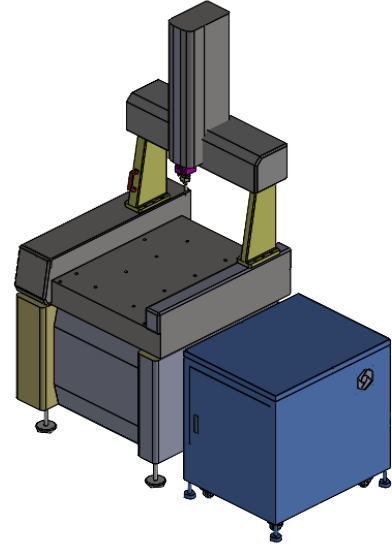

INSTALLED DIMENSIONS

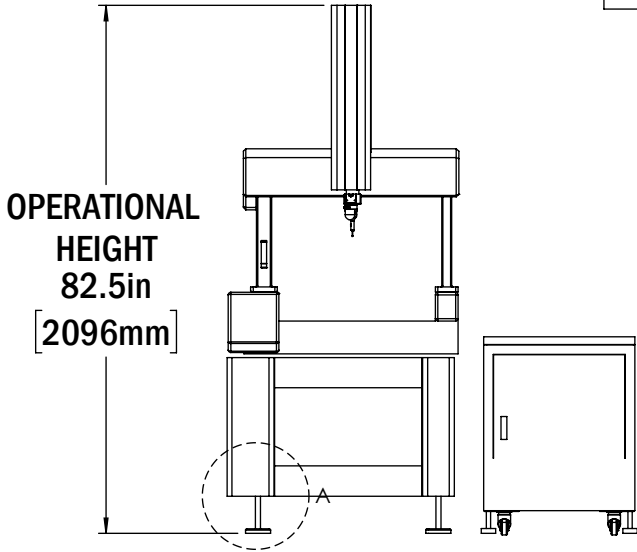

LEVELING PAD HEIGHT

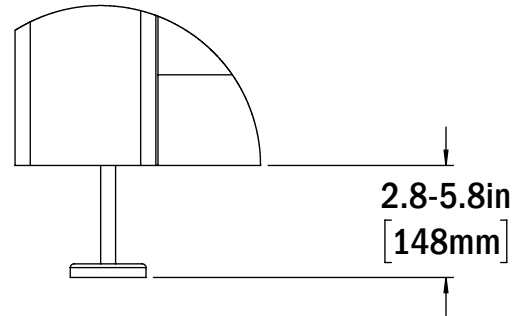

**OPERATIONAL WIDTH**  
64.1in  
[1628mm]

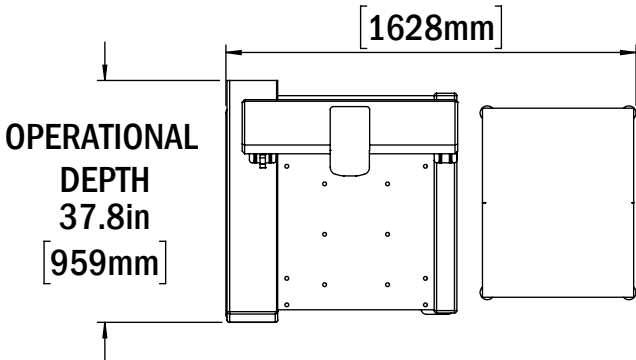

SHIPPING DIMENSIONS

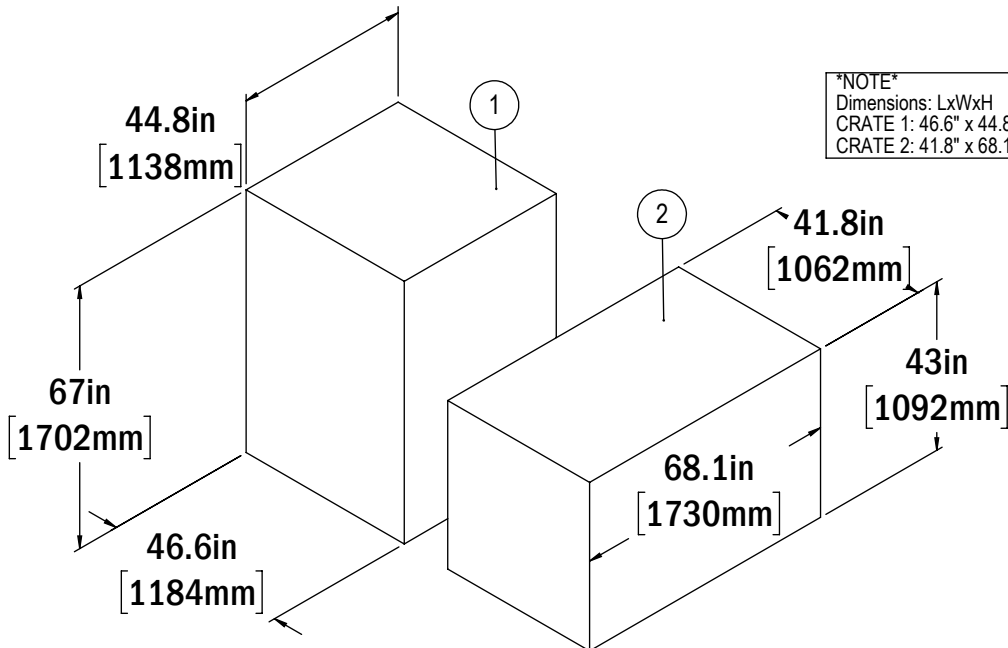

**\*NOTE\***  
Dimensions: LxWxH  
CRATE 1: 46.6" x 44.8" x 67.0" \ 1184 x 1138 x 1702 mm  
CRATE 2: 41.8" x 68.1" x 43.0" \ 1062 x 1730 x 1092 mm



WALL CLEARANCES

POWER

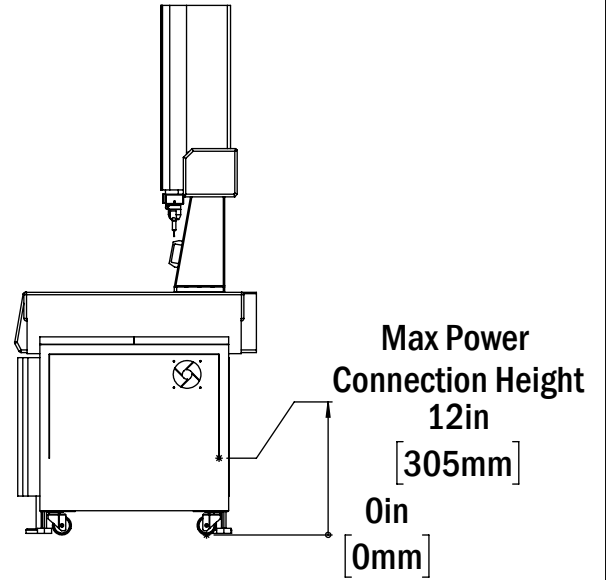
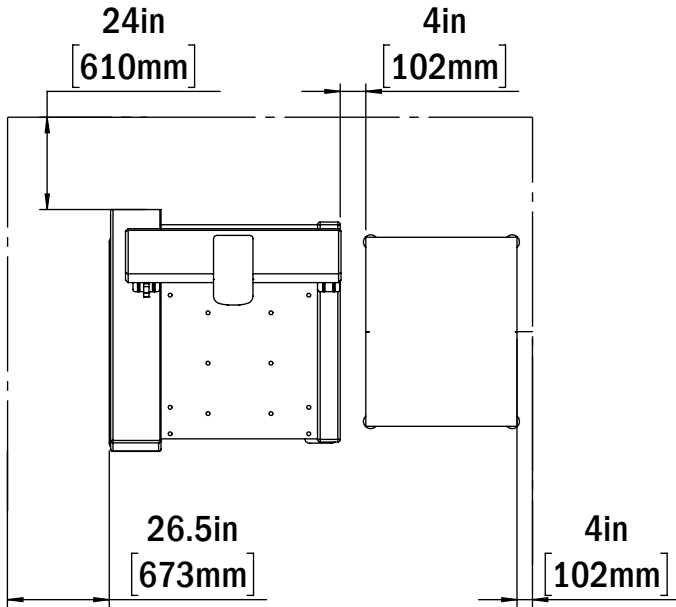

WIDTH BREAKDOWN

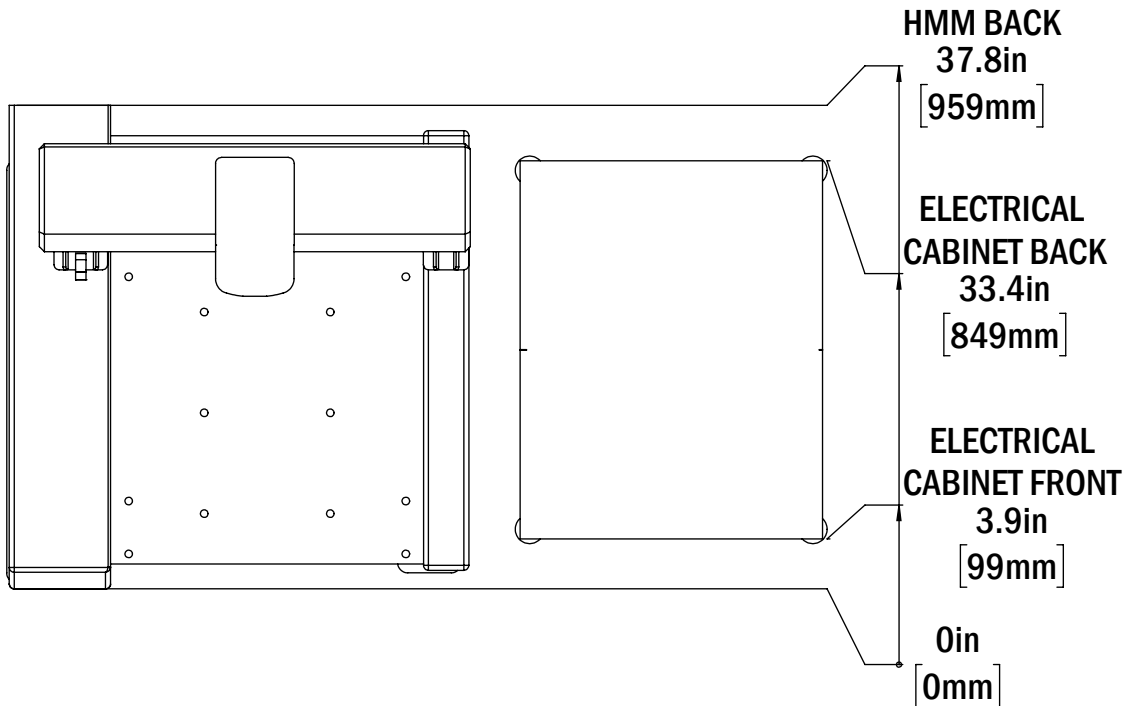



HEIGHT BREAKDOWN

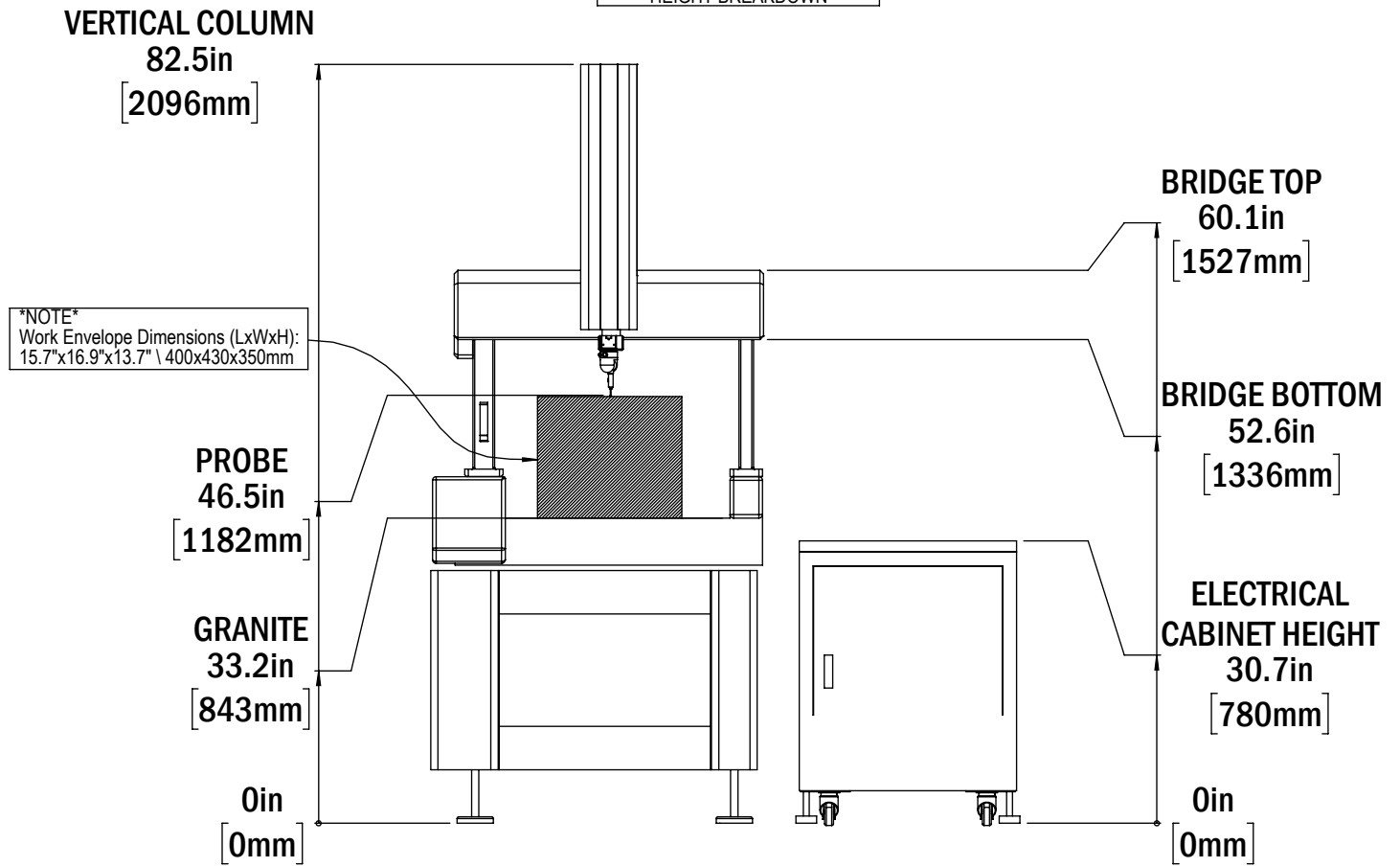

X&Y- Axes Travel and Clearance

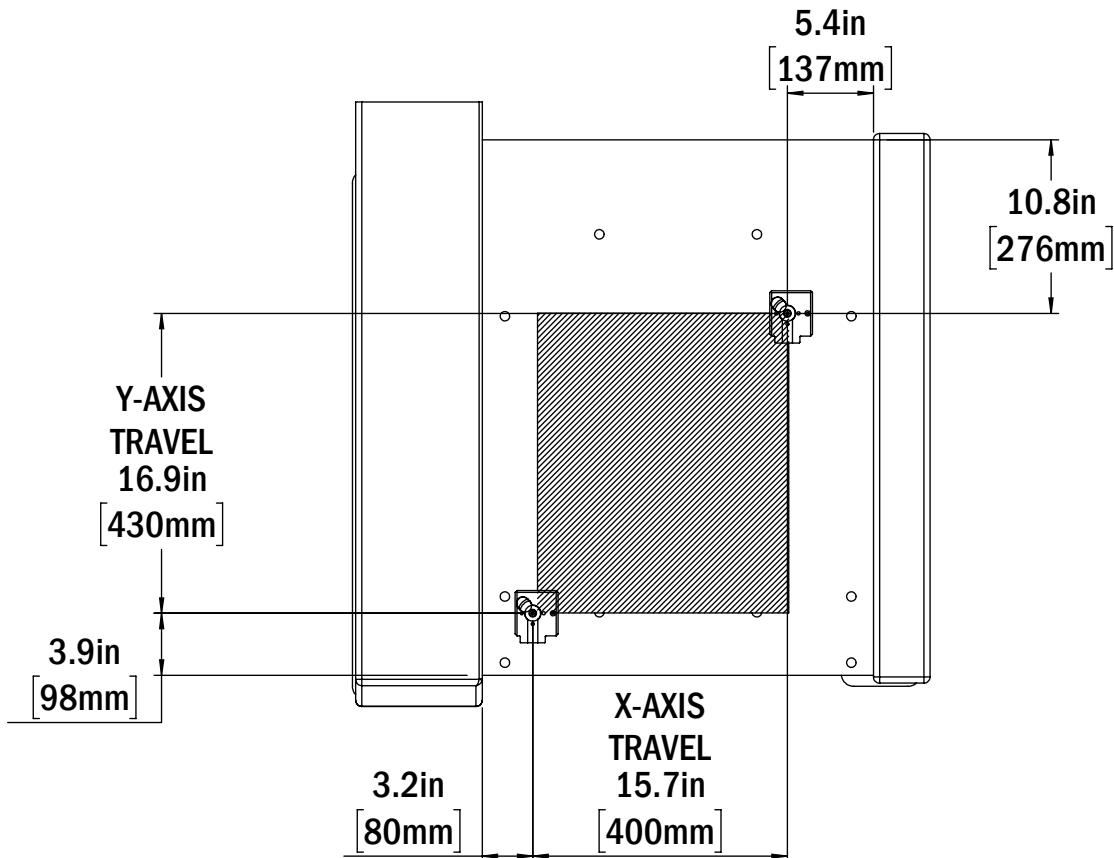



Z-AXIS TRAVEL AND CLEARANCE

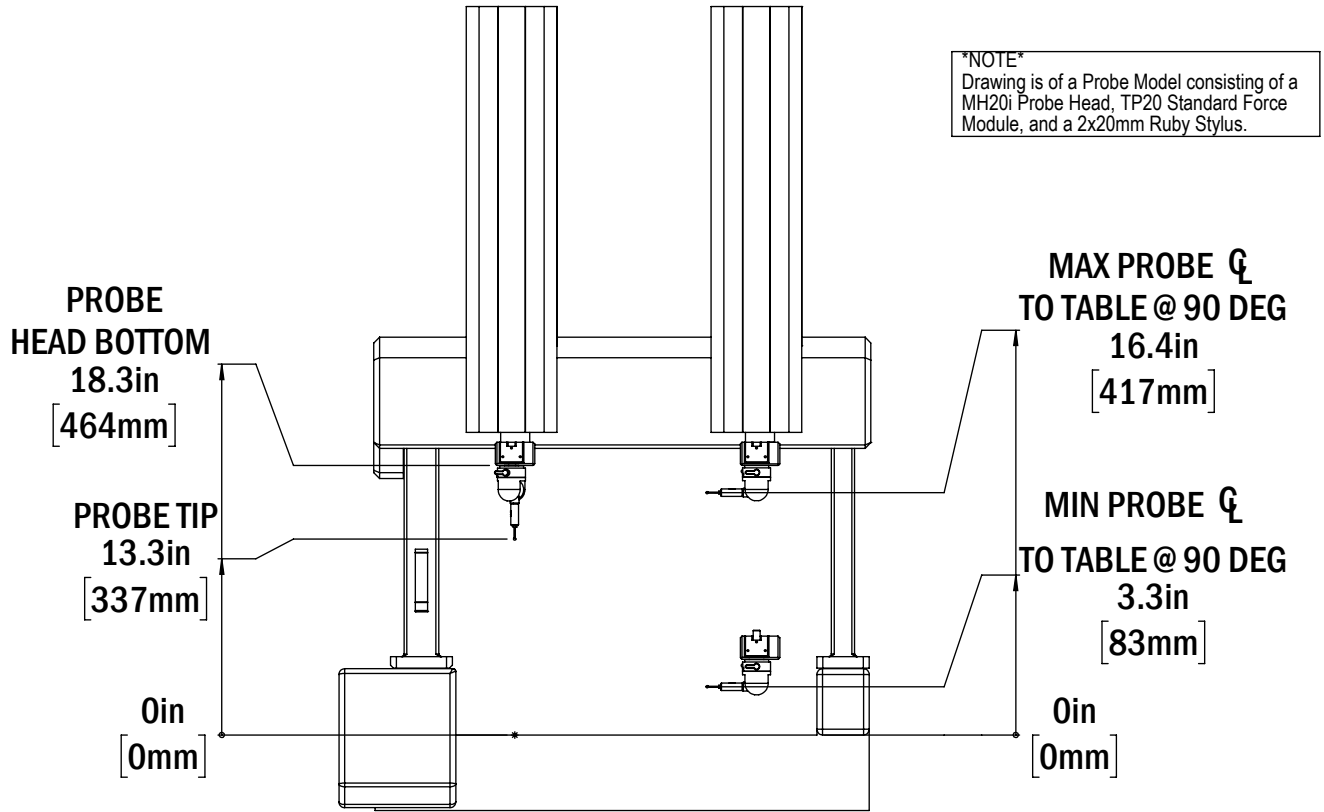

HMM430 Setup with Work Envelope

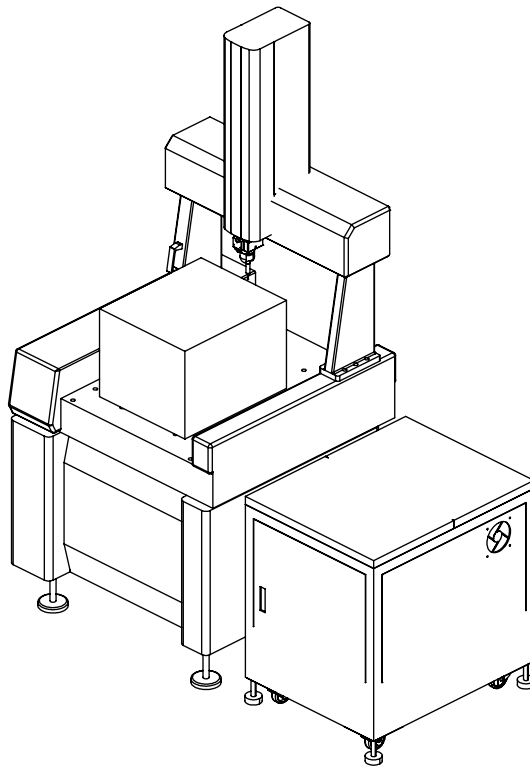

**\*NOTE\***  
Work Envelope Dimensions (LxWxH):  
15.7"x16.9"x13.7" \ 400x430x350mm