

# Haas Workholding by Mitee-Bite Products



**Haas**  
F1 Team



## Uniforce Clamp Instructions

1. Mill a slot in fixture plate wider than dimension D.
2. Drill and tap per Technical Specs.
3. Insert steel slug into aluminum channel and tighten screw.

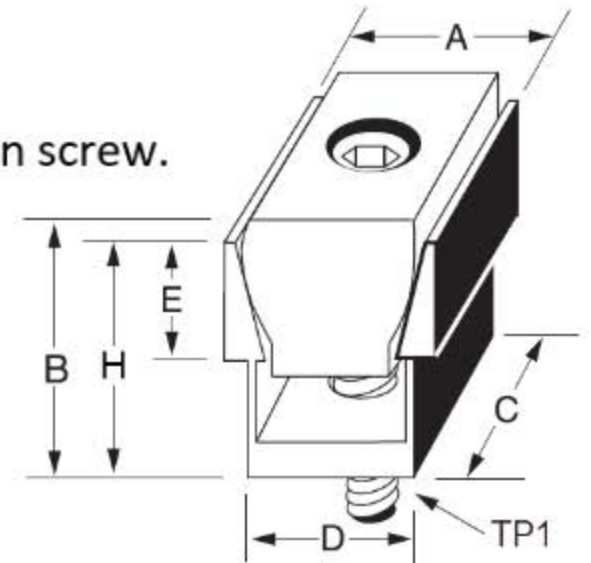
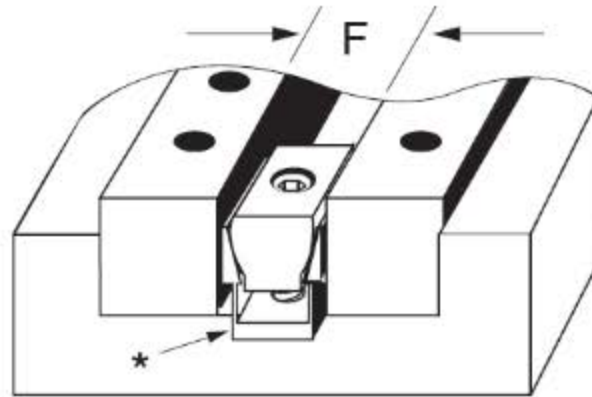

D\* - A milled slot wider than D dimension will ensure clamp remains in line with workpiece. Clamp sides should not come in contact with slot walls during expansion.

F\* - The distance needed between workpieces for clamp clearance. Drill and tap mounting hole on the center of F dimension.