

### TOTAL WEIGHT OF 09-0727:

- ABOUT 14.1 LBS [6.4 KG]

### THEORETICAL MAXIMUM PART WEIGHT:

- ABOUT 18.9 LBS [8.6 KG]

### ROUND STOCK

- MINIMUM PART DIAMETER:  $\varnothing$  2.25 in [57.17 mm]\*
- MAXIMUM PART DIAMETER:  $\varnothing$  9.07 in [230.57 mm]\*

### SQUARE STOCK

- MINIMUM PART WIDTH: 0.43 in [10.87 mm]\*
- MAXIMUM PART WIDTH: 8.54 in [217.05 mm]\*

### STROKE:

- $\varnothing$  0.945 in [24.0 mm]

### HOLDING FORCE:

- 240.0 lbs [1068.0 N]

### PRESSURE RANGE:

- 43.5 - 101.5 PSI [0.3 - 0.7 MPa]

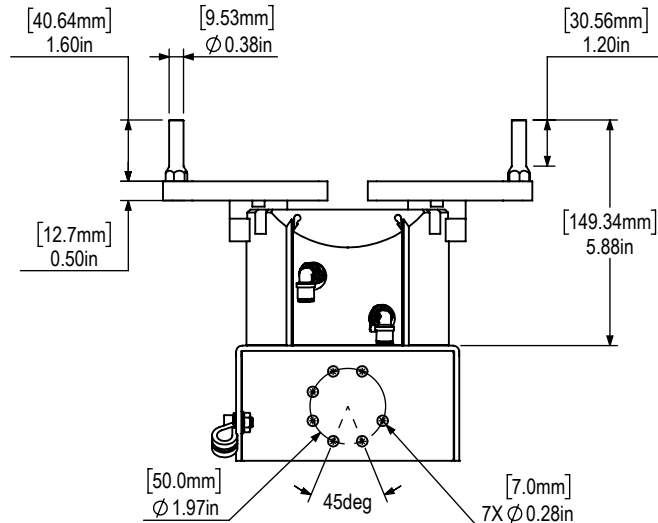

\*WEIGHT VARIES FOR EACH SET UP. TEST WEIGHT OF PART BEFORE USAGE.

\*SEE PAGE 3 FOR MORE INFORMATION ON MAX PART SIZE

## ROUND STOCK

GRIPPERS (INCH)		
Position	Min Ø	Max Ø
1	2.25	2.68
2	2.65	3.24
3	3.19	3.88
4	3.81	4.57
5	4.49	5.29
6	5.20	6.03
7	5.93	6.78
8	6.67	7.54
9	7.43	8.30
10	8.19	9.08

GRIPPERS (MM)		
Position	Min Ø	Max Ø
1	57.17	67.95
2	67.36	82.33
3	81.03	98.63
4	96.85	116.11
5	113.99	134.34
6	131.98	153.07
7	150.52	172.13
8	169.45	191.45
9	188.66	210.94
10	208.07	230.57

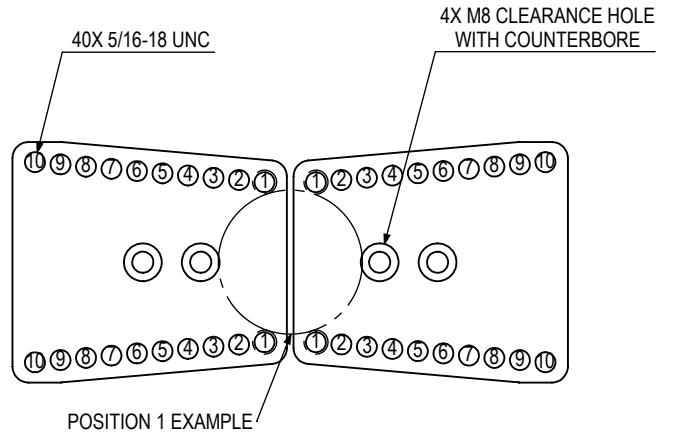

## SQUARE STOCK

GRIPPERS (INCH)		
Position	Min Ø	Max Ø
1	0.43	1.37
2	1.22	2.17
3	2.02	2.97
4	2.82	3.76
5	3.62	4.56
6	4.41	5.36
7	5.21	6.15
8	6.01	6.95
9	6.80	7.75
10	7.60	8.55

GRIPPERS (MM)		
Position	Min Ø	Max Ø
1	10.87	34.87
2	31.11	55.11
3	51.35	75.35
4	71.59	95.59
5	91.84	115.84
6	112.08	136.08
7	132.32	156.32
8	152.56	176.56
9	172.81	196.81
10	193.05	217.05

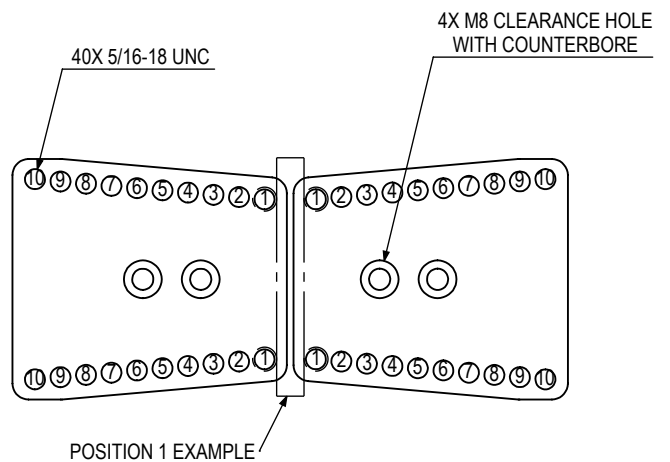

## ROUND STOCK MAX PART SIZE

"H" ≤	5.0 in [127.0 mm]
"D" ≤	6.0 in [152.3 mm]
Weight*	< 18.9 lbs [8.6 kg]

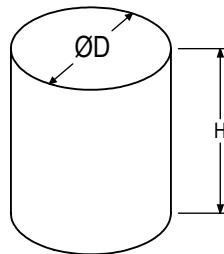

\*PART SIZE IS BASED ON THEORETICAL VALUES. TEST EACH PART BEFORE USAGE

\*WEIGHT CANNOT SURPASS SPECIFIED VALUE.

## SQUARE STOCK MAX PART SIZE

"L" ≤	4.0 in [101.6 mm]
"W" ≤	3.0 in [76.2 mm]
"H" ≤	4.0 in [101.6 mm]
WEIGHT*	< 18.9 lbs [8.6 kg]

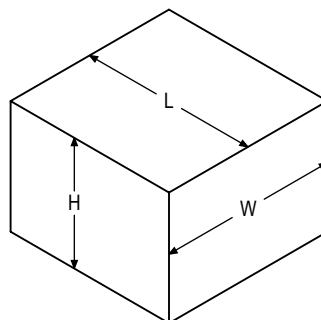

\*PART SIZE IS BASED ON THEORETICAL VALUES. TEST EACH PART BEFORE USAGE

\*WEIGHT CANNOT SURPASS SPECIFIED VALUE.