

STAGGARD CHIP BREAKERS
TYP. ALL FLUTES

DETAIL A
SCALE 8 : 1.25

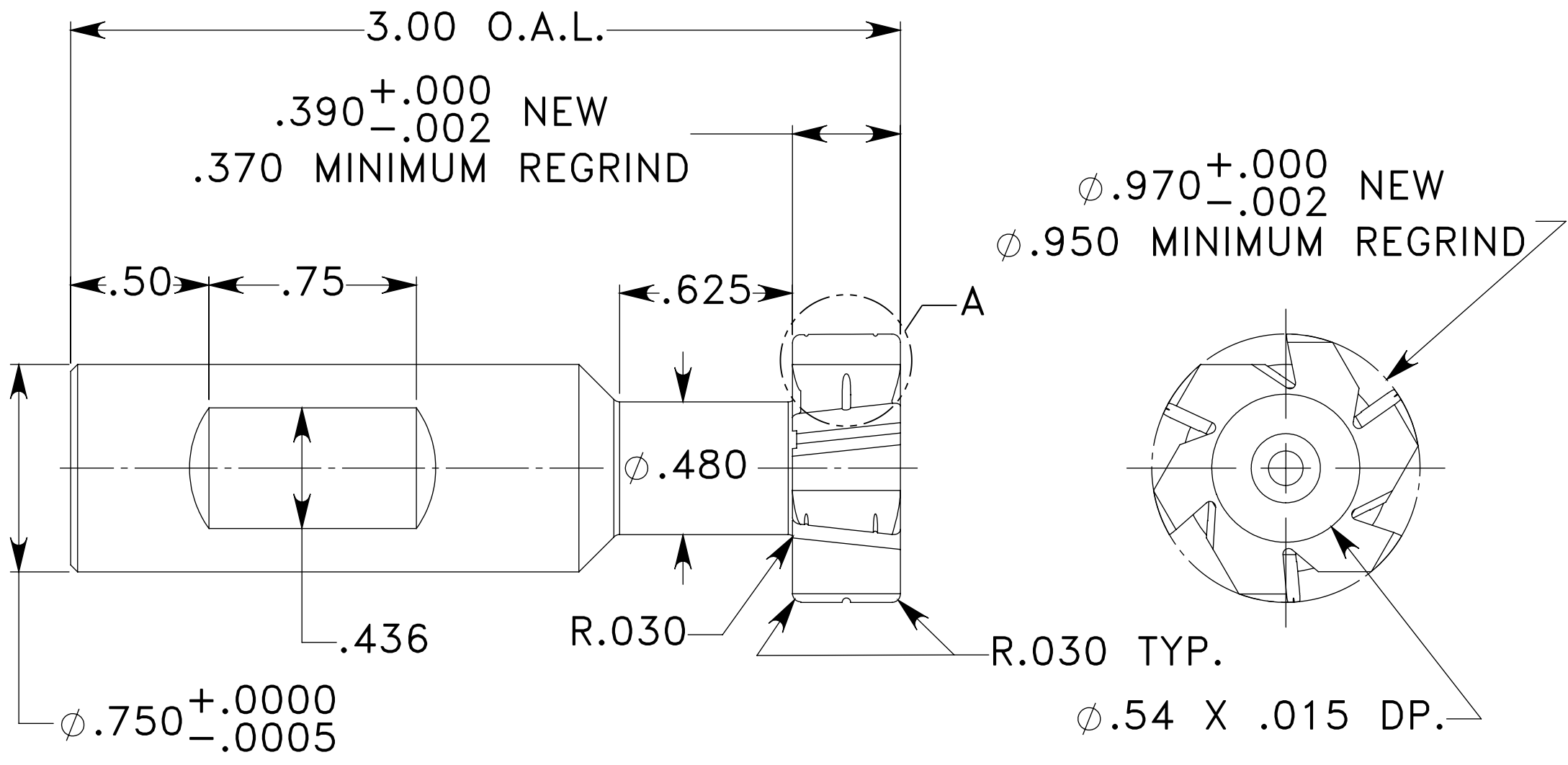
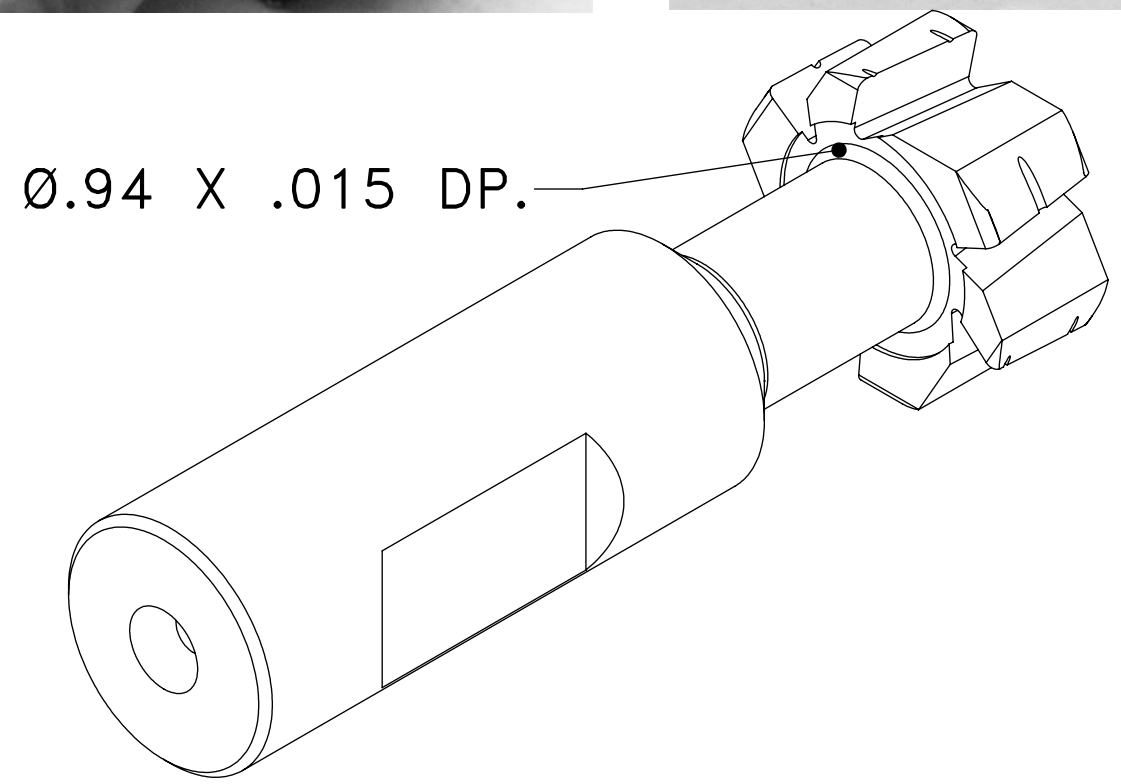

- NOTES: UNLESS OTHERWISE SPECIFIED
1. ETCH HAAS MATERIAL NUMBER ON THE TOOLS
 2. MAKE FROM: HANNITA PM 114018016
 3. MATERIAL: REX 76 W/6 TEETH
 4. COAT: TIALN
 5. SIDE CUTTING
 6. CUTTING GEOMETRY
 +7° AXIAL RAKE STAGGARD
 +3° RADIAL RAKE
 5 Prim. O.D.
 12° SECONDARY O.D.
 2 1/2° SIDE CLEARANCE
 2° FACE CONCAVITY
 7. MATERIAL TO MACHINE: CAST IRON
 8. TO BE USED ON: 20-0059, 20-4151
 9. WHEN REGRINDING, REMOVE THE MINIMUM AMOUNT OF MATERIAL IN-ORDER TO EXTEND THE LIFE OF THE TOOLS

SHEET 1 OF 1

Change Master 500000023884	Doc Number 10000104287	Doc Rev A	Doc Ver 01	Doc Status RL
Approved By: Date: 08/01/2018		HAAS AUTOMATION, INC.		
Material: NOTED		.970 X .390 T-SLOT CUTTER W/O COOLANT HOL		
Finish: NOTED		Material Number 99-56250		
<small>This document may contain copyrighted and proprietary information belonging to Haas Automation, Inc. No part of this document may be reproduced, copied, or transferred to a third party by any means - graphic, electronic, or mechanical, including photocopying, taping or information retrieval system - without prior written permission from Haas Automation, Inc.</small>		SIZE C	SCALE 1:1	Material Number 99-56250

A B C D E F G H J K L M N P R S T U V W