

Universal

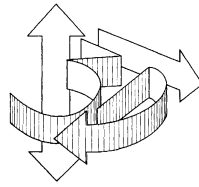

Sensor

Instruction for use

The Universal 3D-Sensor is a very precisioned and versatile measuring instrument for use on milling and erosion machines. With its help, milling spindles or electrode heads can be positioned quickly and exactly on the edges of the workpiece or fixture, the machine coordination system facilitated and lengths measured.

Technical data (view 1)

	with short sensor insert	with long sensor insert
Length L (without clamping shank)	113 mm 4.45 in.	153 mm 6.02 in.
Length L _S (clamping shank)	50 mm 1.97 in.	
Width B	65 mm / 2.56 in.	
Shank diam. D	20 mm / 0.787 in. (19.05 mm / ¾ in. if ordered)	
Weight	0.8 kg / 1.8 lb.	
Sensing ball diam. d	4 mm 0.1575 in.	8 mm 0.3150 in.
Measuring exactness		
radial	±0.01 mm ±0.0004 in.	±0.02 mm ±0.0008 in.
axial	±0.01 mm ±0.0004 in.	±0.01 mm ±0.0004 in.
Sensing depth T	25 mm 1 in.	65 mm 2.6 in.

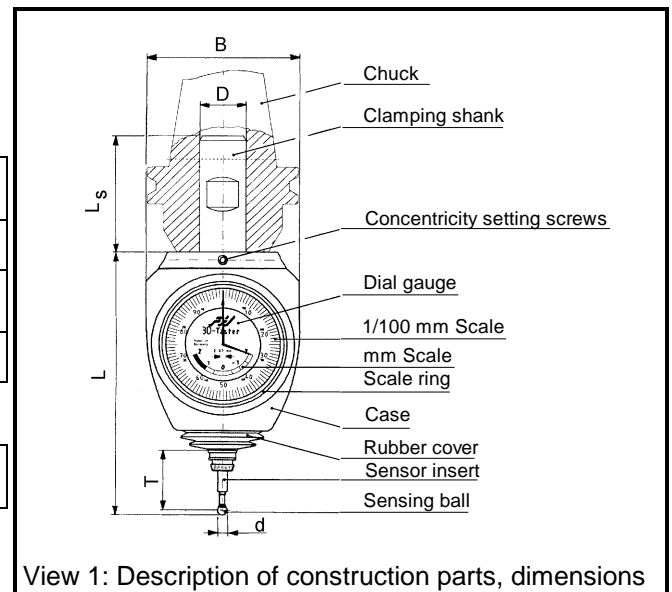

View 1: Description of construction parts, dimensions

Handling

1. Setting concentricity (view 2)

The concentricity must be set:

- after instrument has been clamped in a chuck.
 - after the sensor insert has been changed.
- The concentricity of the Universal 3D-Sensor is pre-set when assembled. But in order to make exact measurements, the concentricity must be readjusted again in the machine, where the measurements will be made. Only in this way errors in concentricity from the machine spindle and chuck can be optimally balanced.
- Clamp sensor in an according chuck (for ex.: Weldon shank, SK 40, ultrashort model, diam. 20 mm , order no. 40.305.20)
 - Clamp sensor with chuck in spindle or erosion head.
 - Place testing gauge with measuring plate against sensing ball and turn the spindle manually (The sensing ball may not thereby be driven out, view 2.1).
 - Loosen setting screws.
 - Set 0-point of testing gauge so that the indicator deflects the same in both directions (view 2.2).
 - Bring the indicator on the testing gauge to 0 through using the screws and enclosed key (view 2.3).
 - Turn the sensor each way at 90 degrees.

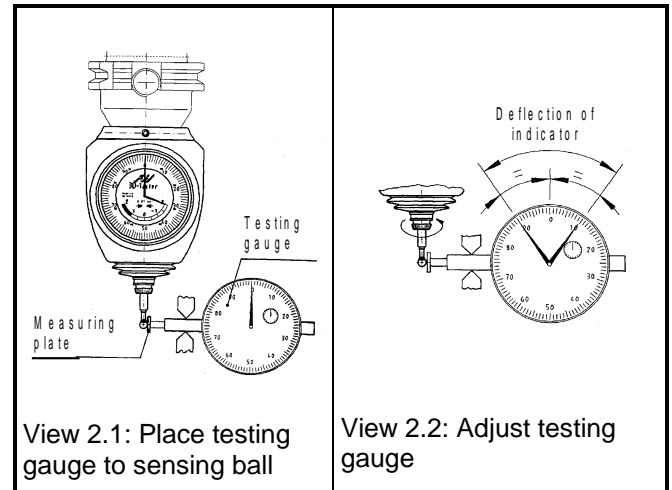

View 2.1: Place testing gauge to sensing ball

View 2.2: Adjust testing gauge

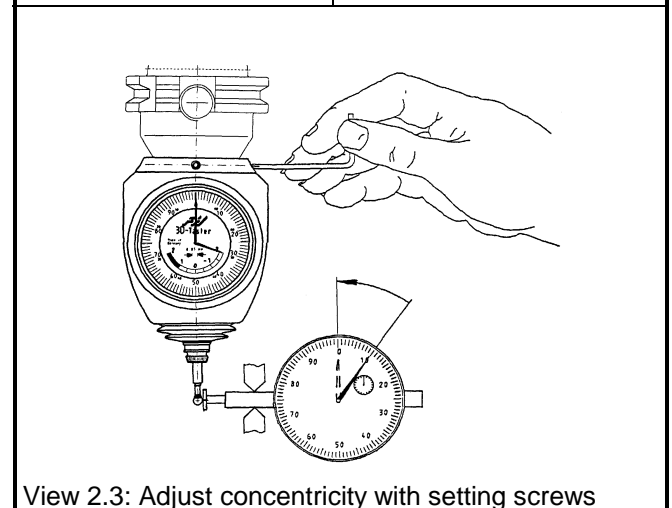

View 2.3: Adjust concentricity with setting screws

- Repeat each procedure until the indicator on the testing gauge remains still while turning and all screws are tightened.

2. Approaching radially (x, y axis, view 3)

- Clamp chuck with sensor in spindle or erosion head. It can be installed in any direction (horizontally or vertically).
- Check resting position of dial gauge. The long indicator of the dial gauge (1/100 scale) must show vertically to 0 while in resting position. Possibly turn the scale ring. Should this resting position change, return sensor for examination to manufacturer or distributor.
- Turn spindle so that the dial gauge is facing the operator. The turning angle doesn't matter. The sensor works in every direction.
- Slowly approach workpiece with sensing ball. The approaching motion must follow vertically to the workpiece surface. The sensing ball must not run along the edge of the workpiece (could lead to errors in measurements).
- During the approaching procedure do not twist the sensor (could lead to errors in measurements).
- As soon as the sensing ball has touched the workpiece, the spindle axis is 2 mm / 0.079 in. in front of the workpiece edge (when using the long sensor insert: 4 mm / 0.157 in.). From here on the distance between spindle axis and workpiece edge is indicated with correct sign (long sensor insert: double the measurement on the dial gauge; one unit = 0,02 mm / 0.00079 in.).
- When the dial gauge shows 0 (both indicators) the spindle axis is exactly over the edge of the workpiece. The machine axis can now be nulled without further calculation. Should the 0-point be overrun, set back and approach again.

Note:

The 0-point can be overrun without danger of damage up to 4 mm / 0.16 in. After this a ceramic bond in the sensor insert breaks and protects the workpiece as well as the sensing mechanism against damage. Only the sensor insert must then be replaced (see no. 6).

3. Approaching axially (z axis, view 4)

Height measurements can be executed in the axial direction. There is no difference here between short and long sensor insert.

- Approach the first surface until dial gauge is at 0 (as radial, views 4.1 and 4.2).
- Zero machine axis.
- Approach 2nd workpiece surface until dial gauge is at 0.
- Display on the machine (z-axis) shows height difference (view 4.3).

4. Measuring lengths

With the Universal 3D-Sensor workpieces can be measured in the machine, for example for controlling finished products.

- Approach first workpiece surface as under no. 2.
- Zero machine axis.
- Approach 2nd workpiece surface.
- Display on the machine shows distance in direction of axis.

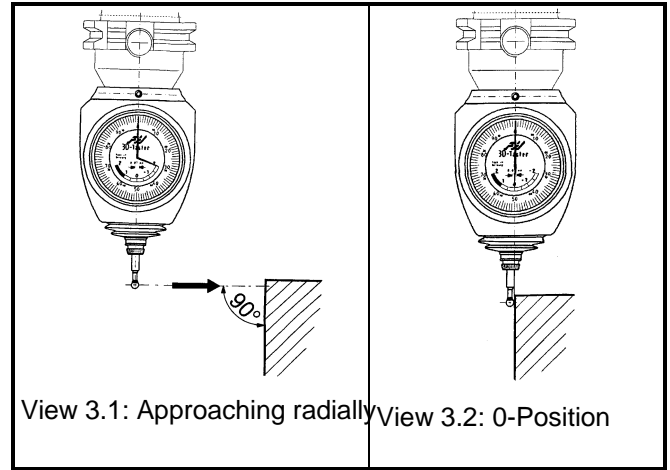

View 3.1: Approaching radially View 3.2: 0-Position

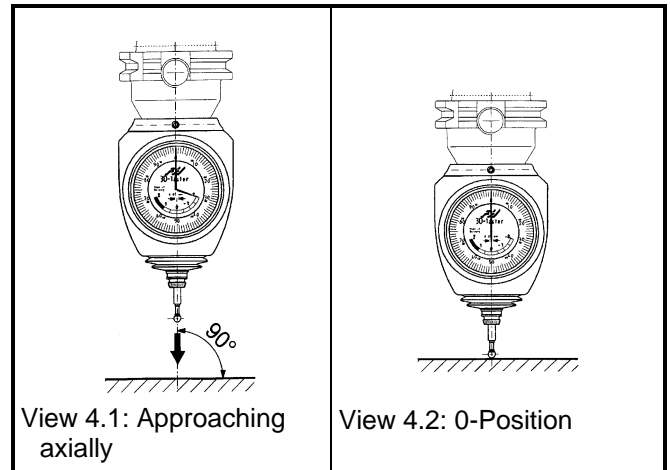

View 4.1: Approaching axially

View 4.2: 0-Position

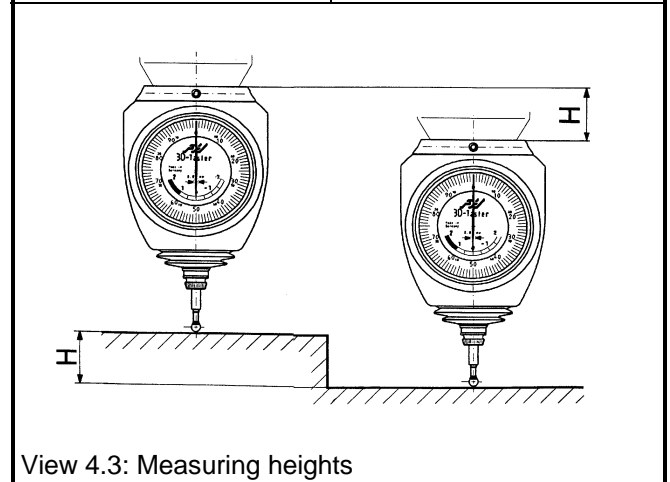

View 4.3: Measuring heights

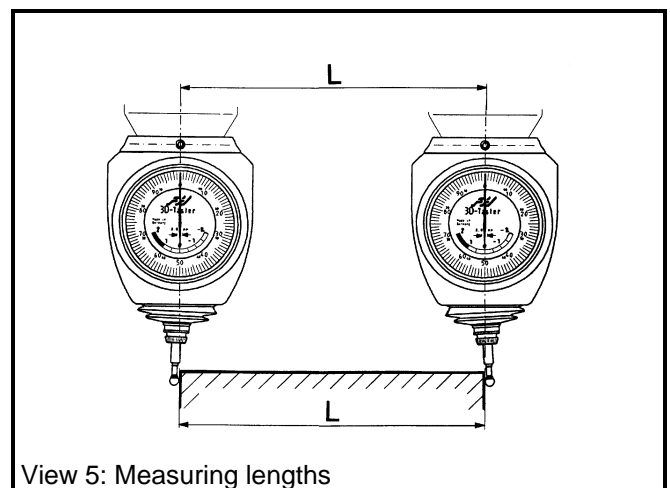

View 5: Measuring lengths

5. Centering and measuring drillings and shafts (x, y, axis, view 6)

- Drive route A-B (possibly in area of center) and halve.
- Drive route C-D, vertically to A-B, and halve: 1. center coordinate.
- Drive route E-F, parallel to A-B, and halve: 2nd center coordinate.

Drilling or shaft has now been centered and measured at the same time.

6. Replacing sensor insert

When using the long sensor insert or upon breakage, the sensor insert can be easily replaced.

- Unscrew old sensor insert by hand.
- Screw in new sensor insert (check for cleanness).
- Check rubber cover. The rubber cover protects the sensing mechanics against dirt. Please check that it sits properly (view 7).
- Check concentricity and if necessary reset (see no. 1).

7. General notes

- The Universal 3D-Sensor is maintenance free.
- During its use, the machine spindle must be still. Turn off any coolant.
- Should the sensor be opened, the guarantee expires.

8. Delivery contains:

- 1 Universal 3D-Sensor with short sensor insert
- 1 hexagon socket screw key size no. 2

9. Accessories

- Short sensor insert order no. 80.362
- Long sensor insert order no. 80.363

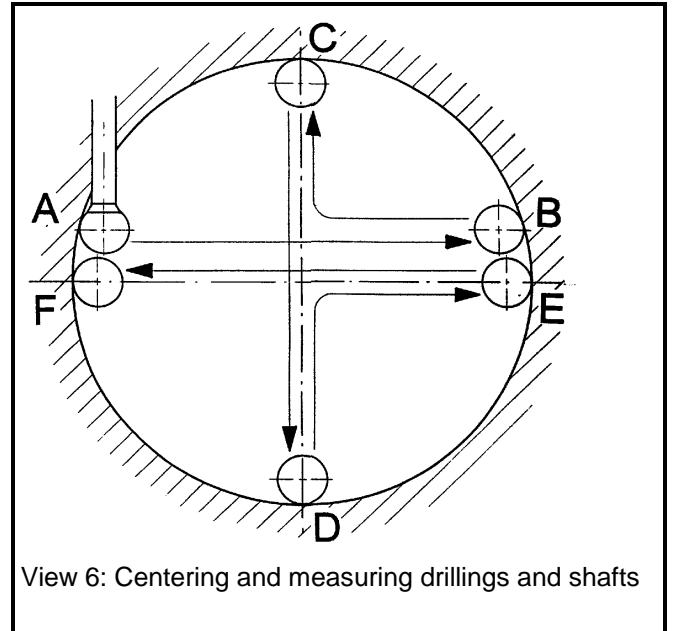

View 6: Centering and measuring drillings and shafts

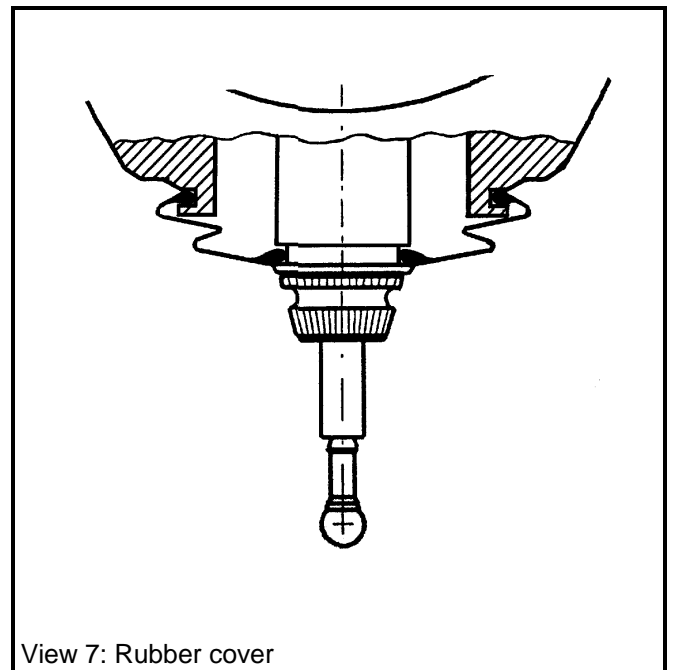

View 7: Rubber cover

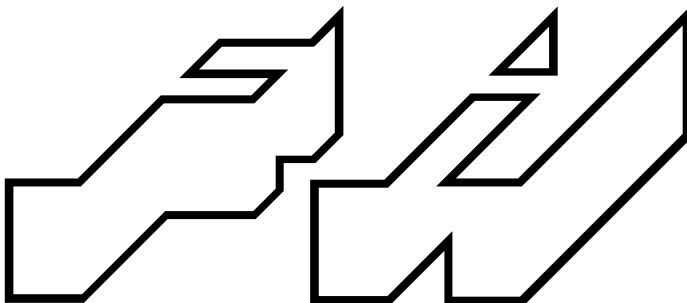

Haimer USA LLC
134 E. Hill Street
Villa Park, IL 60181
☎ 630-833-1500
Telefax (0 82 57) 18 50