



HAAS SERVICE AND OPERATOR MANUAL ARCHIVE

HA5C Series Operators Manual 96-4039J RevJ English June 2004

- This content is for illustrative purposes.
- Historic machine Service Manuals are posted here to provide information for Haas machine owners.
- Publications are intended for use only with machines built at the time of original publication.
- As machine designs change the content of these publications can become obsolete.
- You should not do mechanical or electrical machine repairs or service procedures unless you are qualified and knowledgeable about the processes.
- Only authorized personnel with the proper training and certification should do many repair procedures.

WARNING: Some mechanical and electrical service procedures can be extremely dangerous or life-threatening. Know your skill level and abilities.

All information herein is provided as a courtesy for Haas machine owners for reference and illustrative purposes only. Haas Automation cannot be held responsible for repairs you perform. Only those services and repairs that are provided by authorized Haas Factory Outlet distributors are guaranteed.

Only an authorized Haas Factory Outlet distributor should service or repair a Haas machine that is protected by the original factory warranty. Servicing by any other party automatically voids the factory warranty.



1. INTRODUCTION TO THE HAAS HA5C

1.1 DESCRIPTION

The HAAS HA5C digital indexing head is a fully automatic, programmable, rotary positioning device. The unit is made up of two parts: the mechanical head that holds the workpiece and the electronic unit that controls the rotation of the spindle. Positioning of the workpiece is accomplished by “programming” the angular movements into the memory of the control and then pushing the CYCLE START switch on the front panel.

The unit was specifically designed for rapid positioning of small parts in secondary operations such as milling, drilling, and tapping. The device is especially suited to automatic machines such as NC mills and automatic production machines. The control can be remotely activated by your equipment and does not require human assistance, resulting in fully automatic operation. Furthermore, one unit can be used on several different machines, thereby eliminating the need for multiple units.

SPINDLE

Positioning of the spindle is accomplished through a specially ground and heat treated, self-locking worm and worm gear. The worm is connected to a servo motor. You are no longer restricted to a 24 or 48 position indexing plate. Odd number bolt circles and uneven hole spacing are easily handled with simple programming.

CONTROL

The control can be programmed to rotate the spindle in either direction (clockwise or counter-clockwise) with step sizes from .001 to 999.999 degrees. There can be 99 different steps stored in memory. Additionally, each step can be repeated (or looped) up to 999 times. The memory in the controller is non-volatile so that your program is retained even when the power is turned off. You may store seven separate programs (Prog 0- Prog 6).

The spindle can be programmed to rotate at a feed rate of .001 degree per second up to 270 degrees per second (for rapid positioning). A ZERO RETURN function, which returns the spindle to its original starting position, can be either programmed or manually activated.

The optional RS-232 interface can be used to upload, download, enter data, read position, start, and stop motor operation.

1.2 SELF LOCKING - DEFINITION

Good machining practice dictates rigidly held parts and setups. The Model HA5C is engineered to provide this in three ways. Locking is provided by the close tolerance worm and worm gear, the large bearing area between spindle and body, and the servo motor. The worm gear is considered to be self locking because while the worm can drive the worm gear the reverse is not true. The principle here is the same as if you tried to turn the handle on your milling machine by trying to push the table. The locking motion is further guaranteed by the servo motor that prevents any small movements of the worm by being electronically stopped. Even the heaviest of cuts that would destroy the indexing head would not be able to cause the spindle to rotate.



1.3 MACHINABLE PART SIZE

The Model HA5C was designed for indexing small parts that normally fit in standard 5C collets, step collets, and small fixtures. Parts two inches in diameter and under made of common alloys can be machined easily without undue concern. Larger parts may require special fixtures or chucks and consideration should be given to the weight of the part and fixture and the rate of material removal. The HA5C can be used on milling machines, CNC machines, EDM's, broaching machines, and just about anything that needs to index a part. It can be used in both the vertical and horizontal positions. It can be used as a slave to your CNC machine or the master control unit in dedicated drilling operations.

Generally you will have to use your own judgment what size part you can successfully machine on the HA5C. We have seen enormous parts machined but they also required a reduction in metal removal rates to accomplish it. If you are familiar with a typical indexing head, here is a good rule of thumb to use: if you can do the job on the manual head, the HA5C can do it without a problem.

1.4 FEATURES

RIGID DESIGN

Large bearing surfaces support heavy cutting forces on large or small parts.

HARDENED AND GROUND SPINDLE

For higher accuracy.

ALUMINUM BRONZE WORM GEAR

For longer life.

HARDENED AND GROUND WORM

Made from 8620 Chromium-Nickel-Molybdenum steel.

AC SERVO DRIVE

Closed loop, $\frac{3}{4}$ HP AC servo motor brushless, (or a $\frac{1}{2}$ HP DC servo motor brush).

VARIABLE FEED RATES

Variable from .001 deg./sec. to 270 deg./sec.

RESOLUTION

Standard resolution of .001 degrees.

PROGRAMMING

Absolute or incremental programming. Up to 99 different steps can be stored in memory, and each step can be looped 999 more times. The ease and flexibility of programming the Haas control enables a single unit to serve you in many ways.

SIMPLE EDITING

Edit a program by simply writing over existing steps, or inserting or deleting a line (or several lines) between steps, with automatic program line re-numbering.

SUBROUTINES

Allows you to repeat sequences up to 999 times saving programming time and memory space.

AUTOMATIC CIRCLE DIVISION

You can program a step that automatically divides a circle into any number of equal parts (between 2 and 999).

PROGRAMMABLE PARAMETERS

You can alter many of the basic features by performing your own basic programming.



PROGRAM STORAGE

Store and recall from up to seven different programs.

MEMORY

A non-volatile memory retains your program even when power is turned off. It also remembers the current spindle position and step number.

INTERFACING

Most CNC mills can be interfaced with the HA5C quickly and easily by using a spare **M** function which provides a switch-closer as a signal between your mill and the HA5C.

EMERGENCY STOP/FEED-HOLD

You can use the EMERGENCY STOP to feed-hold spindle movement without losing position on restart.

ZERO RETURN

An “automatic home” position returns the spindle to its original starting position from any point.

LINEAR & SPIRAL MILLING

For semi fourth-axis capability.

FAST SET-UPS

All connectors are “quick-disconnect”, ensuring fast and easy set-ups.

STANDARD POWER

Operates on 115V AC +/-5% @ 15 Amps.

RS-232 INTERFACE

For computer control of sending and receiving programs.

12-MONTH WARRANTY

Against any defects in materials or workmanship.

REPLACEABLE COLLET KEY

A broken collet key can be easily replaced through the access hole in the front of the casting.



1.5 SPECIFICATIONS

SPINDLE

Height	4.000 ± 0.001 from spindle center to base
Torque	60ft.-lb. brushless, 20 ft-lb. HA5CSB (45 ft.-lb., brush)
Runout	0.0004 T.I.R.
Backlash	40 arc seconds
Speed	Feed rate selectable from .001deg/sec to 330 deg/sec. For HA5CSB: .001 deg/sec to 800 deg/sec. (.001 deg/sec to 270 deg/sec, brush type)
Nose Thread	2 3/16 - 10
Collets	Standard 5C

INDEXING

Indexing Accuracy	+/- 30 seconds in one direction
Repeatability	Within 10 arc seconds
Resolution	0.001 degrees

MOTOR

Horsepower	$\frac{3}{4}$ HP AC servo motor brushless ($\frac{1}{2}$ H.P. DC servo motor, brush)
Gear Ratio	60:1 self locking worm gear (33:1 HA5CSB)

OPERATING SPECIFICATIONS

Power Requirements	120V AC +/- 5 percent @ 15 amps
Oil Requirements	Mobil SHC 630 (synthetic)

GENERAL REQUIREMENTS

Operating Temperature Range	41°F to 104°F (5 to 40°C)
Storage Temperature Range	-4°F to 158°F (-20 to 70°C)
Ambient Humidity:	20% – 95% relative humidity, non-condensing
Altitude:	0-7000 ft.



1.6 MACHINE DIMENSIONS

HA5C- Single Spindle

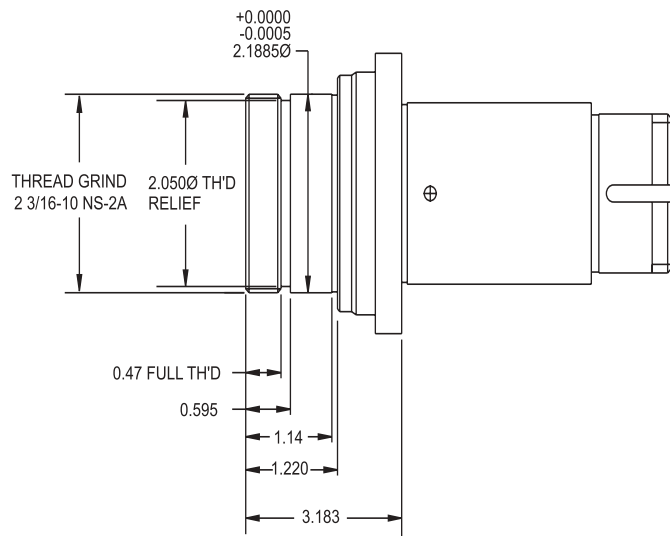
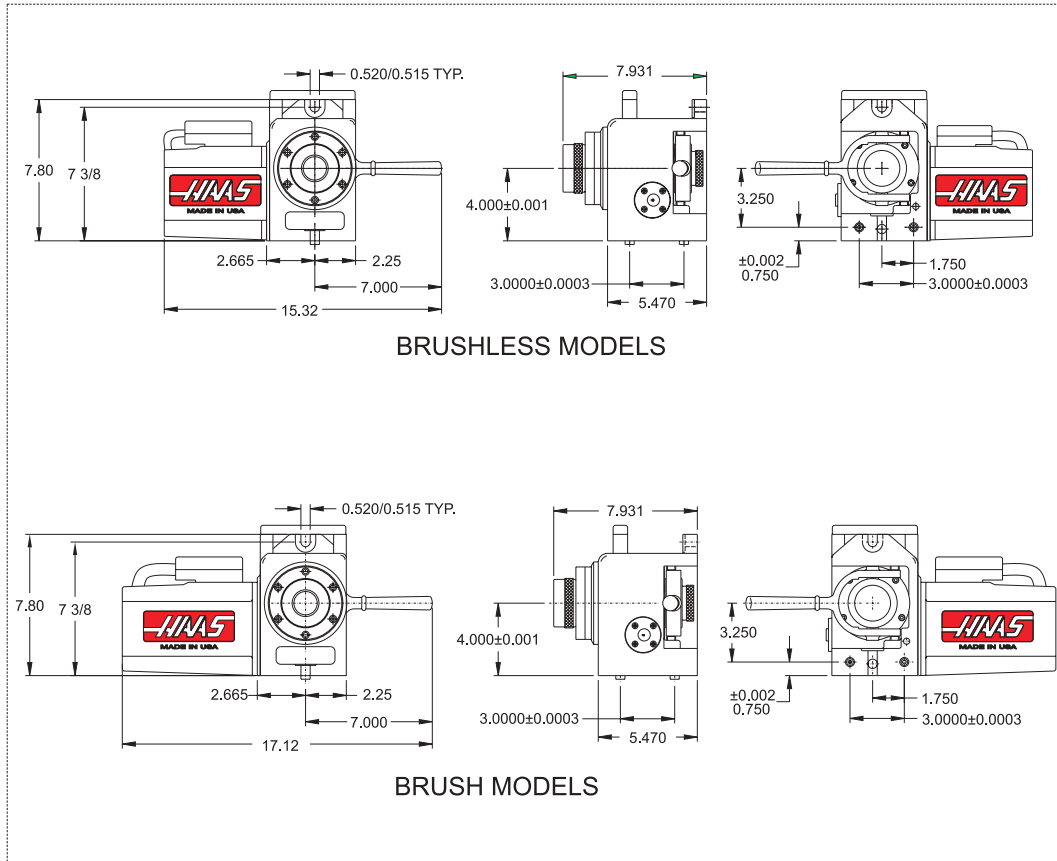

SPINDLE NOSE DIMENSIONS



HA5C2,3,and 4

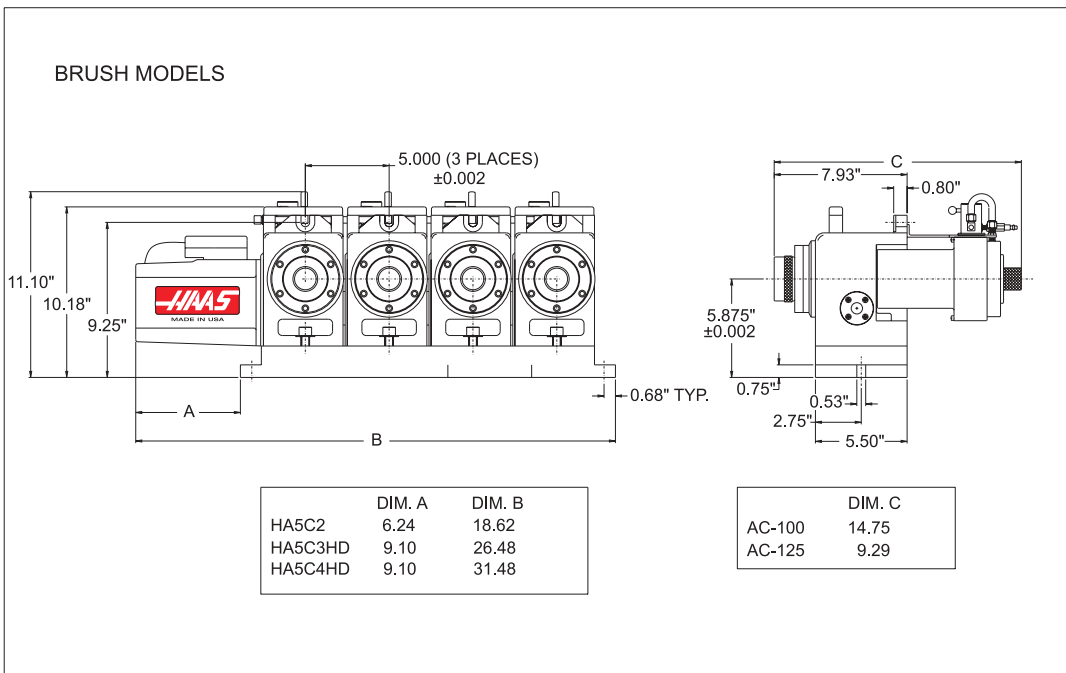
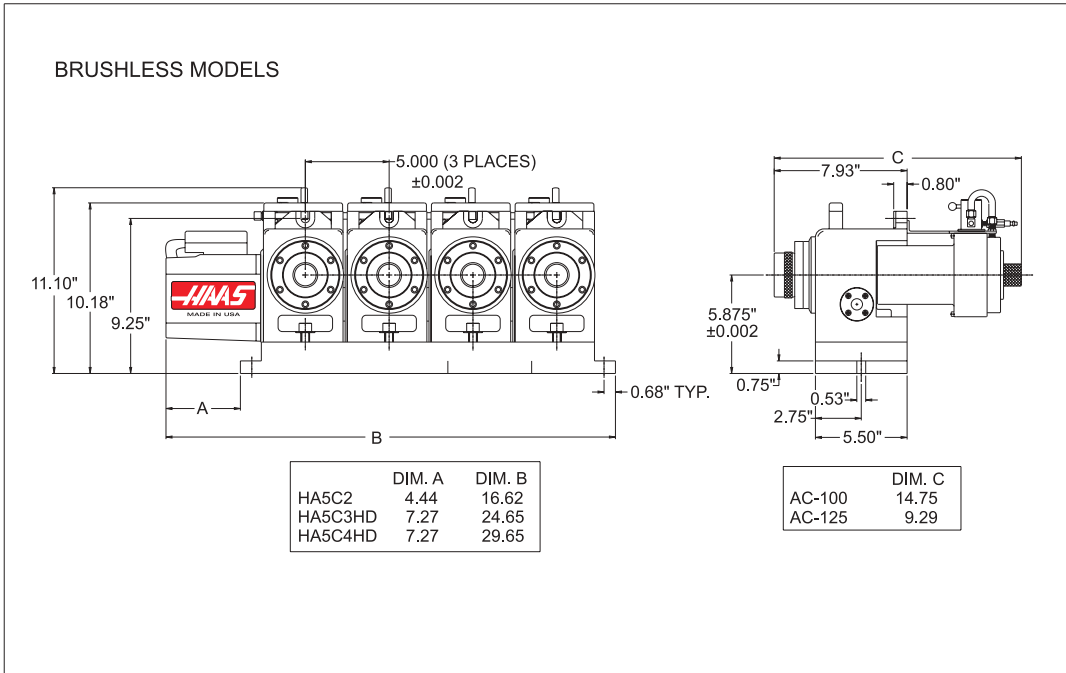



1.7 OPTIONAL SERVO CONTROL BRACKET

Designed to work specifically with the Haas line of CNC mills. This bracket keeps the Servo Control in easy reach of the operator. Allowing for easy joint programming between the Haas mill and Rotary table. Contact your Haas dealer to order. (Haas part number: SCPB)

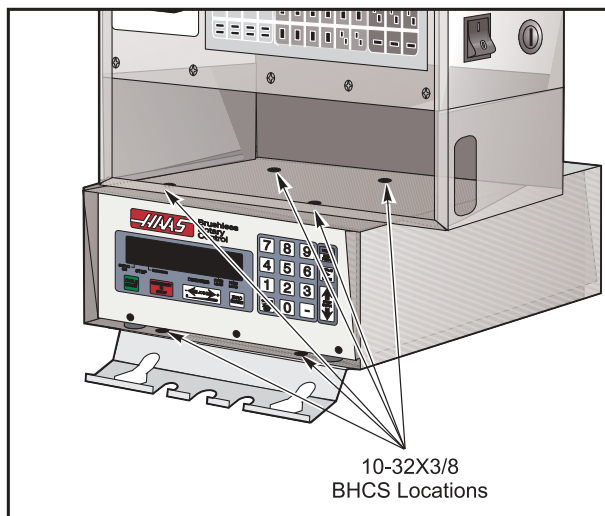

Installed Servo Control Bracket

1.8 HAAS TAILSTOCKS

Tailstocks must be properly aligned to the rotary table before using.

Clean bottom surface of tailstock casting before mounting to mill table. If there are any noticeable burrs or nicks on the mounting surface, clean them with a deburring stone.

See the Haas tailstock manual (96-5000) for pneumatic tailstock's operating pressure.

When using Servo 5c Indexers, Haas Automation recommends using LIVE CENTERS ONLY!



2. SETTING UP THE INDEXING HEAD AND CONTROL

2.1 GENERAL SETUP

1. Fill out your warranty card and mail it in. (Very Important).
2. Place the indexer on your machine. Route the cable from the head such that it avoids tool changers and table edges. Cable slack must be provided for your machine's movements. If the cable is cut, the motor will fail prematurely; replace a damaged cable immediately. Secure your HA5C Indexer to your machine's T-Slot table as shown below:

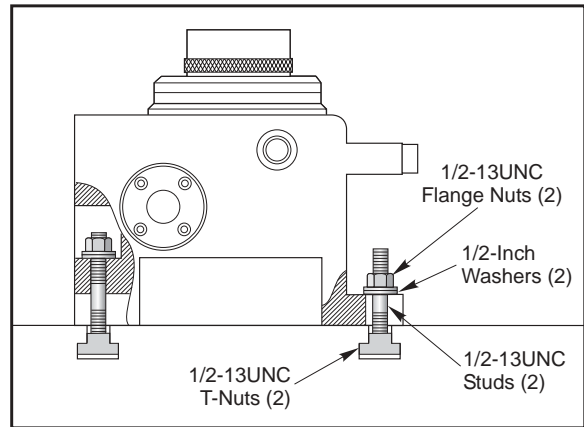
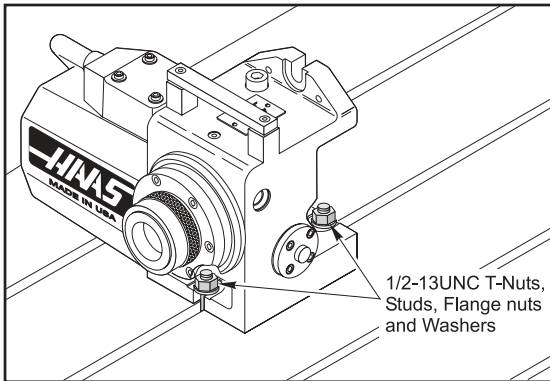

3. Place the indexer in an area free from chips and coolant where air can circulate freely. Do not let chips pile up over the motor enclosure, as this would prevent proper cooling.

CAUTION: Never connect or disconnect this cable with the power on; instant failure will result.

4. Connect the indexer to run as a full-fourth or semi-fourth axis. See the following figure. For full-fourth axis, the indexer is connected directly to the Haas mill control at the connector labeled "4th axis", and is the desired connection.

Note: The HAAS mill must have the 4th axis option to run full-fourth axis and must be configured as brush or brushless axis to be compatible with your indexer. Brushless axis uses two cables and two connectors at the 4th axis port. Brush axis uses one cable and one connection at the 4th axis port on the control.

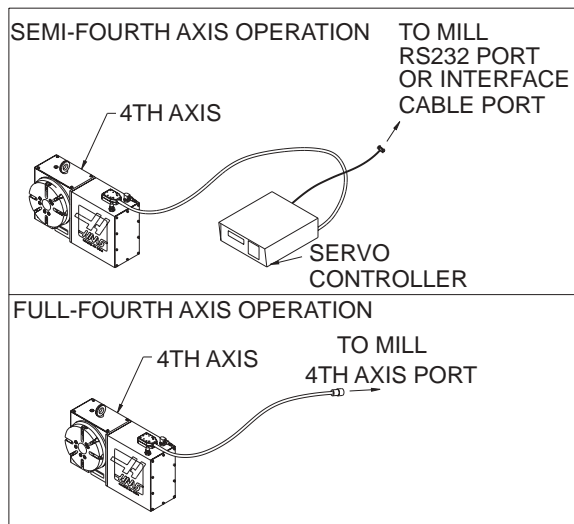

5. Route the cable over the back of the mill sheetmetal and install the cable clamp. The bottom plate of the clamp assembly must be removed and discarded before installing the clamp to the mill. Assemble the clamp to the mill as shown.

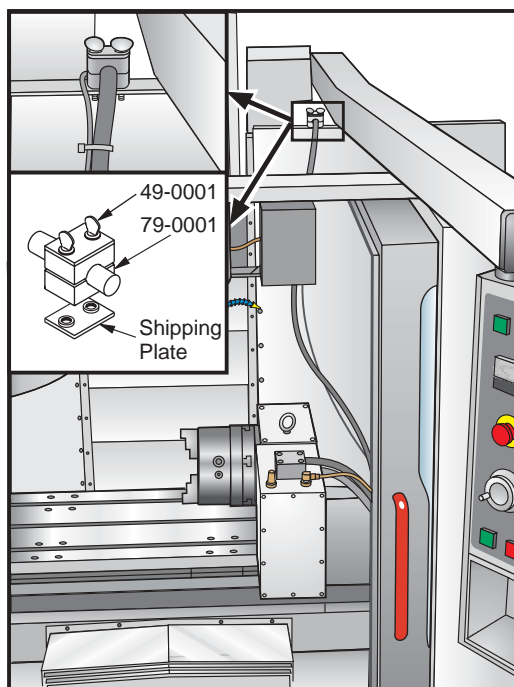

6. If adding an indexer to a Haas mill the settings must be set for the specific unit. Refer to the instructions in the mill manual or call the Haas service department.
7. **Semi-Fourth Axis:** Secure the servo control in servo pendant bracket (Haas part number SCPB) as seen at the end of the introduction section. Do not cover any surface of the control as it will quickly overheat. Do not place the unit on top of other hot electronic controls.



8. Connect the large black cable from the indexer to the controller.

CAUTION: Never connect or disconnect this cable with the power on! Instant failure will result!

9. **Semi-Fourth Axis:** Connect the AC line cord to a 120V AC grounded receptacle. The cord is a three-wire ground type, and the ground must be connected. Power is 120VAC. The power service must supply a minimum of 15 amps continuously. Conduit wire must be 12 gauge or larger and fused for at least 20 amps. If an extension cord is to be used, use a three-wire ground type and the ground line must be connected. Avoid outlets that have large electric motors connected to them. Use only heavy duty 12 gauge extension cords capable of 20 amp load. Do not exceed a length of 30 feet.
10. **Semi-Fourth Axis:** Connect the remote interface lines. See "Interfacing to Other equipment" section.
11. Check the oil level. If it is low, add oil. Use MOBIL SHC-630 synthetic gear oil (Viscosity Grade ISO 220). For the HRT210SHS use Mobil SHC-626 synthetic gear oil (Viscosity Grade ISO 68).
12. Save the packing materials in case you need to ship the unit.
13. At the end of the workday or shift, it is important to clean the rotary indexer. The indexer should be free of any chips or grime. Clean with a chip brush and apply a coat of a rust preventative.

CAUTION! Do not use air gun around front or rear seals. Chips may damage seal if blown in with an airgun.

14. Turn on the mill (and servo control, if applicable) and home the indexer by pressing the zero return button. All Haas indexers home in the clockwise direction as viewed from the spindle.



2.2 INTERFACING TO OTHER EQUIPMENT

Interfacing is an unfriendly word that inspires fear in most non-electrical people. In reality, you are interfacing objects all the time. Hooking up a stereo, computer, or VCR requires many connections, or interfaces. Plugging a lamp into the wall and turning the switch on is really interfacing a 100 watt incandescent lamp up to a 15 Megawatt generating plant. While there are hundreds of connections between your lamp and the power company, it is really a simple process. The HAAS controls are just as simple.

The control can be installed to communicate with your mill two different ways: RS-232 Interface or CNC Interface Cable. These connections are detailed in the following sections.

Semi-Fourth Axis Operation

The HAAS control has two signals: one input and one output. Your equipment tells the HAAS control to index (an input), it indexes, and then sends a signal back to your equipment that the index (an output) has been completed. These signals are simply switch closures, or in mechanical terms, relays. A switch (relay) is closed inside your machine that tells us to index, we index and then close a switch (relay) inside our control to tell your machine that we are done. This interface requires four wires; two for each signal. They are from the remote input on the back of the HAAS control and from your equipment or CNC (**C**omputer **N**umerically **C**ontrolled) machine.

2.3 THE RELAY IN THE HAAS CONTROL

The relay inside the Model HA5C has a maximum rating of 2 amps at 30 volts D.C./ 120V AC. It is programmed as either a normally closed or a normally open relay, closed during cycle or after cycle (see Parameters). It is intended to drive other logic or small relays. It will not drive other motors, magnetic starters, or loads exceeding 100 watts. If you use the feedback relay to drive another D.C. relay (or any inductive load), remember to install a snubber diode across your relay's coil in the opposite direction of coil current flow. Failure to use this diode or other arc suppression circuitry on inductive loads, no matter how small they may be, will result in the contacts of the relay arcing together in a very short time.

To test the relay, use an ohmmeter to measure the resistance across pins 1 and 2. With the control off, the reading should be infinite. If a lower resistance is measured, the contact points have failed and the relay must be replaced. Radio Shack sells a relay that can be used as a replacement (Cat. #275-241) but it should only be replaced by a qualified technician.

Automatic Drilling Applications

A common application for the HA5C head is in dedicated drilling operations where the controller is the master unit. This utilizes the **remote input**. The cycle start lines are connected to a micro switch that closes when the drilling head retracts and the finish lines are connected to the start lines of the drilling head. Here the operator pushes the CYCLE START on the controller to start the cycle. The HA5C indexes, and when in position, the feedback relay closure is used to trigger the drilling head to drill the hole. The micro switch mounted on the top of the drilling head will then trigger the HA5C to index when the drilling unit retracts.

This results in an endless loop of the HA5C triggering the drill unit and the drill unit triggering the HA5C. In order to break the cycle, a **G** code of 97 is inserted in the last step of the HA5C control. The **G** code 97 is a **No Op** code that tells the control not to send the feedback relay closure so the cycle can be stopped.



2.4 THE REMOTE INPUT

The CNC Interface Cable provides a basic method of communication between a non-Haas mill and Haas Servo Control/Rotary Head. Since most CNC machine tools are equipped with spare M-codes, Semi-fourth axis machining can be achieved by connecting one end of the CNC Interface Cable to any one of these spare relays (switches), and the other to a Haas Servo Control unit. Indexing commands for the rotary unit are stored only in the Servo Control's memory, and each pulse of the host machine's relay triggers the control to index to its next programmed position. After finishing the index, the Servo Control signals that it has finished and is ready for the next pulse.

A remote socket is provided on the back panel of the control unit. The remote input consists of a cycle start line and a cycle finish line. To connect to the remote, you will need a connector, supplied by us or obtained from a local source, that can be used to trigger the controller from any one of several sources.

The cable connector used is a male four-pin DIN connector. The Haas Automation part number is 74-1510 (Amphenol part number is 703-91-T-3300-1). The Haas Automation part number is 74-1509 for the panel receptacle in the control box is (Amphenol part number 703-91-T-3303-9).

Cycle Start

Figure 4 shows the connector as viewed while looking at the rear panel of the control unit. When pins 3 and 4 are connected together, the control will index the head one cycle or step. Pins 3 and 4 must be connected for a minimum of 0.1 seconds. To index again, pins 3 and 4 must be opened for a minimum of 0.1 seconds. Under no circumstances should power be applied to pins 3 and 4. A relay closure is the safest way to interface the control to your equipment.

The following explains the electrical details of how a cycle start is implemented: Pin 3 supplies a positive 12 volts at 20 milliamps and pin 4 is connected to the diode of an opto-isolator that grounds to chassis. Connecting pin 3 to pin 4 causes a current to flow through the diode of the opto-isolator triggering the control.

If the control is used around high frequency equipment such as electric welders or induction heaters, you will need to use shielded wire to prevent false triggering by radiated EMI (electromagnetic interference). The shield should be attached to earth ground.

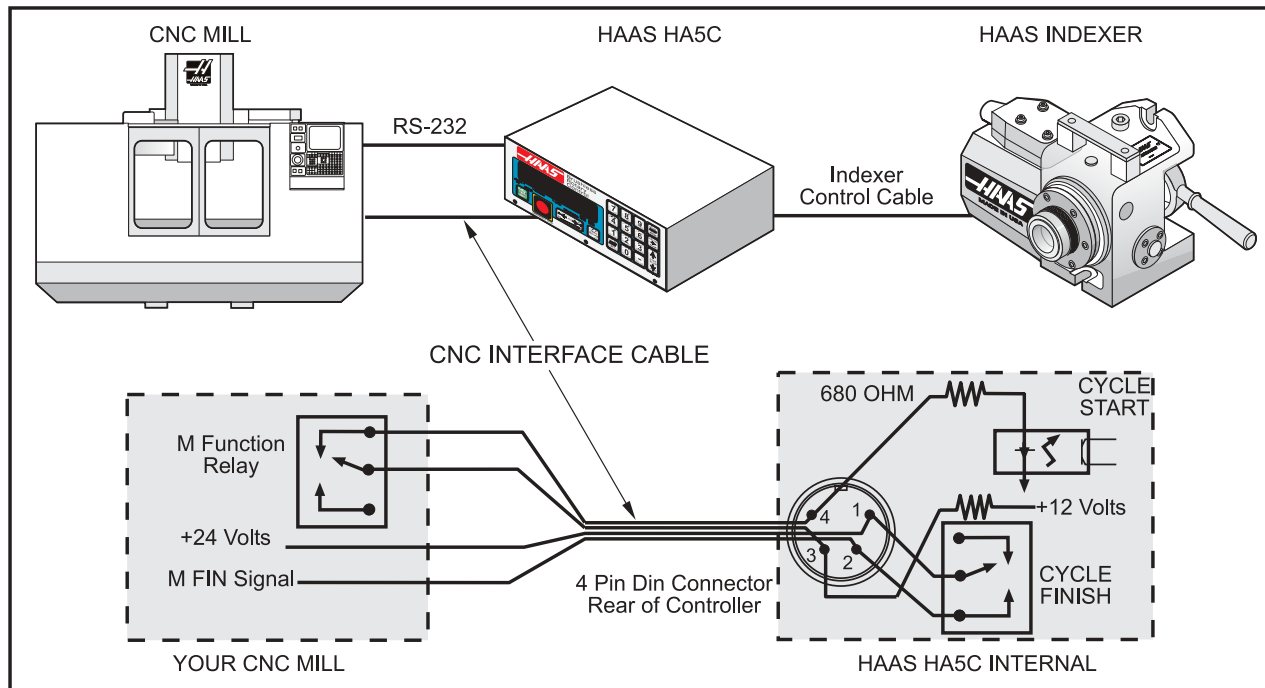
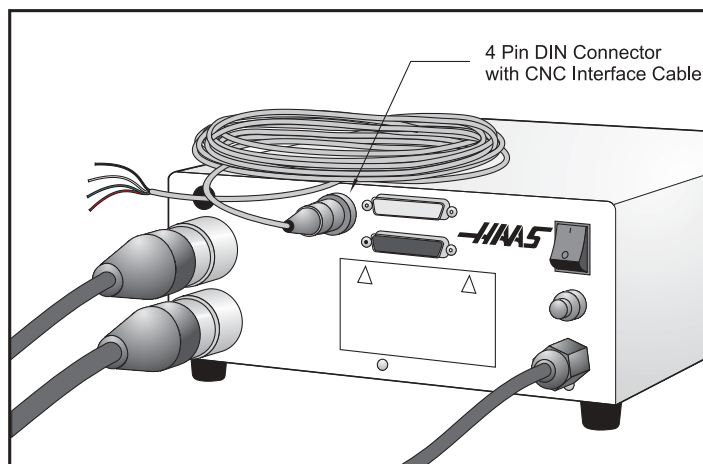

Figure 4. A typical CNC interface.

Cycle Finish

If your application is in an automatic machine, such as a CNC mill, the feedback lines (pins one and two) should be utilized. Pins one and two are connected to the contacts of a relay inside the control and have no polarity or power on them. They are used to synchronize the automatic equipment with the controller. The feedback lines provide a switch closure through a relay inside the Haas control box to let the machine know when the HA5C has finished indexing. The relay can be used to FEED HOLD NC machine movements or it can be used to cancel the **M** function.

If your machine is not equipped with such an option, another alternative may be to dwell for a period of time longer than it takes the control to index the head. The relay will trigger for all cycle start closures except a no-operation code 97.





2.5 REMOTE OPERATION WITH MANUAL EQUIPMENT

The remote connection is used when you wish to index the unit other than by the START switch on the front panel. This frees the operator from having to touch the control to start indexing. For example, using our optional **remote quill switch** (Part# RQS) for Bridgeport milling machines, every time the quill handle is retracted it touches a micro switch on the clamp, the indexing head will rotate automatically, thereby eliminating the need to remove your hand from the quill. Production is increased dramatically using this time saving procedure. Using a magnetic base, an aluminum bracket, and a micro-switch you can get the unit to index almost anywhere you wish. Use the switch to index the unit when you are milling. Every time the table comes back to a certain position, a simple bolt on the table can close the switch, thereby indexing the unit.

Refer to Figure 4. By simply connecting pins 3 and 4 together, the control will index. Be careful that you do not apply power to these lines (3 and 4 only). You do not need to hook up the feedback pins 1 and 2 unless you want the control to start another mechanism such as an automatic drilling head. The feedback pins (1 and 2) do not need to be connected for the control to operate.

Color-coded remote interface cables are available as an option to help the users understand the M-function hookup, and are coded as follows:

1 = red	3 = black
2 = green	4 = white

2.6 REMOTE OPERATION WITH CNC EQUIPMENT

NOTE: All Haas controls come standard with 1 CNC interface cable. Additional CNC interface cables can be ordered (Haas P/N CNC).

CNC machines have Miscellaneous functions called **M** functions. These control external switches (relays) that turn things on or off (i.e., spindle, coolant, etc.,). Most CNC controls provide some degree of access to the **M** functions with most late model machines providing several spare relays just for this purpose. Our remote cycle start line is hooked into the normally open contacts of a spare **M** function relay. The remote feedback lines are then connected to the **M** function finished line (MFIN) which is an input to the CNC control to cancel the **M** function and proceed onto the next block of information.

On late model CNC machines, interfacing the unit is relatively simple if you know where to make the connections. Your machinery dealer is the best source for this information.



2.7 THE RS-232 INTERFACE

There are two connectors used for the RS-232 interface. They are both DB-25 connectors, one male and one female. Multiple controllers are connected by daisy-chaining the boxes. The cable from the computer connects to the female connector. Another cable can connect the first box to the second by connecting the male connector of the first box to the female connector of the second. This can be repeated for up to nine controllers.

Since the RS-232 connector on the back of most PC's is a male DB-9, only one type of cable is required for connection to the controller, or between controllers. This cable must be a DB-25 male on one end and a DB-9 female on the other. Pins 1, 2, 3, 4, 5, 6, 7, 8, and 9 must be wired one-to-one. It cannot be a Null Modem cable, which inverts pins 2 and 3. To check cable type, use a cable tester to check that communication lines are correct. The controller is DCE (Data Communication Equipment). This means that it transmits on the RXD line (pin 3) and receives on the TXD line (pin 2). The RS-232 connector on most PC's is wired for DTE (Data Terminal Equipment), so no special jumpers should be required.

The Down Line (RS-232 out) DB-25 connector is only used when more than one controller is to be used. The first controller's down (RS-232 out) line connector goes to the second controller's up (RS-232 in) line connector, etc.

The RS-232 interface sends and receives **seven data bits, even parity, and two stop bits**. The data rate can be between 110 and 19200 bits per second. When using RS-232, it is important to make sure that Parameters 26 (RS-232 Speed) and 33 (X-on/X-off Enable) are set to the same value in the controller and PC. Parameter 12 must be set to 3 in order to coordinate mill and controller motion. This will prevent Aux. axis position mismatch alarm (355) when in handle jog mode.

If Parameter 33 is set to **on**, the controller uses X-on and X-off codes to control reception, so be sure your computer is able to process these. It also drops CTS (pin 5) at the same time it sends X-off and restores CTS when it sends X-on. The RTS line (pin 4) can be used to start/stop transmission by the controller or the X-on/X-off codes can be used. The DSR line (pin 6) is activated at power-on of the controller and the DTR line (pin 20 from the PC) is not used. If Parameter 33 is 0, the CTS line can still be used to synchronize output.

When more than one HAAS controller is daisy-chained, data sent from the PC goes to all of the controllers at the same time. That is why an axis selection code (Parameter 21) is required. Data sent back to the PC from the controllers is OR'ed together so that, if more than one box is transmitting, the data will be garbled. Because of this, the axis selection code must be unique for each controller.

The serial interface may be used in either a remote command mode or as just an Upload/Download path.



RS-232 Remote Command Mode

Parameter 21 must be non-zero for the remote command mode to operate as the controller looks for an axis select code defined by this parameter. The controller must also be in RUN mode to respond to the interface. Since the controller powers-on in RUN mode, remote unattended operation is thus possible.

Commands are sent to the controller in ASCII code and terminated with a carriage return (CR). A line feed (LF) is optional and is ignored. Responses that occur for some commands are also in ASCII and terminated by a CR and LF. All but one command must be preceded by the axis select code (U, V, W, X, Y, Z) and this is replaced by an x in the following list. Only the B command does not require the select code as it can be used to activate all axes simultaneously. The ASCII codes used to control via the RS-232 are:

RS-232 Commands

xSnn.nn	Specify step size or absolute position
xFnn.nn	Specify feed rate in units/second
xGnn	Specify G code
xLnnn	Specify loop count
xP	Interrogate servo status and position (This command causes the addressed controller to respond with the servo position if normal operation is possible or otherwise with the servo status.)
xB	Begin programmed step on X-axis
B	Begin programmed step on all axes at once
xH	Return to home position or use home offset
xC	Clear servo position to zero and establish zero
xO	Turn servo on
xE	Turn servo off where x is the selected axis.

RS-232 Responses

The xP command is presently the only command which responds with data. It will return a single line consisting of:

xnnn.nnn	(servo at standstill at position nnn.nnn) OR
xnnn.nnnR	(servo in motion past position nnn.nnn) OR
xOn	(servo is off with reason n) OR
xLn	(servo home position lost with reason n)

2.8 REMOTE OPERATION WITH A FANUC CNC CONTROL

FANUC control set-up requirements

There are several requirements that must be met before a Haas Servo Control can be interfaced with FANUC controlled mill. These are as follows:

1. FANUC control with custom macro enabled and parameter 6001, bits 1 and 4 set to "1".
2. A serial port on the FANUC control must be available for exclusive use by the Haas Servo Control while DPRNT program is running.
3. Single axis Servo Control and Indexer/Rotary Head. **NOTE:** A dual Axis Control will not work in this application as the RS-232 communication port is being used for internal communication.
4. RS-232 shielded cable 25' DB25M / DB25M (null modem not required) Radio Shack Catalogue no.RSU 10524 114 (see pinout below)
5. Shielded M-code relay cable Haas Automation Part Number : CNC

DB25 pinout:

1-1	2-2
3-3	4-4
5-5	6-6*
7-7	8-8*
20-20*	

*Not connected in the **brushless** control

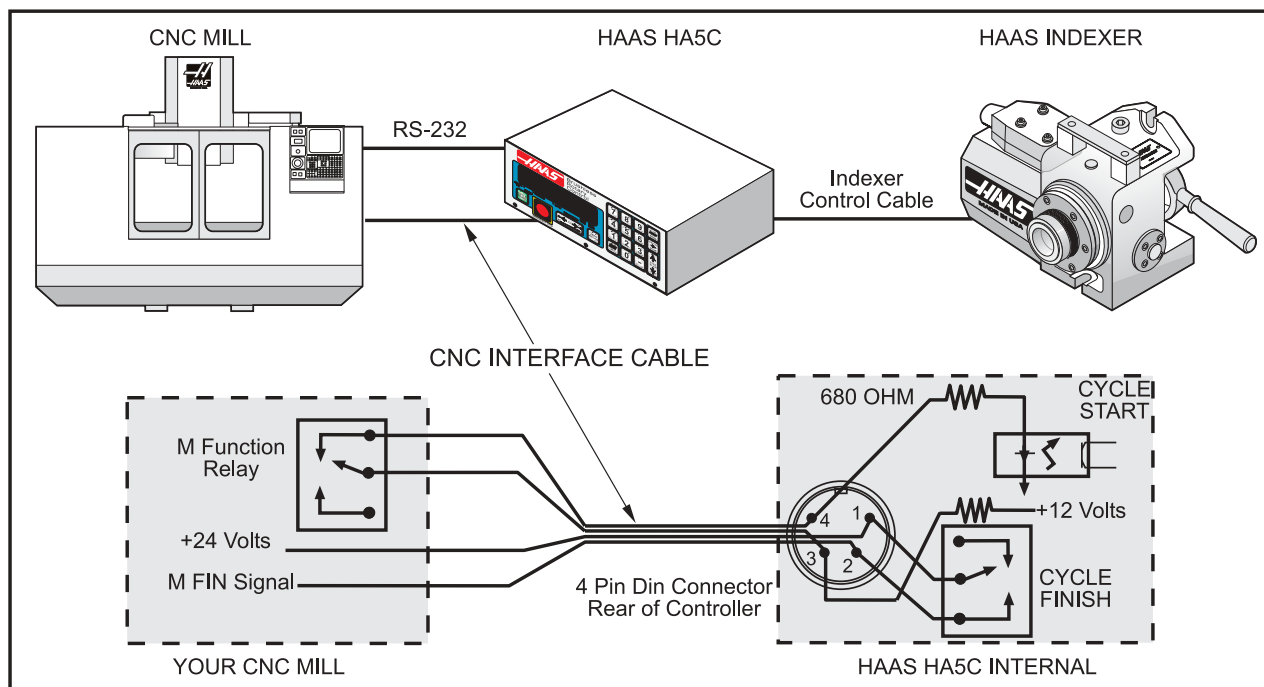

Figure 5. A Typical CNC Interface.



Haas Parameters

Once the above requirements have been met you can revise the parameters of the Haas control. Listed below are the parameters that will need to be changed.

- Parameter 1 = 1
- Parameter 5 = 0
- Parameter 10 = 0
- Parameter 13 = 65535
- Parameter 21 = 6* (see table 1)
- Parameter 31 = 0*
- Parameter 2 = 0
- Parameter 8 = 0
- Parameter 12 = 3*
- Parameter 14 = 65535
- Parameter 26 = 3* (see table 2)
- Parameter 33 = 1

Table 1

- 0= RS 232 upload / download programs
- 2= V
- 4= X
- 6=Z

- 1= U
- 3= W
- 5=Y
- 7,8 AND
- 9 RESERVED

Table 2

- 0 = 110
- 2 = 600
- 4 = 2400
- 6 = 7200
- 1 = 300
- 3 = 1200
- 5 = 4800
- 7 = 9600
- 8 = 19200

Fanuc Parameters

The Fanuc control parameters must be set as follows to successfully communicate with Haas Control.

- Baud Rate 1200*
- Parity Even (Required setting, do not experiment)
- Data Bits 7 or ISO (If CNC control defines Data bits as word length + parity bit then set to 8)
- Stop bits 2 (Required setting, do not experiment)
- Flow control XON / XOFF
- Character Coding (EIA/ISO) ISO (Required setting, EIA will not work)
- DPRNT EOB LF CR CR (CR is required, If is always ignored by Servo control)
- DPRNT leading zeroes as blanks off

*Initial settings. Experiment with these settings only AFTER interface is functional.

1. Be certain to set FANUC parameters related to actual serial port connected to Haas Servo Control. The parameters have been set for remote operation. You can now program, or run an existing program. There are several key items you need to consider to insure your program will run successfully. First and foremost DPRNT must proceed every command sent to the Haas Control. The commands are sent to the controller in ASCII code and terminated by a carriage return (cr.). All commands must be preceded by an axis select code (U, V, W, X, Y, Z), parameter 21 = 6. For this explanation Z will represent the axis code.

RS 232 Command Blocks

- DPRNT[] Clear / Reset receive buffer
- DPRNT [ZGnn] Loads G-code nn into step no. 00, □□ is a place holder
- DPRNT[ZSnn.nnn] Loads Step Size nnn.nnn into Step no. 00
- DPRNT[ZFnn.nnn] Loads Feed Rate nnn.nnn into Step no. 00
- DPRNT[ZLnnn] *Loads Loop Count into Step no. 00
- DPRNT[ZH] Return home immediately without M-FIN
- DPRNT [ZB] *Activates Remote Cycle Start without M-FIN
- DPRNT [B] *Activates Remote Cycle Start without M-FIN regardless of Haas Servo Control Parameter 21 setting

*Not for general use in this application.



NOTES:

1. Use of "Z" above assumes Haas Servo Control Parameter 21 = 6
2. Leading and trailing "0" must be included (Correct: S045.000, Wrong: S45.)
3. When writing your program in the FANUC format it is important **not** to have blank spaces or carriage returns (CR) in your DPRNT statement.

The following is an Example of one way to program the FANUC.

```
O0001
G00 G17 G40 G49 G80 G90 G98
T101 M06
G54 X0 Y0 S1000 M03
POPEN                ( OPEN FANUC SERIAL PORT)
DPRNT [ ]            ( CLEAR /RESET HAAS)
G04 P64
DPRNT [ZG090]        ( SERVO CONTROL STEP SHOULD NOW READ [00] )
G04 P64
DPRNT [ZS000.000]    ( LOADS STEP SIZE 000.000 INTO STEP 00)
G04 P64
DPRNT [ZF050.000]    ( LOADS FEED RATE 50 UNITS / SEC INTO STEP 00)
G04 P64
Mnn                  (REMOTE CYCLE START, MOVES TO P000.0000, SENDS M-FIN)
G04 P250              (DWELLS TO AVOID DPRNT WHILE M-FIN IS STILL HIGH)
G43 Z1. H01 M08
G81 Z-.5 F3. R.1      (DRILLS AT: X0 Y0 P000.000)
DPRNT [ ]            (MAKE CERTAIN HAAS INPUT BUFFER IS CLEAR )
G04 P64
#100 = 90.            (EXAMPLE OF CORRECT MACRO SUBSTITUTION)
DPRNT [ZS#100[33] ]  ( LOADS STEP SIZE 090.000 INTO STEP 00)
                      (LEADING ZERO CONVERTED TO SPACE PARAM. MUST BE OFF)

G04 P64
Mnn                  (REMOTE CYCLE START MOVES TO P090.000, SENDS M-FIN)
G04 P250
X0                   (DRILLS AT: X0 Y0 P090.000)
G80                  (CANCELS DRILL CYCLE)
PCLOS                (CLOSE FANUC SERIAL PORT)
G00 Z0 H0
M05
M30
```



2.9 UPLOAD / DOWNLOAD

The serial interface may be used to upload or download a program the same as with almost any other CNC in use today. All data is sent and received in ASCII code. Lines sent by the controller are terminated by a carriage return (CR) and line feed (LF). Lines sent to the controller may contain a LF but it is ignored and the lines are terminated by a CR. It is important that parameter 21 be set to "1" in the Servo Control prior to attempting Uploading or Downloading programs.

An upload or download is started from the PROGRAM mode with the G code displayed. To start an upload or download, press the minus (-) key while the G code is displayed and blinking. The display will then show:

Prog n

where **n** is the currently selected program number. You can select a different program by pressing a number key and then START to return to PROGRAM mode or MODE to return to RUN mode. Or you can press the minus (-) key again and the display will show:

SEnd n

where **n** is the currently selected program number. You can select a different program by pressing a number key and then START to begin sending that selected program. Or you can press the minus (-) key again and the display will show:

rEcE n

where **n** is the currently selected program number. You can select a different program by pressing a number key and then START to begin receiving that selected program. Or you can press the minus (-) key again and the display will return to PROGRAM mode. Both uploading and downloading can be terminated by pressing the CLR button.

Programs sent or received by the controller have the following format:

```
(Sample Only)
%
N01 G91 S045.000 F080.000 L002
N02 G90 S000.000 F100.000
N03 G98 F050.000 L013
N04 G96 P02
N05 G99
%
```

The % must be found before the controller will process any input and it will always begin output with a %. The N code and G code all found on all lines and the remaining codes are present as required by the G code. The N code is the same as the step number display in the controller. All N codes must be continuous starting from 1. The controller will always end output with a % and input to it is terminated by a %, N99 or G99. Spaces are only allowed where shown.

Upload/Download functions do not need an axis select code as they are manually initiated by an operator at the front panel. However, if the select code (Parameter 21) is not zero, an attempt to send a program to the control will fail as the lines do not begin with the correct axis select code.



2.10 HA2TS SETUP AND OPERATION

1. Position Tailstock relative to work piece within the first 3/4" to 1-1/4" of spindle travel. This will optimize spindle rigidity. (Fig. 1 Item A)
2. Tailstock to HA5C head alignment can be accomplished by simply pushing the tailstock (Fig. 1 Item B) to one side of the T-slots prior to tightening the flange nuts to 50 ft-lbs. Precision locating pins mounted on the bottom of the tailstock allow for quick alignment as the pins are parallel within 0.001 of the spindle bore. However, make sure both tailstock units are positioned to the same side T-slot. This general alignment is all that is needed for the recommended use of live centers.
3. Tailstock Pressure settings: Set the air regulator (Fig. 1 Item C) to the normal operating range for HA5C indexers, 5-40 psi. with a maximum 60 psi. Haas recommend using the lowest air pressure setting that provides the required rigidity for the part be machined. Note: When using HA5C indexers, Haas Automation recommends using LIVE CENTERS ONLY! Refer to the Tailstock section of the manual for more information.

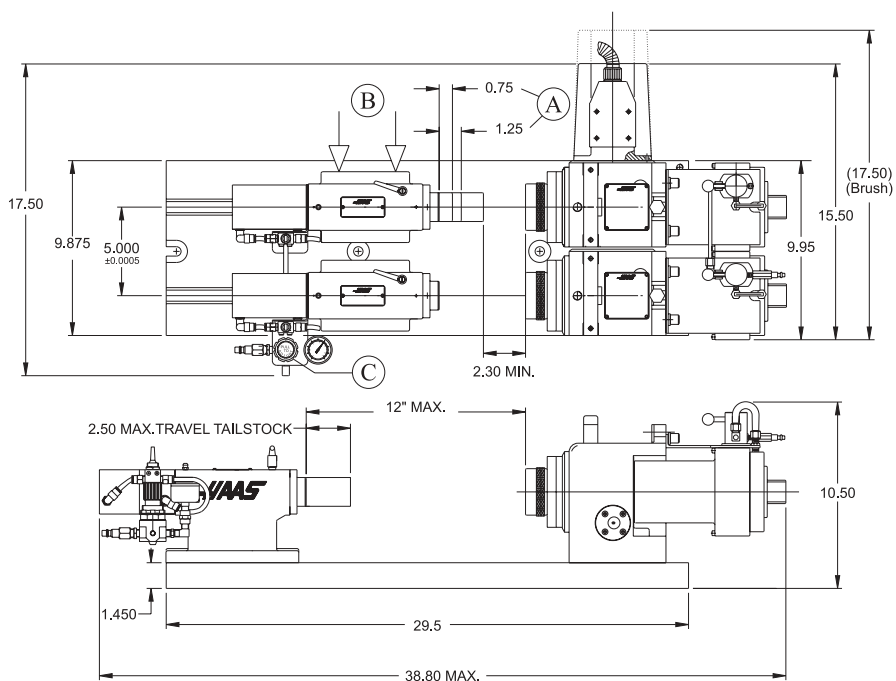



2.11 USE OF COLLETS, CHUCKS, AND FACE PLATES

The unit accepts standard 5C collets and step collets. When inserting the collets, align the keyway on the collet with the pin inside the spindle. Push the collet in and turn the collet drawbar clockwise until proper collet tightness is obtained. Detailed collet installation instructions for model **AC 25/100/125** collet closers are provided later in this section.

Chucks and face plates utilize the 2 3/16-10 threaded nose on the spindle. We recommend using chucks that are 5" diameter or smaller and weigh less than 20 pounds. Pay special attention when installing chucks. Always make sure that the thread and the outside diameter of the spindle are free of dirt and chips. Apply a thin coating of oil to the spindle. Screw the chuck on gently until it seats against the rear of the spindle. Tighten the chuck to approximately 70 ft.-lb with a strap wrench. Always use a firm, steady pressure to remove or install chucks or face plates. This is very important to prevent damage to the indexing head.

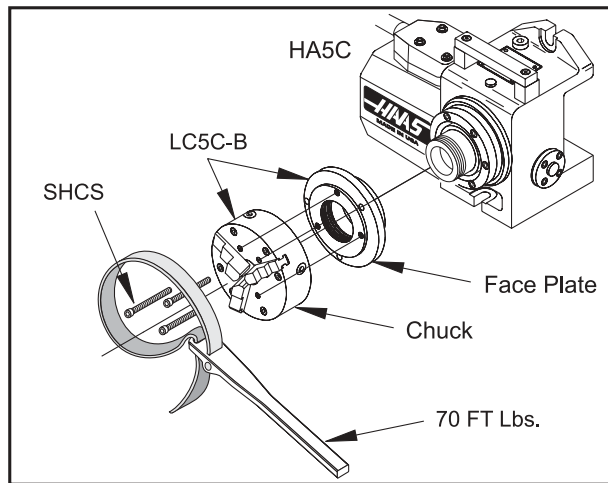

WARNING!

Never use a hammer or pry bar to tighten the chuck, as this will damage the precision bearings inside your unit.



2.12 HAAS 5C AIR COLLET CLOSERS (MODEL AC25 / AC100 / AC125)

There are three types of Air Collet Closers available: Model **AC25** (Item G) may be used on the old-style indexer (S5C) or the newer model HA5C, and Models **AC100/125** are for the newer indexer only (HA5C). Model **AC25** is a non thru-hole type closer and holds parts by utilizing shop air pressure through a mechanical multiplier to provide between 0 and 3000 pounds of draw force, depending on air pressure supplied. The mechanical portion provides .03" of longitudinal movement so diameter variations of up to .007" can be clamped securely without readjustment.

The **AC100** (Item H) is a thru-hole type closer and holds parts by utilizing spring force coupled through a mechanical multiplier to provide up to 10,000 pounds of draw force. The mechanical portion provides .025" of longitudinal movement so diameter variations of up to .006" can be clamped securely without readjustment. Recommended air pressure is 120 psi.; it is required to be no less than 85 psi.

The **AC125** (Item F) air collet closer has a 5/16" thru-hole that will allow small diameter stock to extend out the back of the unit. The **AC125** also has a large diameter counterbore in the drawtube that will allow any size stock that will pass through a standard 5C collet to protrude approximately 1.6" out the back of the collet. This also allows the use of most standard collet stops. The **AC125** uses 80-120 psi of air pressure through a mechanical multiplier to provide up to 12,000 lb. of draw force (adjustable through the use of an air pressure regulator supplied by the customer.) The drawtube travel of 0.060" allows the unit to accommodate part diametrical variations of up to 0.015" without readjustment. An air regulator is recommended.

2.13 REPLACING MANUAL COLLET CLOSER WITH AIR ACTUATED COLLET CLOSER

Collet Closer Installation (Model AC25 / AC100 / AC125)

Before installing the **AC25/100/125** on the HA5C, you must first remove the manual collet closer assembly (Item B). Remove the top and bottom mounting bolts for the handle (Item A) and slide the handle off the collet closer assembly. With the collet removed, slide the collet closer assembly out the back of the spindle. Remove the flathead screw (Item C) and locking pawl (Item D) and unscrew the spindle nut (Item E). (It may be necessary to use two 1/8" pins and a screwdriver to break the spindle nut loose.)

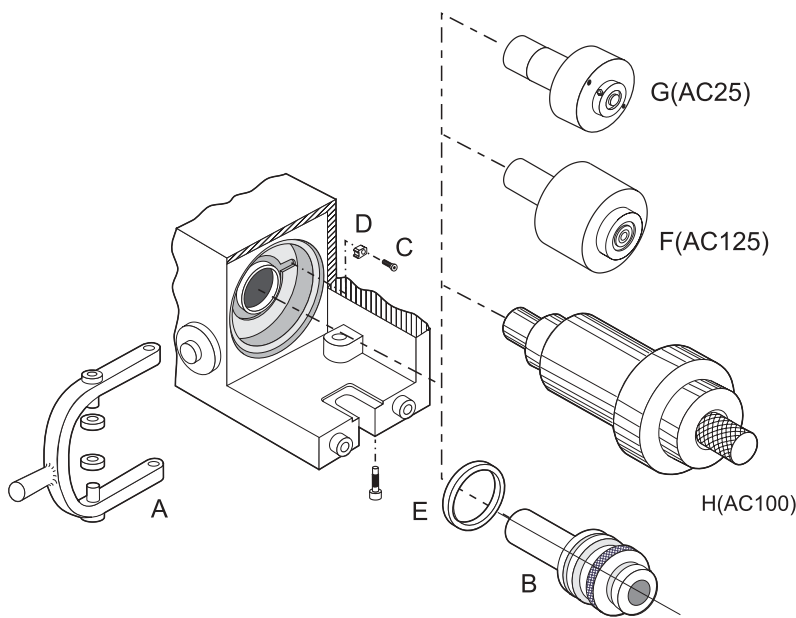

Replacing the manual collet closer with a model AC25, AC100, or AC125 Air Collet Closer.



AC25 Collet Closer

To install the AC25, install new spindle nut (Item F), locking pawl (Item G) and FHCS (Item H) Insert drawtube of assembled AC25 (Item I) into back of HA5C spindle and screw the main body onto the back of the spindle. Tighten with strap wrench to approximately 30 ft-lb. Mount valve assembly (Item J) to top of HA5C as shown using 1/2-13 SHCS (Item K). Assemble fittings of copper tube (Item L) between valve and fitting on back of collet closure and tighten.

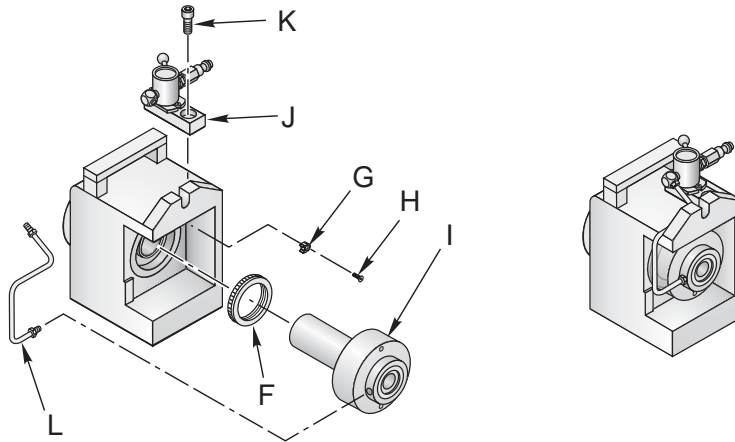

CAUTION! The Model **AC25** Collet Closer relies on your air pressure to maintain clamping force and will release if the air supply is accidentally removed. If this presents a fail-safe problem, then an air switch should be installed in-line to stop machining operations if the air supply should fail.

AC100 Collet Closer

To install the **AC100**, assemble the brass air fittings with the valve and slip ring as shown in the figure. When assembling the fittings, ensure the fittings are all tight and square with the valve. Mount the valve to the bracket with the 10-32 x 3/8 BHCS. Bolt the bracket to the back of the indexing head with the 1/4-20 x 1/2 SHCS and 1/4 split lock washers. Ensure the slip ring and bracket are square so that the unit can rotate freely before tightening down the bracket. Connect the valve and slip ring with the copper tubing and tighten down these fittings.

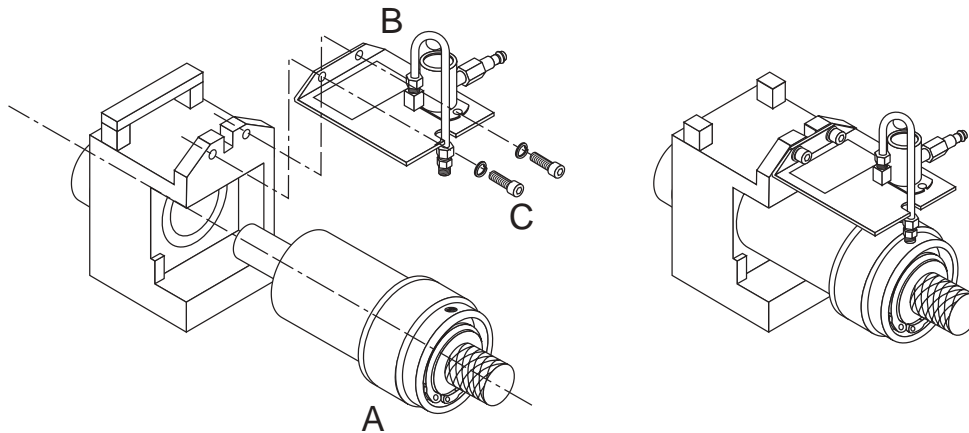

Replacing the manual collet closer with a model AC100 Air Collet Closer.

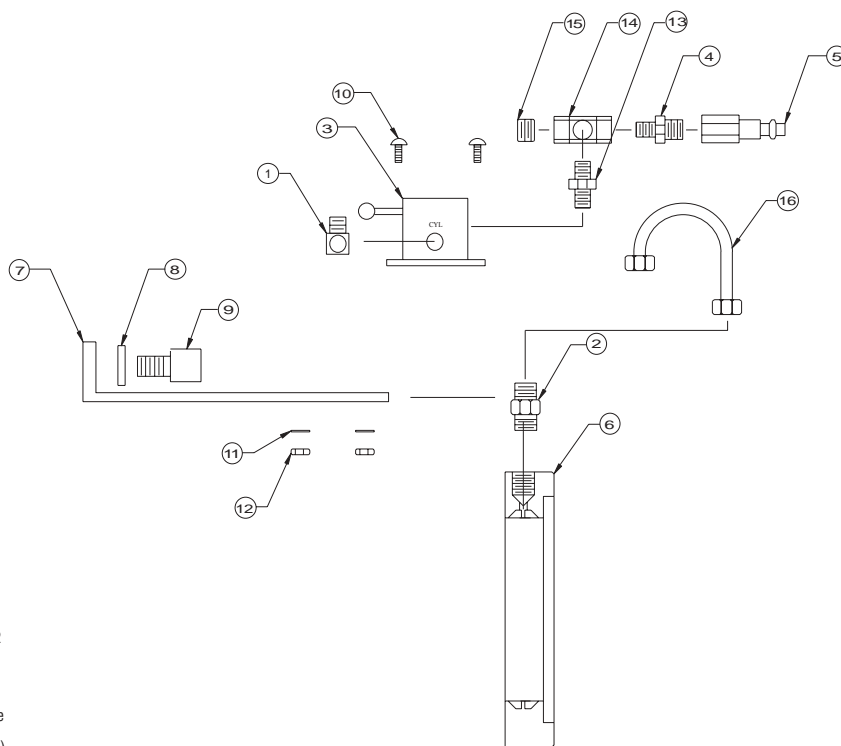

MATERIALS

- 1. 90 Comp. Fitting
- 2. Male Comp. Fitting
- 3. Valve
- 4. 1/4 Male Adaptor
- 5. Quick Release
- 6. Slip Ring
- 7. Bracket
- 8. Washer 1/4 Split
- 9. SHCS, 1/4-20 x 1/2
- 10. BHCS, 10-32 x 3/8
- 11. Washer, #10 Star
- 12. Hex Nut, 10-32
- 13. Male Hex JCT.
- 14. 1/8 NPT Female Tee
- 15. 1/8-27 Pipe Plug
- 16. Copper Tube (4026)

AC100 Valve Assembly and slip ring (AC100).

CAUTION! The Model **AC100** Collet Closer is designed to clamp parts when the air pressure is OFF. Do not index while air pressure is being supplied to the unit, as this will cause excessive loading on the slip ring and will damage the motor.



AC125 Collet Closer

Insert the drawtube of the assembled AC125 (Item A) into the back of the HA5C spindle and screw the main body onto the back of the spindle. Tighten with a strap wrench to approximately 30 ft./lbs. Mount the valve assembly (Item B) to the top of the HA5C as shown using 1/2-13 SHCS (Item C). Assemble the fitting (Item D) and copper tube (Item E) between the valve and fitting on the back of the collet closure and tighten.

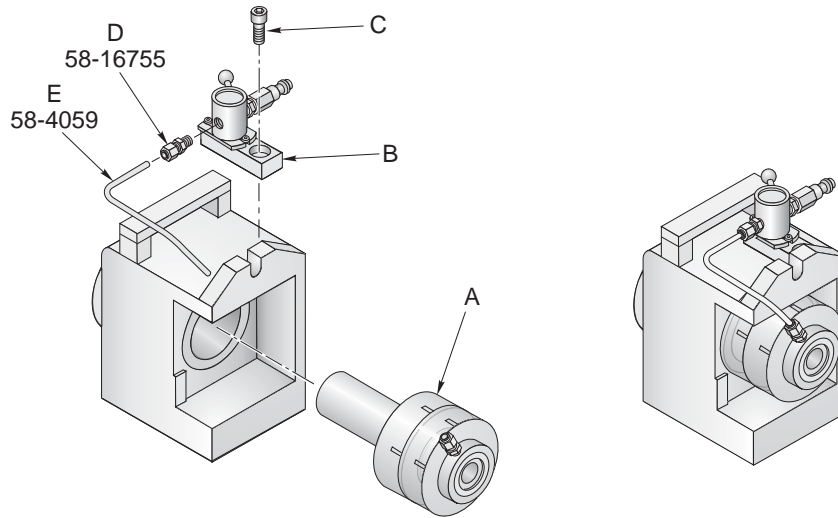

Replacing the manual collet closer with a model AC125 Air Collet Closer.

Never use hammer blows to remove or install these items. The shock will damage the precision bearings and gears inside your HA5C.

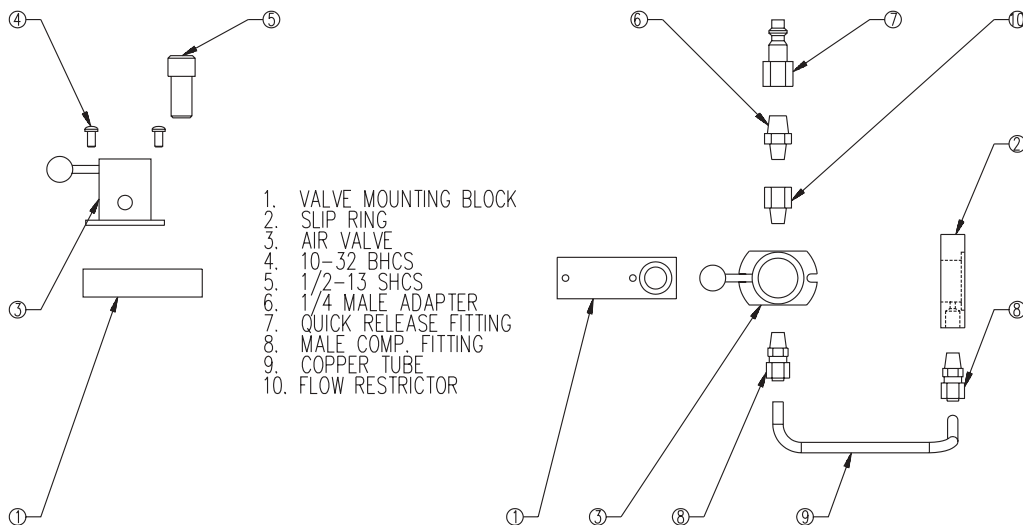

* The flow restrictor does not exist on the AC25.

Assembly of valve and slip ring (AC 25/ 125).

Collet Closer Removal (Model AC25 / AC100 / AC125)

Air collet closers fitted at the factory are not intended to be removed. However if servicing is required use a woven strap wrench to remove the collet assembly. Do not use a hammer or impact wrench to remove the closer bodies as damage may occur to the gear and bearing sets. When re-installing the collet closer use a strap wrench and tighten to approximately 30 ft.-lbs.



2.14 USE OF COLLETS WITH HAAS COLLET CLOSERS

NOTE: All collets must be free from burrs and in good condition.

Collet Installation (AC25)

To install a collet, line the collet keyway up with the spindle key and insert the collet. There are two ways to turn the draw tube to adjust the collet:

1. If you are using a collet with an 11/64" or larger opening, you can insert a 9/64" hex wrench through the collet to turn the draw tube.
2. If you are using a collet with an opening smaller than 11/64", you can adjust the collet by turning the draw tube with a pin through a slot. Look between the back face of the worm gear and collet closer and you will see some holes in the draw tube. If they are not visible, jog the spindle until they come into position. Use a 9/64 diameter pin to rotate the draw tube and tighten the collet in position. There are 15 adjustment holes, so it will take 15 steps to turn the draw tube one full revolution. Put a part in the collet and tighten until it grips the part then back the draw tube off ¼ to ½ turn.

NOTE: Multi-spindle and HA5C units require a minimum collet of 11/64" (Option #2 not possible due to lack of clearance.)

Collet Installation (AC100)

NOTE: For best performance, the **AC100** should operate at 120 psi, and no less than 85 psi.

Align the collet keyway with the spindle key and insert the collet. Hold the collet in place and tighten down the drawbar by hand. With the air pressure valve **on**, place your part in the collet and tighten the drawbar until it stops. Back off ¼-½ turn then turn the air **off**. The collet will clamp your part with maximum holding power.

For thin-walled or fragile parts, turn the air pressure off, place your part in the collet, and tighten the drawbar until it stops. This is your starting point for adjustment at the loose end. Turn the air pressure valve on and tighten the drawbar ¼-½ turn. Turn the air off and the collet will begin to clamp your part. Repeat until you achieve the desired amount of clamping force.

Collet Installation (Model AC125)

To install a collet in the **AC125**, align the collet keyway with the spindle key and insert the collet. Insert a 5/16" hex wrench into the hex in the back of the drawtube, and turn the drawtube to engage the collet. Turn the drawtube until it grips the part, and then back off approximately 1/4 turn. This will be a good starting point for fine-tuning the grip range.

Collet Sticking

NOTE: To prevent excessive wear and collet sticking, make sure collets are in good condition and free from burrs. A light coat of Molybdenum grease on the collet wear surfaces will extend the life of the spindle/collet and help prevent sticking.

When using the **AC25**, releasing a collet is accomplished by removing the air supply. It is then pushed out by a heavy spring inside the air collet.



The **AC100** uses shop air to move the drawbar forward and release the collet. Increasing the air pressure can help free the collet when it sticks; however, do not exceed 150 psi.

The **AC125** uses shop air to pull the drawtube in, and a heavy internal spring to push the drawtube out and release the collet. If, after repeated use, the spring will not push the collet out, use one of the following methods to remove the collet and lubricate the outside of the collet with a light grease before re-inserting:

1. If the three-way air valve provided with the unit becomes clogged with contaminants, the exhaust airflow may be restricted, which may cause the collet to stick in the taper. If this situation arises, leave the valve in the clamped position, and connect and disconnect the air supply several times in rapid succession.
2. If the above procedure does not free the collet, switch the valve to the unclamped position, then gently tap the back end of the drawtube with a plastic faced mallet.

2.15 TOOLING LOCATIONS

The HA5C is equipped with tooling points in order to speed setups. One of the most time-consuming procedures in setup is aligning the head with the table. On the mounting surfaces there are two 0.500 bored holes on 3.000 centers. The holes on the bottom surface are parallel to the spindle within 0.0005 per 6 inches and on center within ± 0.001 . By boring matching holes in your tooling plate, setups become routine. Using the tooling holes will also prevent the head from shifting on the mill table when the part is subjected to heavy cutting forces.

On CNC mills, a machined stepped plug of 0.500 diameter one side and 0.625 on the other comes with the HAAS head. The 0.625 diameter fits into the T-slot of the mill table. This will give quick parallel alignment that will be close enough for most jobs.



3. OPERATION

3.1 FRONT PANEL DISPLAY

The Light Emitting Diode (LED) front panel display tells you what is going on inside the controller. There are nine characters that are displayed. The left two characters are the step number and go from 1 to 99. They cannot be changed with the numeric keys and are selected by using the STEP SCAN button arrows. The remaining seven characters display data that is stored in memory. Every step (or block) contains several pieces of information that are necessary for your program, but they cannot be displayed simultaneously. In order to overcome this, use the DISPLAY SCAN button to view the pieces of data for each step. The data is preceded by a letter to indicate which piece of information is being displayed. For example, if an **F** precedes the number, the displayed data is for feed rates. There are five such registers. They are:

1. Current spindle position (indicated by a letter **P**)
2. Step size and direction (indicated by no letters),
3. Feed rate (indicated by a letter **F**),
4. Loop count (indicated by a letter **L**)
5. G code (indicated by a letter **G**)

Successive pushes of the **right** arrow button will cause the display to cycle to the next register, that is, POSITION - STEP SIZE - FEED RATE - LOOP COUNT - G CODE - POSITION - etc. In RUN mode, the **right** arrow button can select among any of these five displays. In PROGRAM mode, all of these but the position may be displayed.

Refer to the diagram on the following page. When you are in the PROGRAM mode, you are editing the numbers (or registers) inside the dotted lines. Think of the LED displays as a window that allows you to see only one number of the program at a time. The DISPLAY SCAN button allows you to scan sideways and see all the information for a single step. Pushing the DISPLAY SCAN button shifts the window one place to the right, looping from left to right at the end of the row. Pushing the **up** arrow allows you to view the previous step, while pushing the **down** arrow allows you to view the next step. Using these three keys, you can scan to anywhere in the program. If you enter a new number in that position, the number will be stored when you scan to another position or return to RUN mode.

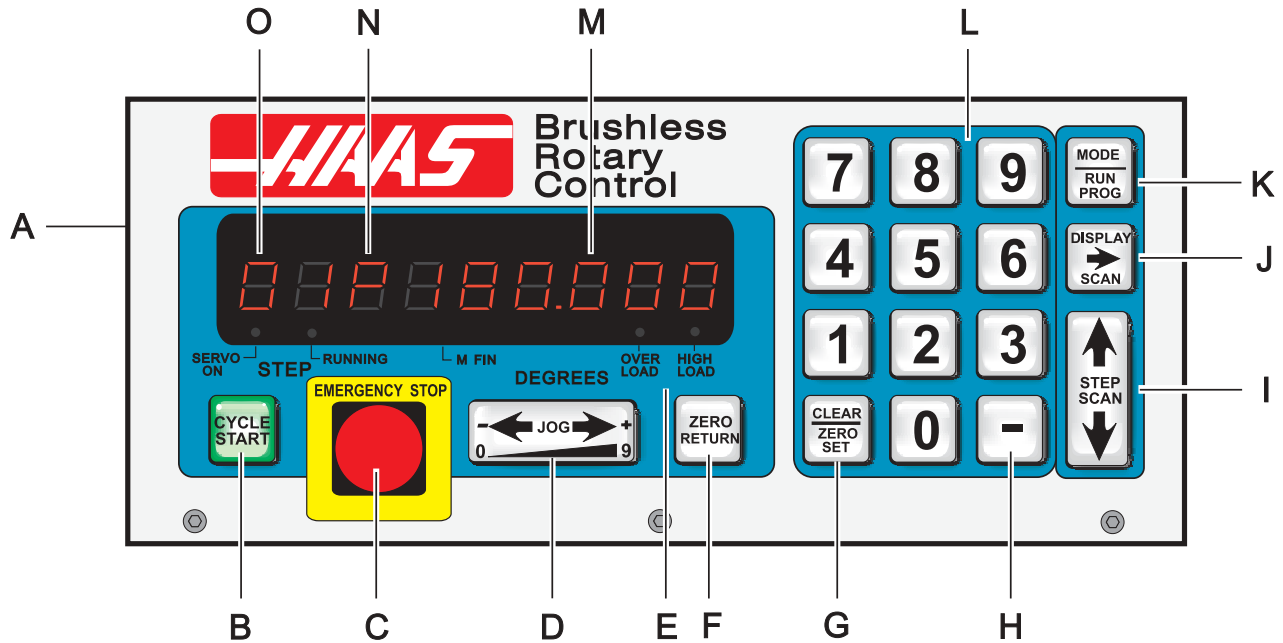

- A) Main power switch to turn the unit on, located on the rear (Main POWER switch for the brush control is located on the front panel).
- B) CYCLE START begins a step, stops a continued operation, inserts a step, or turns the servo on.
- C) EMERGENCY STOP turns off the servo when on and aborts a step in progress.
- D) JOG causes the servo to move in either the forward or backward direction at a rate defined by the last numeric key pressed.
- E) Load meter LED. If LEDs are illuminated continuously during a low feed rate or when stationary, the following conditions apply:

HIGH LOAD: Indicates overload level, excessive load or workpiece support misalignment. Hi-LoAd or Hi Curr alarms may occur if not corrected. (See "Troubleshooting" section)

OVERLOAD: Indicates 2x overload level, excessive load or workpiece misalignment. Hi LoAd or Hi Curr alarms will occur if not corrected. Damage to motor or table may result. (See "Troubleshooting" section)

NOTE: It is normal for the LEDs to be illuminated during a rapid movement or high duty cycle.

- F) ZERO RETURN causes the servo to return to HOME position, search for mechanical HOME, delete a step, or move forward to the mechanical offset.
- G) ZERO SET clears the entered data, resets program to 0, or defines the present servo position as HOME.
- H) MINUS KEY selects negative step values or Prog/Upload/Download functions.
- I) STEP SCAN scans step numbers from 1 through 99.
- J) DISPLAY SCAN scans the display to show either Position, Step Angle, Feed Rate, Loop Counts, or G Code.
- K) MODE / RUN PROG switches from RUN mode to PROGRAM mode (blinking display).
- L) Data entry keys and jog speed selection.
- M) Displays show current data, i.e., a current spindle position of 180.
- N) Indicates what data is being displayed. Either **P**, **F**, **L**, blank, or **G** for Position, Feed Rates, Loop Count, Step Angle, or G Code.
- O) Present step number. Step numbers 1 to 99 are available. Also displays errors at turn on.



3.2 TURNING THE SERVO ON

There is a single 115V AC @ 15 amps supply required by the controller. Ensure that the front panel power switch is turned off (brushless units have the power switch on the rear) and connect the motor cable from the indexer and the power cord.

Turn the controller on. The display will show:

HAAS nn

where **nn** is the software revision number. That number should be used when describing problems to Haas. If any other message is displayed, refer to the "**Error Codes**" section of this manual. The number only remains in the display for about one second. After one second, the front panel displays should indicate:

Por On

This indicates that the servo is turned off (no power is applied to the closed-loop motor).

In addition, the internal battery is checked at power-on and if the battery is low the following message is displayed:

Lo bAt

Pressing any key will allow you to continue operation but the low battery may have caused loss of your program parameters.

Press the front panel START switch once. The panel should now indicate:

01 no Ho

This indicates that the motor is now powered but the zero position is not yet defined (there is no home).

3.3 FINDING THE ZERO POSITION

Press the ZERO RETURN button to start the automatic homing operation. When the indexer stops, the display will indicate:

01 Pnnn.nnn

If the display shows a non-zero number, press the clear key for three seconds.

3.4 OFFSETTING THE ZERO POSITION

Use the left/right JOG switch to position the indexer to the position that you want to use as zero and then press and hold the CLR key for three seconds. The display should now indicate:

01 P 000.000

This indicates that the zero position is established and the controller is ready to begin normal operations. If a different position is to be used as zero, jog the indexer to the new position and press the CLR key for three seconds. The display will again indicate:

01 P 000.000

If you had previously cleared a new home position for the indexer, the display will show a non-zero position. In this case, press the ZERO RETURN button once more and the indexer will move forward to the pre-defined zero position.



3.5 JOGGING

Jogging of the motor can be done with the front panel JOG switch. The jog speed is selected with the front panel number keys and is a fraction of the maximum feed rate set by the parameters. The jog speeds are:

Number pressed	Speed (% of maximum)	Speed (for 270 deg/sec max.)
0	0.008	0.021
1	0.015	0.040
2	0.031	0.084
3	0.062	0.167
4	0.125	0.338
5	0.25 (default)	0.675
6	0.5	1.350
7	1.0	2.700
8	4.0	10.800
9	16.0	43.200

If the control is set up for linear motion, there are both positive and negative travel limits possible. If a step is started which would have caused the control to exceed the travel limits, the following message is shown:

2 FAr

and the control will not execute the step. (See parameter 13 and 14, travel range)

3.6 ERROR CODES

When the controller is first turned on, a set of self tests is run and the results may indicate a controller fault. Any of these could result in an **En** display of one of the following codes:

Blank front panel	Program CRC failure (bad RAM, or cycle power if bad ROM to RAM program transfer).
E0 EProm	EPROM CRC error
FP Short	Front panel switch closed (or PIO fault)
rE Short	Remote START switch closed and enabled
E3 rAm	RAM cannot store data
E4 bAtt	Saved program is in error (low battery)
E5 Pio2	PIO2 is bad
E6 Pio3	PIO3 is bad
Lo Volt	Power-fail interrupt (low line voltage)
E8 Encod	Encoder chip bad
E9 intEr	Interrupt problem
EA no go	Keep alive circuit failure
Eb nmi	NMI sense bad
Ec Pwm	PWM generation bad
Ed cloc	1 kHz signal missing
EE Au in	Auxiliary input 2 shorted
Lo bAt	Low battery (Get serviced)

Intermittent low voltage errors or power failures may be the result of inadequate power to the controller. Use heavy duty extension cords only and keep them as short as possible. Make sure power service is a minimum of 15 amps at the plug and that the voltage is a minimum of 115V AC.

0 too SL (Zero margin too small) Zero margin too small is the distance between the home switch and the final stopped motor position, after seeking home, is either less than 1/8 or greater than 7/8 of a motor revolution.



This alarm may occur while homing the rotary table. The distance between the home switch and the final motor position at zero is less than 1/8 of a motor revolution. To prevent this alarm, parameter 45 must be set properly. Start with the default value for parameter 45 (0) and add 1/2 of a motor revolution (1/2 motor revolution is equal to the value in parameter 28 divided by 2). Home the rotary table after the new value for parameter 45 has been entered.

There are no user-serviceable parts inside, so refer all problems to HAAS Automation for repair.

3.7 SERVO OFF CODES

At any time the servo is turned off, a reason code is displayed along with the following codes. The codes are:

Por On	Power was just turned on (or failed prev.)
Ser Err	Servo following error too large
E-StoP	Emergency stop
Hi LoAd	Software fuse
rS-232	Remote RS-232 commanded off
Air-Hot	Motor overheat sensor
EncodEr	Z channel fault (bad encoder or cable)
Hi Curr	Over current limit (stalled or PCB fault)
EncodES	Z channel missing (bad encoder or cable)
Hi VoLt	Regen overheat (high line voltage)
CAbLE	Broken cable has been detected from encoder
PHAS Er	Power up phase error. (brushless only)
dr FLt	An overcurrent or drive fault. (brushless only)
trAnS	Encoder transition fault had been detected by the brushless circuitry.
Indr dn	Platter not fully up (HRT320FB only). Can be caused by low air pressure.

3.8 EMERGENCY STOP

Pushing the EMERGENCY STOP button will turn the servo off and cause the spindle to decelerate and stop. Position will not be lost. If the step was not completed you will still be on that step. Push CYCLE START to turn the servo on. The remote cycle start and cycle finish will not function until the EMERGENCY STOP is removed by pushing the START button. If an EMERGENCY STOP is performed, the display will indicate an:

E-StoP

CE machines have an Emergency-stop switch on the top of the control. Pressing the E-stop switch will turn off the servo and aborts the step in progress.



4. PROGRAMMING THE CONTROLLER

4.1 INTRODUCTION

Programming is done through the square 15-key keypad on the right side of the front panel. The three buttons on the right column of the keypad are used for program control. They are the:

- MODE / RUN PROG** button,
- DISPLAY SCAN (RIGHT ARROW)** button
- STEP SCAN (UP/DOWN ARROWS)** button

The MODE button is the most important. It selects between the RUN mode and PROGRAM mode. You can tell which mode you are in by looking at the display.

- IF THE DISPLAY IS STEADY, YOU ARE IN THE RUN MODE.**
- IF IT IS FLASHING ON AND OFF, YOU ARE IN THE PROGRAM MODE.**

The RUN mode is where pre-programmed commands may be executed and the PROGRAM mode where commands are entered into memory. The servo loop can be turned on in either mode and will hold the motor to a commanded position when at standstill.

When the controller is first turned on, it is in RUN mode but the servo is turned off. This is indicated by:

Por On

Pressing any key will allow you to continue operation.

Always push and immediately release a button. Pushing and holding a button down will cause the button to repeat, which is useful when scanning a long program. Some buttons have more than one function depending upon which mode you are in.

4.2 HOW DATA IS STORED IN THE CONTROLLER'S MEMORY

Step Number	Step Size	Feed Rate	Loop Count	G code
1	90.00	270	01	91
2	-30.00	05	01	91
3	0	270	01	99
through 99	0	270	01	99

-Your program data-

window Pushing the **right** arrow key moves the window to the right.

Pushing the **up** arrow or **down** arrow keys moves the window up or down.



4.3 ENTERING A STEP

To enter a step into the controller's memory, press the MODE button. This will put the controller into the PROGRAM mode. The display will begin blinking and show a step size. Clear the last program by pressing and holding the CLR key for three seconds. To enter a **45 degree** (45°) step, press the following keys:

4 5 0 0 0

The display should now indicate:

01 45.000

Press the **right** arrow button. This will cause the **45 degree** (45°) step to be stored and the feed rate to be displayed. To enter a feed rate of **250 degrees** (250°) per second, press the following keys:

2 5 0 0 0 0

The display should now indicate:

01 F 250.000

To return the controller to the RUN mode, press the MODE button. The display should now indicate:

01 P 000.000

Start the **45 degree** (45°) step by pressing the START button. The indexer should move to the new position and, at the end of the step, the display should indicate:

01 P045.000

For more details on operating and programming the controller, see the following section.

4.4 PUTTING A PROGRAM INTO MEMORY

Programming begins with ensuring that the controller is in PROGRAM mode and at step number 01. To do this, press the MODE button while the servo is NOT in motion. **The displays must be blinking.** Next, push and HOLD the CLR key for five seconds. You have now cleared the memory and are at step one and ready to begin programming. "01 000.000" should be displayed. Please note that you do not have to clear the memory each time you wish to enter or change data. Data in the program can be changed simply by writing the new data over the old.

Up to 7 programs can be stored, number 0-6. To access a different program, press the minus key while showing a G code. The display will change to:

Prog n

Press a number key to select a new program and then press the MODE key to return to RUN mode or the START key to continue with the PROGRAM mode

Every one of the possible 99 steps in a program may contain the following:

1. a step size or position command shown as a number with possible minus sign,
2. a feed rate shown with a preceding **F**,
3. a loop count shown with a preceding **L**,
4. a G code shown with a preceding **g**, and
5. a jump destination with a preceding **Loc**.



Every step contains at least one G code. The following section describes the possible G codes.

To display the additional codes associated with a step, press the **right** arrow key. Possible data entry includes:

- Step size (no code letter but possible minus sign),
- Feed rate (**F**),
- Loop count (**L**),
- G code (**g**), and
- Subroutine jump destination step number (**Loc**)

Some of these entries are not allowed for particular G codes and either cannot be entered or are ignored. Most steps are incremental position commands and this is the default G code (91). The G codes 86, 87, 89, 92, and 93 should be used with the CNC relay function disabled (Parameter 1 = 2).

Enter your step size in degrees to three decimal places. The decimal places must always be entered, even if they are zero. Enter a minus sign (-) for opposite rotation. If you need to edit a feed rate or loop count, push the **right** arrow key to view that register and input the data.

If you are programming for a part that does not utilize feed rates or loop counts, simply push the **down** arrow to go to the next step. Insert the G code and step size and move on to the next step. The step will automatically be set to the fastest feed rate and a loop count of one.

**THE DATA YOU INPUT IS AUTOMATICALLY STORED IN MEMORY
WHENEVER YOU PUSH ONE OF THE CONTROL BUTTONS.**

If you enter a wrong number, or one that is out of limits, the control will display an error message:

Error

To correct this, push the CLR button and re-enter the correct number. If you are entering the correct number and **Error** still appears, check Parameter 7 for memory protect.

When the last step has been entered, an end code must be present at the following step. Steps 2 through 99 are set to the end code when a clear memory is performed. This means that you usually do not need to set the last step to 99. If you are removing steps from an existing program, make sure that you have entered a (99) after the last step.



4.5 G CODES

The following G codes are possible:

G28	return to home position (same as G90 with step 0)
G73	peck cycle (linear operation only)
G85	fractional circle division
G86	turn CNC relay on
G87	turn CNC relay off
G88	return to HOME position (same as G90 with step 0)
G89	wait for remote input
G90	absolute position command
G91	incremental command
G92	pulse CNC relay and wait for remote input
G93	pulse CNC relay
G94	pulse CNC relay and run next L steps automatically
G95	end of program/return but more steps follow
G96	subroutine call/jump (destination is a step number)
G97	delay by L count/10 seconds (down to 0.1 second)
G98	circle division (circular operation only)
G99	end of program/return and end of steps

4.6 ABSOLUTE / INCREMENTAL MOTION

G90 and **G91** are used to select absolute (**G90**) or incremental (**G91**) motion. **G90** is the only command allowing absolute positioning.

4.7 FEED RATES

The feed rate display ranges between 00.001 and 270.000 preceded by an **F**. It displays the feed rate that will be used for the selected step. The feed rate corresponds to degrees rotated per second. A feed rate of 270.000 means the spindle will rotate 270 degrees (270°) in one second.

4.8 LOOP COUNTS

Loop Counts allow you to repeat a step up to 999 times before going on to the next step. The loop count display is three digits between 1 and 999 preceded by an **L**. In RUN mode, it displays the remaining loop counts for the selected step. It is also used in conjunction with the **Circle Division** function to enter the number of divisions in the circle from 2 to 999. Used in conjunction with G96, the **Loop Count** specifies the number of times you wish to repeat that subroutine.



4.9 SUBROUTINES (G96)

Subroutines allow you to repeat a particular step sequence up to 999 times. A subroutine is invoked by entering **96** into the G code. After entering **96** you must DISPLAY SCAN over to the LOC (short for location) register to enter the step you wish to jump to. The location register replaces the feed rate register and is only present on **G96** steps. After executing a **G96** step, the control will jump to the step called out in the LOC register, execute that step and the ones following until it reaches G code 95 or 99, the end of subroutine call. The program then jumps back to the step following **G96**.

A subroutine can be repeated a number of times by utilizing the loop count of the **G96** step. To end the subroutine, you must insert a G code of 95 or 99 after the last sequence step. A subroutine call is not considered a step by itself since it will always execute itself and the first step of the subroutine. Nesting of subroutine calls is not permitted.

4.10 DELAY CODE (G97)

G97 is used to program a dwell or delay time into a program. **G97** does not pulse the CNC relay at step completion. As an example, programming a **G97** and setting L=10 will produce a 1 second dwell.

4.11 CIRCLE DIVISION (G98)

Circle division is selected with a **G98**. The L count defines how many equal sized parts a circle is to be divided into. After the L count steps, the servo will be in the same position as it started. Circle division is only available in the circular modes (i.e., Parameter 12=0, 5, or 6).

4.12 AUTO CONTINUE CONTROL

If Parameter 10 is set to 2, the controller can be run like a single axis CNC. The entire program will be executed until the last step is encountered. In all cases, the last step is the one with a **G99**. Actually, the step preceding the **G99** is the last one to be executed. Step **99** may also be the last step if all of memory is used. When running automatically, the sequence of step operation can be stopped by pressing and holding the CYCLE START button until the current step is finished. The program can then be continued by pressing CYCLE START again.

4.13 INSERTING A LINE

A new step may be inserted into a program by pressing and holding the START button for three seconds while in PROGRAM mode. It will cause the present step and all following steps contents to be moved down and cause that step to be initialized to default values. All subroutine jumps are also renumbered.

4.14 DELETING A LINE

A step may be deleted from a program by pressing and holding the ZERO RETURN button for three seconds while in PROGRAM mode. It will cause the next step and all following steps to be moved up by one. All subroutine jumps are also renumbered.



4.15 DEFAULT VALUES

For all steps, the default values are:

000.000 (step size zero)
F (maximum feed rate defined by parameters)
L 001
G 91 (incremental)

If an entry is cleared or set to 0 by the operator, the controller will be set to the default value. All entries are stored when selecting the next display function, step number, or returning to **RUN** mode.

4.16 SELECTING A STORED PROGRAM

There can be more than one stored program, and selection of that program is done by pressing the minus key while showing a G code in PROGRAM mode. The display will change to:

Prog n

Press a number key to select a new program and then press the MODE key to return to RUN mode or the START key to continue with the PROGRAM mode. There are seven programs available, numbered 0 to 6.

4.17 CLEARING A PROGRAM

To initialize or clear a stored program (not including parameters), go to PROGRAM mode (press the MODE button if displays are not blinking) and press and hold the CLR button for three seconds. The displays will cycle through all 99 steps and set all but the first to G99. The first step is set to G91, step size of 0, maximum feed rate, and a loop count of 1.

4.18 OPERATING HINTS

1. You can select another display while in the RUN mode by pushing the DISPLAY SCAN button. This way you could view the particular feed rate for a step or view the remaining loop counts left.
2. You can start your program on any step by using the UP/DOWN scan keys.
3. Make sure your CNC has the same number of **M** functions programmed as you have steps in the HAAS control.
4. Do not program two **M** functions one directly after another in your CNC control to index the HAAS control as this may cause a timing hang up in your CNC. Use a dwell of 1/4 second between them.
5. If all else fails, read the manual again.

4.19 SIMULTANEOUS ROTATION AND MILLING

G94 can be used to perform simultaneous milling. The CNC relay is pulsed at the beginning of the step so that your NC machine will proceed to the next block. The controller then executes the following **L** steps automatically without waiting for start commands. Normally the **L** count on the **G94** is set to 1 and that step is followed by a step that is to be run simultaneously with an NC mill.

**4.20 SPIRAL MILLING**

The simultaneous rotation and milling feature of the controller will permit machining of certain cam forms, spiral, and angular cuts. Spiralmilling is when the spindle rotates and an axis on your mill moves at the same time. Insert a **G94** into the control and the desired rotation and feed rate on the next step. The control will execute **G94** (this pulses the MFIN relay and allows your CNC to proceed) and the following step or steps as one step. If you wish to do more than one step, insert the number into the L register. By selecting a rotation feed rate and varying the mill feed rate any spiral is possible. To spiral mill, you will have to calculate the feed rate for your mill so the HAAS spindle and your axis will stop at the same instant.

To calculate the feed rate for your mill you need to know:

1. The angular rotation of the spindle (this should come from the print)
2. A feed rate for the spindle (arbitrarily select a reasonable one, **five degrees** (5°) per second is a good starting point)
3. The distance you wish to travel on X-axis (this should come from the print)

For example, if we wish to mill a spiral that is **72 degrees** (72°) of rotation and moves 1.500 inches on the X-axis at the same time.

1. Compute the amount of time it will take the HAAS index head to rotate through the angle.

of degrees /(divided by) feed rate of spindle = time to index

72 degrees/ 5 degrees per sec = 14.40 seconds for indexing head to rotate

2. Now we need to compute the feed rate for the mill that will travel the X distance in 14.40 seconds

(length to travel in inches/(divided by) # of seconds of rotation) x 60 seconds = feed rate for mill in inches per minute.

1.500 inches/14.4 seconds = 0.1042 inches per second x 60 = 6.25 inches per minute.

Therefore, if you set the indexer to step **72 degrees** (72°) at a feed rate of **five degrees** (5°) per second you will have to program your mill to travel 1.500 inches at a feed rate of 6.25 inches per minute for the spiral to be generated.

The program for the HAAS control would be as follows:

STEP	STEP SIZE	FEED RATE	LOOP COUNT	G CODE
01	0	270.000	1	[94]
02	[72000] [5.000]	1	[91]	
03	0	270.000	1	[88]
04	0	270.000	1	[99]

The program for your mill would generally look like this:

```

N1 G00 G91      (rapid in incremental mode)
N2 G01 F10. Z-1.0 (feed down in Z axis)
N3 M21         (to start indexing program above at Step 1)
N4 X-1.5 F6.25 (index head and mill move at same time here)
N5 G00 Z1.0    (rapid back in Z axis)
N6 M21         (return indexer home at Step 3)
N7 M30

```

4.21 POSSIBLE TIMING PROBLEMS

When the HA5C executes a **G94**, a 250 millisecond delay is required before executing the following step. This may (it usually doesn't) cause your axis to move before the table rotates leaving a flat spot in the cut. If this is a problem, a solution is to insert a G04 dwell (from 0 to 250 milliseconds) in your CNC after the M function to prevent axis movement. By selecting the right dwell, the HA5C and your mill should start moving at the same instant.

In the same manner, a problem may exist at the end of the spiral, but this can be eliminated by slightly altering the feed rate on your mill. Don't adjust the feed rate on the HAAS control because your mill has a much finer feed rate adjustment than the HAAS control. If the undercut appears to be in the X-axis direction, then speed up slightly (.1 change in feed rate) your mill's feed rate. If the undercut appears in the radial direction of the spindle of the indexer, slow down your mill's feed rate.

If the timing is off by several seconds such that your mill completes movement before the indexer completes its movement, and you have several spiral moves one right after another (such as in retracing a spiral cut), this may cause your CNC to stop for no reason. The reason for this is your CNC will send a cycle start signal (for next cut) to the HAAS control before it has completed its first move thereby causing a timing hang-up. The HAAS control will not accept another cycle start until it is finished with the first. If you are doing multiple moves, it is very important to check your timing calculations. A way to verify if this is actually the problem is to single block your control allowing five seconds between steps. If you can single block the control but it will not successfully run in the continuous mode, then your timing is off somewhere.



5. PROGRAMMING EXAMPLES

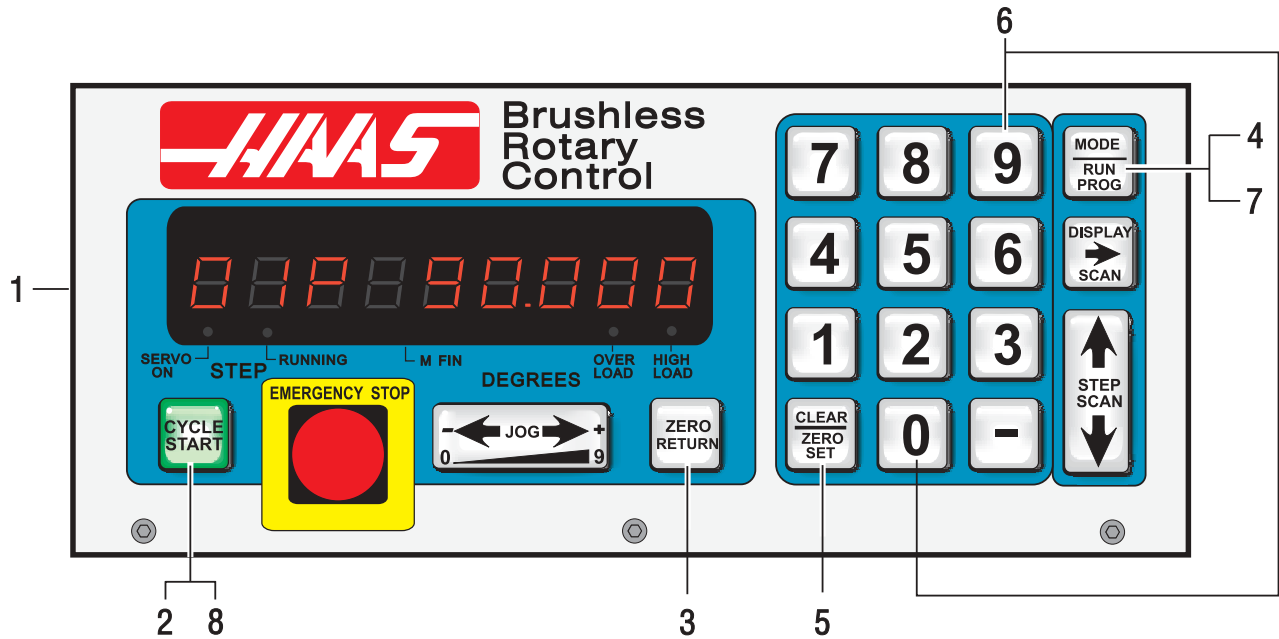

Example #1

We want the indexing head to index **90 degrees** (90°).

- 1) Turn **[POWER]** switch on (back panel).
- 2) Push the **[CYCLE START]** switch.
- 3) Push the **[ZERO RETURN]** switch.
- 4) Push the **[MODE]** button and release. Displays must be blinking.
- 5) Push and hold **[CLR]** button for five seconds. "01 000.000" is displayed.
- 6) Enter **[9 0 0 0 0]**
- 7) Push **[MODE]** button. Steady displays.
- 8) Push **[CYCLE START]** to index.



Example #2

Continuing the previous example, you want the indexing head to index **90 degrees** (Step 1), rotate at 5 degrees/sec (F5) in the opposite direction for **10.25 degrees** (Step2), then return home (Step 3).

(You must have done Example #1 before doing #2)

- 9) Push the **[MODE]** button. Displays blinking.
- 10) Push the **[DOWN ARROW]** once. You should be on Step 2.
- 11) Enter **[- 1 0 2 5 0]** on the key pad. Use CLR if you make a mistake.
- 12) Push the **[DISPLAY SCAN]** button once.
- 13) Enter **[5 0 0 0]** on the keypad.
- 14) Push the **[DISPLAY SCAN]** button twice. A "g 91" will be displayed.
- 15) Push the **[DOWN ARROW]** once. You should be on Step 3.
- 16) Enter **[8 8]** on the keypad.
- 17) Push the **[UP ARROW]** twice. You should be on Step 1.
- 18) Push the **[MODE]** button. Steady displays.
- 19) Push the **[CYCLE START]** switch three times. The table should index **90 degrees** (90°), slow feed in the opposite direction for **10.25 degrees** (10.25°), and return home.

Assuming you have successfully completed the previous two examples, the following examples will show the program as you would enter it into the control. The visual aid of the front panel will not be used. We will assume each time that you have cleared out the memory. The bold face type surrounded by [] indicates data that you would enter into the controller.

Example #3

We want to drill a four-hole pattern and then drill a five-hole pattern on the same part.

STEP	STEP SIZE	FEED RATE	LOOP COUNT	G CODE
01	[90.000]	270.000	[4]	[91]
02	[72.000]	270.000	[5]	[91]
03	0	270.000	1	[99]

Example #3 could have also been done using Circle Division.

STEP	STEP SIZE	FEED RATE	LOOP COUNT	G CODE
01	0	270.000	[4]	[98]
02	0	270.000	[5]	[98]
03	0	270.000	1	[99]

**Example #4**

We want to index **90.12 degrees** (90.12°) and then start a seven-hole bolt pattern and then return back to our zero position.

STEP	STEP SIZE	FEED RATE	LOOP COUNT	G CODE
01	[90.120]	270.000	1	[91]
02	0	270.000	[7]	[98]
03	0	270.000	1	[88]
04	0	270.000	1	[99]

Example #5

We want to index **90 degrees** (90°), slow feed for **15 degrees** (15°), repeat this pattern three times and return home.

STEP	STEP SIZE	FEED RATE	LOOP COUNT	G CODE
01	[90.00]	270.000	1	[91]
02	[15.00]	[25.000]	1	[91]
03	[90.00]	270.000	1	[91]
04	[15.00]	[25.000]	1	[91]
05	[90.00]	270.000	1	[91]
06	[15.00]	[25.000]	1	[91]
07	0	270.000	1	[88]
08	0	270.000	1	[99]

This is the same program (#5) using subroutines.

STEP	STEP SIZE	FEED RATE	LOOP COUNT	G CODE
01	0	LOC [4]	[3]	[96]
02	0	270.000	1	[88]
03	0	270.000	1	[95]
04	[90.00]	270.000	1	[91]
05	[15.00]	[25.000]	1	[91]
06	0	270.000	1	[99]

Explanation:

Step #1 tells the control to jump to Step #4. The control will do Steps #4 and #5 three times, with Step #6 marking the end of the subroutine. After finishing the subroutine, the control jumps back to the step following the "G96" call (in this case, Step #2). Since Step #3 is not part of a subroutine, it marks the end of program and will return the control to Step #1.

Using subroutines in Example #5 only saves two lines of programs. However, if you wanted to repeat the pattern eight times, you would save twelve program lines. In the subroutine example, only the loop count in Step #1 would be changed to increase the number of times you wish to repeat the pattern.



As an aid in programming subroutines, think of the subroutine as a separate program and write it on a separate piece of paper. Program the control using "G96" when you want to invoke the previously written subroutine. When finished, end the program with an End 95 code. Now enter your subroutine and note the step it begins with. Enter that step in the LOC register of the "G96" call.

Example #6

You wish to index 15, 20, 25, 30 degrees in sequence four times and then drill a five-hole bolt pattern.

STEP	STEP SIZE	FEED RATE	LOOP COUNT	G CODE
01	0	Loc [4]	[4]	[96]
02	0	270.000	[5]	[98]
03	0	270.000	1	[95]
(main program above-----subroutine below)				
04	[15.000]	270.000	1	[91]
05	[20.000]	270.000	1	[91]
06	[25.000]	270.000	1	[91]
07	[30.000]	270.000	1	[91]
08	0	270.000	1	[99]



6. PROGRAMMABLE PARAMETERS

There are 37 stored parameters (46 for the brushless units) associated with each servo controller. There is a battery in the controller that will keep the parameters (and the stored program) saved for up to eight years. These parameters are used to change the way the controller and servo loop operate. To change a parameter, go to the PROGRAM mode by pressing the MODE button if not already in PROGRAM mode. Then press the **up** arrow and hold it at step 1 for three seconds. After three seconds, the display will change to the parameter entry mode. The display will indicate:

01 PP.nnnnn

For brushless units the display will indicate:

01U.nnnnnn

where **n** is the value of Parameter 1. Parameters are one to five digits in length and are decimal integers. If changing parameters associated with the servo loop, it is safest to do this with the servo loop off. Turn the servo loop off by pressing EMERGENCY STOP. To exit from parameter entry mode, either press the MODE button to go to RUN mode or push the **down** arrow key until you return to step 1.

The **up** arrow key is used to select the next higher numbered parameter and the **down** arrow key is used to select the next lower numbered parameter. Pressing the **up** arrow, **down** arrow, or MODE keys will cause an entered parameter to be stored.

Most parameters have particular values to which they must be assigned to gain an intended result. There are several parameters, however, which give numbers to add, such as +1. With these parameters, start at zero and add the value for each option you would like.

Some of the parameters are protected from being changed by the user. This is because they could result in unstable or unsafe servo operation. If you need to change any of these parameters, call HAAS Automation.



6.1 GEAR COMPENSATION

This control can store a compensation table to correct for small errors in the worm gear. The gear compensation tables are part of the parameters. While parameters are displayed, press the **right** arrow button to select the gear compensation tables. There is a separate plus (+) direction table from the minus (-) direction table. Use the **right** arrow button to display the plus or minus table. The gear compensation data is displayed as:

gP Pnnn cc for plus table
g- Pnnn cc for minus table

The **nnn** value is the machine position in degrees and the **cc** is the compensation value in encoder steps. There is a table entry every two degrees starting at 001 and going to 359. If your control has non-zero values in the gear compensation tables, it is recommended that you do not change them.

When the gear compensation tables are displayed, the **up** and **down** arrow button will select the next two degree (2°) entry and the minus (-) and numeric buttons will enter a new value. In addition to this the JOG button may be used to adjust the compensation value. If the servo is on when changes are made, the servo motor will move by the adjustment amount if the table is at the position corresponding to the entry changed. This is valuable in that the JOG button can be used to move the motor to a desired position.

Clearing of parameters will set all the gear compensation tables to zero. To exit the gear compensation display, press the MODE button; this returns the control to RUN mode.

When an indexer is using gear compensation, the values in Parameter 11 must be set to "0".

6.2 PARAMETER LIST

The programmable parameters are as follows:

If the brush software ranges are different, they will be shown in parentheses.

Parameter 1: CNC interface relay control, range 0 to 2

- 0: relay active during indexer motion
- 1: relay pulsed for ¼ second at end of motion
- 2: no relay action

Parameter 2: CNC interface relay polarity & AUX. Relay enable, range 0 to 3

- 0: normally open
- +1: normally closed
- +2: optional relay number 2 pulsed at end of program

Parameter 3: servo loop proportional gain, range 0 to 255 PROTECTED!

Servo loop proportional gain increases current in proportion to the proximity to the target position. The farther from the target, the greater the current up to the maximum value in parameter 40. A mechanical analogy is a spring that will oscillate past the target unless dampened by the Derivative gain.

Parameter 4: servo loop derivative gain, range 0 to 99999255 (0 to 255) PROTECTED!

Servo loop derivative gain resists motion effectively braking oscillations. This parameter is increased in proportion to the p gain.

Parameter 5: Double remote trigger option, range 0 to 1

When this parameter is set to 1, the remote start must be triggered twice to activate the control. When it is zero, each activation of the remote input will trigger a step.

Parameter 6: Disable front panel start, range 0 to 1

When this parameter is set to 1, the front panel START and HOME buttons will not work.



Parameter 7: Memory protection, range 0 to 1

When this parameter is set to 1, no changes can be made to the stored program. This does not prevent the changing of parameters.

Parameter 8: Disable remote start, range 0 to 1

1: The remote start input will not work

Parameter 9: Encoder steps per programmed unit, range 0 to 999999 (1 to 65535)

This Parameter defines the number of encoder steps required to complete one full unit (degree, inch, millimeter, etc).

Example: An HA5C with a 2000 pulse per revolution encoder (with four pulses per line, or quadrature) and a 60:1 gear ratio would be $(8000 \times 60) / 360 \text{ degrees} = 1333.333$ encoder steps. Since 1333.333 is not a whole integer, it must be multiplied by some number to clear the decimal point. Use parameter 20 to accomplish this in the above case. Set parameter 20 to 3, therefore: $1333.333 \times 3 = 4000$ (entered in parameter 9).

Parameter 10: Auto continue control, range 0 to 3

- 0: Stop after each step
- 1: Continue all looped steps and stop before next step
- 2: Continue all programs until end code 99 or 95
- 3: Repeat all steps until stopped manually

Parameter 11: Reverse direction option, range 0 to 3 PROTECTED!

This parameter consists of two flags used to reverse the direction of the motor drive and encoder. Start with a zero and add the number shown for each of the following selected options:

- +1: Reverse the direction of positive motor motion
- +2: Reverse the polarity of motor power

Changing both flags to the opposite state will reverse the direction of motor motion.

Parameter 12: Display units and precision decimal location, range 0 to 6

- 0: degrees and minutes (circular) Use this setting to program four digits of degrees up to 9999 and two digits of minutes
- 1: inches to 1/10 (linear)
- 2: inches to 1/100 (linear)
- 3: inches to 1/1000 (linear)
- 4: inches to 1/10000 (linear)
- 5: degrees to 1/100 (circular) Use this setting to program four digits of degrees up to 9999 and two digits of fractional degrees to 1/100
- 6: degrees to 1/1000 (circular) Use this setting to program three digits of degrees up to 999 and three digits of fractional degrees to 1/1000

Parameter 13: Maximum positive travel, range 0 to 99999 (1 to 65535)

This is the positive travel limit in units*10 (entered value loses last digit). It applies only to linear motion (i.e., Parameter 12=1, 2, 3, or 4). If it is set to 1000, positive travel will be limited to 100 inches. The entered value is also affected by the gear ratio divider (parameter 20).

Linear Example (6mm pitch ballscrew): 20.0 inch travel X 138718 ratio = 2774360 (entered value: 277436)

Rotary Example (must also use "linear" settings of 1,2,3 or 4 entered in parameter 12): 120.0 degrees of travel X 4000 ratio = 480000 (entered value: 48000)

Rotary Example (with a parameter 20 value of 3): 120.0 degrees of travel x 4000 ratio/3 = 160000 (entered value: 16000).



Parameter 14: Maximum negative travel, range 0 to 99999 (0 to 65535)

This is the negative travel limit in **units*10** (entered value loses last digit). It applies only to linear motion (i.e., Parameter 12=1, 2, 3, or 4). For examples see parameter 13.

Parameter 15: Backlash amount, range 0 to 99

This parameter is used to compensate electronically for mechanical gear backlash. It is in units of encoder steps. Note: this parameter cannot correct mechanical backlash.

Parameter 16: Auto continue dwell, range 0 to 99

This parameter causes a pause at the end of a step when the automatic continuation option is used. The delay is in multiples of 1/10 second. Thus, a value of 13 will give 1.3 seconds of delay. Used primarily for continuous duty, allowing motor cool down time for longer motor life.

Parameter 17: servo loop integral gain, range 0 to 255 PROTECTED!

Servo loop integral gain. In addition to the range of 0 to 255, if the integral is to be disabled during deceleration (for less overshoot), set Parameter 24 accordingly. Integral gain provides larger increases of current to achieve target. This parameter, set too high, will often cause a hum.

Parameter 18: Acceleration, range 0 to 999999x100 (0 to 30000) PROTECTED!

This parameter defines how fast the motor is accelerated up to the desired speed. The value used in **(Par 18)*100** in encoder steps/second/second. The highest acceleration is thus 3000000 steps per second per second. It must be greater than or equal to Parameter 19, usually 2X. Lowering this value results in gentler acceleration.

Parameter 19: Maximum speed, range 0 to 999999x100 (0 to 10000)

This parameter defines the maximum speed (RPM of motor). The value used is **(Par 19)*100** in encoder steps/second. The highest speed is thus 1000000 steps per second. It must be less than or equal to Parameter 18. If this parameter exceeds Parameter 36, only the smaller number is used. See Parameter 36 also. The entered value = the desired value/parameter 20 if a gear ratio divider is used. Lowering this value results in reduced maximum speed (motor maximum RPM).

Standard Formula: degrees (or inches) per sec X ratio (parameter 9) / 100 = entered value in parameter 19.

Formula with Gear Ratio Divider (parameter 20): degrees (or inches) per second X ratio (parameter 9)/ [ratio divider (parameter 20) x 100] = entered value in parameter 19.

Parameter 20: Gear ratio divider, range 0 to 100 PROTECTED!

This parameter can be used to select non-integer gear ratios for Parameter 9. If Parameter 20 is set to 2 or more, Parameter 9 is divided by Parameter 20 before it is used. As an example, if Parameter 9=2000 and Parameter 20=3, the number of steps per unit will be 2000/3 = 666.667. Thus compensating for fractional gear ratios. If this parameter is set to 0 or 1, no change is made to the Parameter 9 value.

Example 1: Parameter 9=2000 and Parameter 20=3, the number of steps per unit will be 2000/3 = 666.667.

Example 2 (with a gear ratio divider parameter 20 needed):

32768 (brushless) encoder pulses per revolution x 33:1 gear ratio/360 degrees per revolution = 3003.7333 since 3003.7333 is non integer, we require a ratio divider (parameter 20) set to 15 then:
3003.7333 = 45056 (parameter 9) encoder steps/15 (parameter 20) ratio divider.

Parameter 21: RS-232 interface axis select, range 0 to 9

When this parameter is zero, no remote RS-232 functions are available. This parameter must be set to zero when up/down loading programs. When it is 1 to 9, that number is used to define the axis code for this controller. U is 1, V is 2, W is 3 X is 4, Y is 5, and Z is 6. 7 through 9 are other ASCII character codes.



Parameter 22: Maximum allowed servo loop error, range 0 to 4000 PROTECTED!

When this parameter is zero, no maximum error limit test is applied to the servo. When it is non-zero, that number is the maximum allowed error before the servo loop is turned off and an alarm generated. This auto shut-off results in a display of: **Ser Err**

Parameter 23: Fuse level in %, range 0 to 100 PROTECTED!

This parameter is used to define a fuse level for the servo control loop. The value is a percentage of maximum power level available to the controller. It has an exponential time constant of about 30 seconds. If exactly the set level is output by the driver continuously, the servo will shut off after 30 seconds. Twice the set level will shut the servo off in about 15 seconds. This parameter is factory set and is usually set from 25% to 35% depending on the product. This auto shut-off results in a display of: **Hi LoAd.**

Warning! Changes from HAAS recommended values will damage the motor.

Parameter 24: General purpose flags, range 0 to 1023 PROTECTED!

This parameter consists of five individual flags for controlling servo functions.

- +1: Interpret Parameter 9 as twice entered value
- +2: Disable integral while decelerating (see Parameter 17)
- +4: Disable integral when brake is engaged (see Parameter 17)
- +8: Protection of parameters enabled (see Parameter 30)
- +16: Serial interface disabled
- +32: Start-up "HAAS" message disabled
- +64: Lower lag in compensation
- +128: Disable Z channel encoder test
- +256: Normally closed overtemp sensor
- +512: Disable cable test

Parameter 25: Brake release time, range 0 to 19 PROTECTED!

If this parameter is zero, the brake is not activated (i.e., always engaged); otherwise this is the delay time to release the air before the motor is started in motion. It is in units of 1/10 second. A 5 will thus delay for 5/10 second. This parameter is not used in a HA5C and defaulted to 0.

Parameter 26: RS-232 speed, range 0 to 8

This parameter is used to select data rates on the RS-232 interface. The parameter values and rates are:

- | | | | |
|----|------|----|-------|
| 0: | 110 | 5: | 4800 |
| 1: | 300 | 6: | 7200 |
| 2: | 600 | 7: | 9600 |
| 3: | 1200 | 8: | 19200 |
| 4: | 2400 | | |

**Parameter 27:** automatic home control, range 0 to 512 (0 to 255) PROTECTED!

All HAAS Indexers use a home switch used in conjunction with the Z pulse on the motor encoder (one for each revolution of the motor) for repeatability. The home switch consists of a magnet (Haas PN 69-18101) and proximity switch (Haas PN 36-3002), which is of the magnetically sensitive transistor type. When the control is shut down and restarted, it will give a “no home” display, requiring the user to press the “zero return” button. The motor then operates slowly in a clockwise direction (as viewed from the platter of a rotary table) until the proximity switch is magnetically tripped and then backs up to the first Z pulse. (See parameter code options in parameter section for actual options.) Note: to reverse direction when seeking a home switch (if it currently moves away from the home switch during the home sequence), add 256 to the value in parameter 27.

This parameter is used to customize the home control function of servo.

- 0: no automatic home functions available (no home switch)
- 1: only table zero position switch available
- 2: only Z channel home available
- 3: home on both Z channel and table zero switch
- +4: home if inverted Z (determined by encoder used)
- +8: home to zero position in negative direction
- +16: home to zero position in positive direction
- +24: home to zero position in shortest direction
- +32: auto servo on at power on
- +64: auto search for home at power on (have “auto servo on at power up” selected)
- +128: for inverted HOME switch (determined by home switch used)
- +256: search for home in positive direction (Brushless only)

Parameter 28: encoder steps per motor revolution, 0 to 99999 (0 to 10000) PROTECTED!

This parameter is used with the Z channel option to check the encoder accuracy. If Parameter 27 is 2 or 3, this parameter is used to check that the correct number of encoder steps are received per revolution.

Only two numbers are used here: **32768** for all brushless motors (8192 line encoder x quadrature)
 8000 for all brush motors (2000 line encoder x quadrature)

Parameter 29: Back-EMF compensation, range 0 to 999 PROTECTED!

This parameter is used to control the adjustment of loop gain in response to motor generated back-EMF. It is **volts/Krpm times 10**. Thus if the motor has 24.6 volts per KRPM this parameter is set to 246.

Parameter 30: Protection, range 0 to 65535

This parameter is used to protect some of the other parameters. Every time the controller is turned on, this parameter will have a new, random, value. If protection is selected (Parameter 24), the protected parameters cannot be changed until this parameter is set to a different value that is a function of the initial random value.

Parameter 31: CNC Relay Hold Time, range 0 to 9

This parameter is used to specify the amount of time the CNC interface relay is held active at the end of a step. If zero, the relay time is ¼ second. All other values give the time in multiples of 0.1second.

Parameter 32: Delay time for engaging brake, range 0 to 9 PROTECTED!

This parameter is used to set to amount of time delay between the end of a motion and engaging the air brake. It is a unit of 1/10 seconds. A “4” will thus delay for 4/10 second.

Parameter 33: X-on/X-off Enable, 0 or 1

This parameter is used to enable the sending of the X-on and X-off codes via the RS-232 interface. If your computer needs these, this parameter should be set to 1. Otherwise, only the RTS and CTS lines can be used to synchronize communication. (See section 2.7 on RS-232 Interface.)



Parameter 34: Belt stretch adjustment, range 0 to 99 PROTECTED!

This parameter is used to correct for stretching in a belt if one is used to couple the motor to the load being moved. It is a count of the number of steps of motion that are added to the motor position while it is moving. It is always applied in the same direction as the motion. Thus, when motion stops, the motor will snap backwards to take the load off the belt. This parameter is not used in a HA5C and defaulted to 0.

Parameter 35: Dead zone compensation, range 0 to 19 PROTECTED!

This parameter is used to compensate for the dead zone in the driver electronics. It is normally set to 0.

Parameter 36: Maximum speed, range 0 to 10000 (0 to 999999x100) PROTECTED!

This parameter defines the maximum speed. The value used is **(Par 36)*100** in encoder steps/second. The highest speed is thus 1000000 steps per second. It must be less than or equal to Parameter 18. If this parameter exceeds Parameter 19, only the smaller number is used. See Parameter 19 also.

Parameter 37: Encoder test window size, range 0 to 999

This parameter defines the tolerance window for the Z channel encoder test. This much error is allowed in the difference between the actual encoder position and the ideal value when the Z channel is encountered.

The following parameters are for brushless motors:

Parameter 38: KDD 0 to 9999 (not used in brush units)

Servo loop second differential gain.

Parameter 39: Phase offset 0 to 9 (not used in brush units)

Offset of encoder Z-pulse to zero degree of phasing.

Parameter 40: Max current 0 to 2047 (not used in brush units)

Maximum peak current output to the motor. Units DAC bits.

Warning! Changes to this parameter from HAAS recommended values will damage the motor.

Parameter 41: Not used 0 to 537289 (not used in brush units)

Parameter 42: KLAG 0 to 3 (not used in brush units)

Filter coefficient for the output current.

0 is 0% of 65536

1 is 50% of 65536 or 0x8000

2 is 75% of 65536 or 0xC000

3 is 7/8 of 65536 or 0xE000

Parameter 43: EREV PER MREV 1 to 9 (not used in brush units)

Number of electrical revolutions of the motor per one mechanical revolution.

Parameter 44: ACCEL_CONST 0 to 999 (not used in brush units)

Exponential acceleration time constant. Units are 1/10000 seconds.

Parameter 45: Grid Offset 0 to 99999 (not used in brush units)

The distance between the home switch and the final stopped motor position after homing, is added by this grid-offset amount. It is modulus of parameter 28, which means if Parameter 45=32769 and Parameter 28=32768, then it is interpreted as 1.

Parameter 46: Beeper Timing (0 to 999)

Length of beeper tone in milliseconds. 0-35 no tone. Default 150 milliseconds.

Parameter 47: Zero Offset (0-9999) For HRT320FB.

Angular value to offset zero position. Units are 1/1000 of a degree.

Parameter 48: Indexer Increment (0-1000) HRT320FB only

Angular value to control indexer increments. Units are 1/1000 of a degree



7. HA5C TROUBLESHOOTING

7.1 TROUBLESHOOTING A WORKING INTERFACE ON A CNC

If you are having problems with an interface, try to isolate the problem by checking the HAAS control and your CNC separately. There are only two signals and each one can be checked separately from the other. If your unit stops indexing because of an interface problem, here are some simple checks to follow:

1) Check The HAAS Control Remote Input Alone

Disconnect the remote cable from the back of the controller. Set the control to index a single step of **90 degrees** (90°). Referring to Figure 1, connect a continuity tester or a voltmeter (a digital meter may not be fast enough to sample the brief pulse) set for low ohms across pins 1 and 2. They are marked on the rear of the control as FINISH SIGNAL. Since this is a female plug, you may have to insert some small wires in the plug in order to make a connection but, in any case, it is imperative that a good connection is made. It must show open circuit, otherwise check relay Parameters 1 (should be 1) and 2 (should be 0). (With the control turned off the relay must show open circuit otherwise the relay is defective.) Now using a wire jumper short pins 3 and 4 together. (They are marked on the rear of the control as CYCLE START.) The unit must index, and at the end of the index, the voltmeter should deflect briefly towards low ohms or continuity. If this works as described, you know the problem is not in the Haas control but may be in the interface cable or your CNC.

2) Check Your CNC Cable Interface Alone

You can check the signals from the CNC using your voltmeter and keeping in mind that the pin orientation is reversed. Execute an **M** function from your CNC to index. The CNC cycle start light should come on and stay on. Use the meter and check continuity across the cycle start pins (pins 3 and 4). Try not to short your test leads and pins against the shield of the male plug.

NOTE: On rare occasions some machine builders may provide a +12 to +24 volts signal on pin 4 to activate our unit. If the continuity test fails, check and see if there is a voltage present between pin 4 and the machine ground. This is also a valid cycle start signal. If there is a voltage present on Pin 4 when checked with a voltmeter, A Haas interface box must be used (Part # IB). Contact the Haas Service department if there are questions on how to use the interface box.

To check out the cycle finish take one of your voltmeter test probes and short together pins 1 and 2 on your CNC cable. The cycle start light on your CNC should immediately go out.

If the two tests above pass (1 and 2), you have valid signals coming from your CNC.

3) Check the HAAS Control and Your CNC Together

Reset your CNC by hitting the RESET button or turning it off. With the CNC and Haas control ON, connect the remote cable. Nothing should happen. If the HAAS should index, then the cycle start signal from the CNC is shorted on. If OK, execute or MDI an M function from your CNC to index. Don't index from the program unless you are single blocking it. If the HAAS does not index, then your CNC is not outputting a signal, or there is a break in the line.

If the Haas indexes properly, observe that the machine's cycle start light goes out at the end of index. (Make sure that this light isn't burned out.) If the light does not go out, then the cycle finish signal is not getting back to your CNC. This could be an open wire in the remote cable or a problem in wires that connect to the CNC.

If the unit works only in single block, but not in the RUN mode, then you probably having a timing problem involving two **M** functions, or are doing simultaneous milling. Please review the section on simultaneous milling. If you have two **M** functions, separate them with a dwell of 1/4 second.



7.2 HA5C TROUBLESHOOTING GUIDE

SYMPTOM	PROBABLE CAUSES	REMEDY
Unit is turned on but the power switch is not illuminated.	<ul style="list-style-type: none"> ❶ Control is not receiving power. 	<ul style="list-style-type: none"> ❶ Check power cord, line fuse, and AC supply.
Front panel START and ZERO RETURN buttons don't work.	<ul style="list-style-type: none"> ❶ In PROGRAM mode, or Parameter 6 is set to 1. 	<ul style="list-style-type: none"> ❶ Change Parameter 6 to 0. Set to RUN mode.
ERROR displays when trying to program.	<ul style="list-style-type: none"> ❶ Parameter 7 is set to 1. 	<ul style="list-style-type: none"> ❶ Change Parameter 7 to 0.
Lo Volt or Por On appears while running, or erratic operation.	<ul style="list-style-type: none"> ❶ Power available to control is inadequate. 	<ul style="list-style-type: none"> ❶ Power source must be capable of 15 amps at 120V AC. Use shorter/heavier gauge cord.
Indexer runs through entire program without stopping.	<ul style="list-style-type: none"> ❶ Parameter 10 is set to 3. 	<ul style="list-style-type: none"> ❶ Change Parameter 10 to 0.
High current (Hi Curr)	<ul style="list-style-type: none"> ❶ Heavy work load. ❷ Fixture/workpiece is distorted. ❸ Coolant-damaged conduit box. ❹ Shorted motor 	<ul style="list-style-type: none"> ❶ Reduce feed. ❷ Ensure fixture workpiece mounting surface is flat within .001". ❸ Examine conduit box, and replace if damaged. ❹ Consult Haas Service department.
SERVO ERROR: Ser-Err during first home find initiation. Ser-Err upon indexing.	<ul style="list-style-type: none"> ❶ Faulty main cable or cable connector. ❷ Head driving a heavy load. ❸ Head is jammed. 	<ul style="list-style-type: none"> ❶ Check cable Replace if damaged. ❷ Reduce workload weight and/or feed rates. ❸ Eliminate obstruction.
High load (Hi LoAd)	<ul style="list-style-type: none"> ❶ Head is jammed. ❷ Heavy work load. ❸ Fixture / workpiece is distorted. 	<ul style="list-style-type: none"> ❶ Eliminate obstruction. ❷ Reduce feed ❸ Ensure fixture workpiece mounting surface is flat to within .001"
Workpiece chatter during index and continuous cutting operation.	<ul style="list-style-type: none"> ❶ Excessive backlash. ❷ Excessive wormshaft play. 	<ul style="list-style-type: none"> ❶ Consult HAAS Service Dept. ❷ Consult HAAS Service Dept.
Dead length collets sticking, or insufficient clamping force.	<ul style="list-style-type: none"> ❶ Excessive spindle/collet friction. 	<ul style="list-style-type: none"> ❶ Lubricate spindle and collet with a Molybdenum disulfide grease.



8. ROUTINE MAINTENANCE

8.1 USE OF OIL- AND WATER-SOLUBLE COOLANTS

For the use of oil and water soluble coolants, the following guidelines should be observed:

- **DO NOT SUBMERGE THE UNIT IN COOLANT.** Keep the coolant lines on the work piece spraying away from the head. Tool spraying and spatter usually will not be detrimental to the motor but large amounts of pressurized coolant should be directed away from the head. Some machining centers provide flood coolant at enormous rates so that the head is practically submerged. Try to cut the flow down to match the job.
- Inspect the cables and gaskets for cuts or swelling. Damage must be repaired immediately.

8.2 LUBRICATION

To check the lube level of the Rotary Indexer, view the level of lube visible in the eye with the Indexer stopped. The eye is located on the side of the Indexer. The lube level should reach the middle of the eye. If necessary, add lube until the level reaches the mid-point of the eye.

To add lube to the Rotary Indexer, locate and remove the Pipe-plug from the lube fill port. This is located under the handle in the casting (see Figure below). Add Mobil SHC-630 oil until the proper level is reached. Replace the fill port bolt and tighten.

Replace the oil every 2 years.

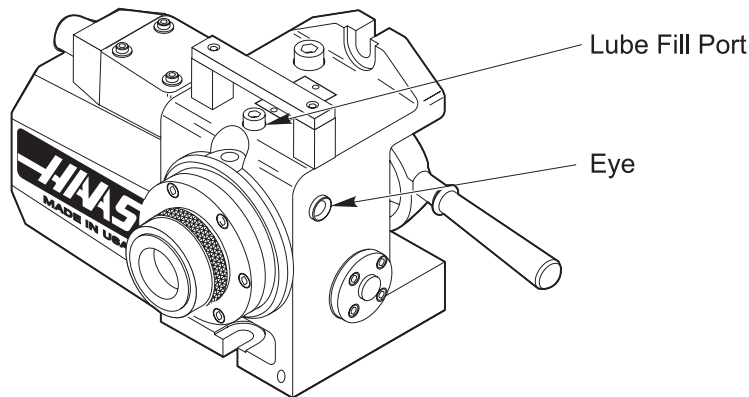

Fill Port Location for Rotary Indexer



8.3 CLEAN UP

At the end of the workday or shift, it is important to clean the rotary table. The head should be free of any chips or grime. Clean with a chip brush and apply a coat of a rust preventative. **Do not use air gun around front or rear seals.** Chips may damage seal if blown in with an airgun.

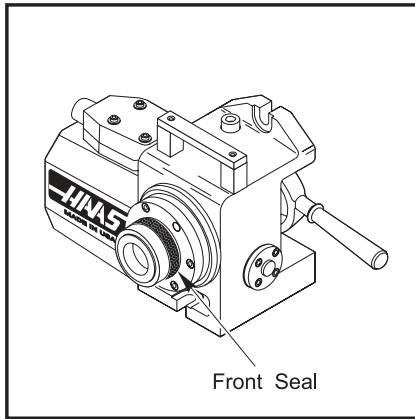

Figure 8.1 Front Spindle Seal

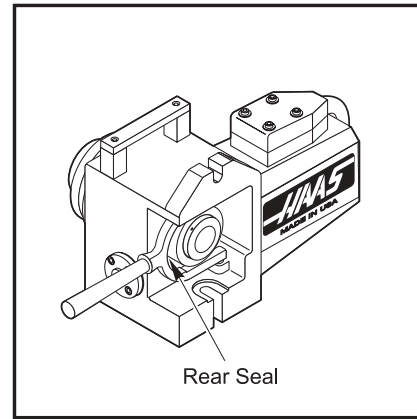
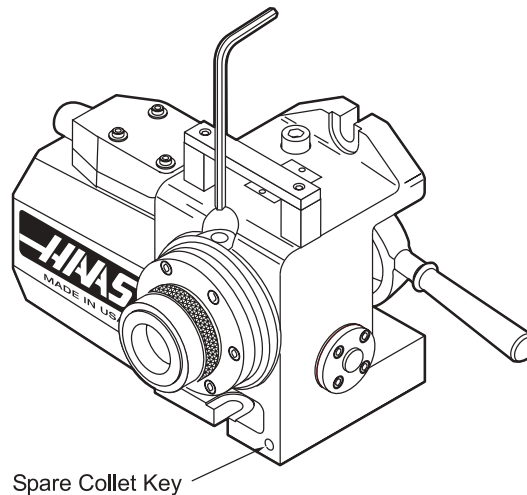

Figure 8.2 Rear Gear Seal

8.4 COLLET KEY REPLACEMENT

Replacing the Collet Key



Remove the pipe plug from the access hole with a 3/16 allen wrench. Align the collet key with the access hole by jogging the spindle with the control box. remove the collet key with a 3/32 allen wrench. Replace the collet key with HAAS P/N 22-4052 only! A spare collet key is located on the front casting face in the bottom right corner. Screw the collet into the spindle until it begins to protude into the inside diameter. Place a new Hardinge collet into the spindle while aligning the keyway with the key. Tighten the key until it hits the bottom of the keyway then back off 1/4 turn. Pull the collet out to make sure it slides freely. Replace the pipe plug back into the access hole.

NOTE: Never run the indexer with the collet key backed out as this will damage the spindle and gall the spindle bore.



9. HA5C ASSEMBLY DRAWING

IT	QTY	P/N	DESC
25	1	35-4000	WORM SHAFT ASSY HA5C
1	1	20-4005	WORM SHAFT HA5C
1	1	20-4007A	BEARING HOUSING WORM HA5C
1	1	20-4015	BEARING NUT
1	1	51-4010	BEARING ANGULAR CONTACT 10X26X6MM
1	1	51-4115	BRNG LOCKNUT BH-00
1	1	57-4100	O-RING 2-024 VITON

IT	QTY	P/N	DESC
1	1	20-2052	SPINDLE NUT (MANCCA)
2	2	22-2060	BUSHING HANDLE (MANCCA)
3	1	22-4019	KEY SPINDLE
4	2	22-5017	LOCATING PIN
5	1	22-2069	DETENT PIN S5C (30-1122)
6	1	20-2072	SPINDLE COVER S5C
7	1	20-4000A	BODY MACHINED INDEX
1	1	35-4057	SPINDLE/SPACER ASSY HA5C
8	1	20-4001A	SPINDLE 5CV
9	1	20-4002A	SPINDLE LOCK
10	1	20-4003	SPINDLE SPACER
11	1	20-4004	WORM GEAR (30-1122)
12	1	69-18103	MAGNET #89 F 1405 (30-1122)
13	1	20-4008	BEARING END CAP
14	1	20-4451	MOTOR MOUNT
15	1	20-4042	BL MOTOR ENCLOSURE
16	2	20-4012	HANDLE BOLT (MANCCA)
17	1	20-4013A	REAR OIL SHIELD 5CV
18	1	20-4014	REMOVABLE HANDLE
19	1	22-4018	DETENT PLUG (30-1122)
20	1	20-4020	TUBE WICK OILER
21	1	59-2869	WICK 1/4 DIA ROUND
22	6	49-4101	WASHER 1/4 COPPER
23	1	35-3050	COLLET HOLDER ASSEMBLY (MANCCA)
24	1	35-3073	INDEXER HANDLE ASSY (MANCCA)
1	1	20-2059	HANDLE COLLET CLOSER
1	1	48-1664	PIN ROLL 3/16 X 5/8
2	2	48-1665	PIN DOWEL 5/16 X 3/4
26	1	36-3002	HOME SWITCH ASSY WP
27	1	36-4031B	BRUSHLESS 04 CABLE WP 14
28	1	62-2495	MOTOR AC SERVO YASKAWA 04
29	6	40-1610	SHCS 1/4-20 X 1
30	1	40-1613	FHCS 4-40 X 3/8
31	8	40-1645	SHCS 10-32 X 5/8
32	4	40-16455	SHCS 10-32 X 7/8
33	4	40-1666	MC DR SCRW 2 X 1/4 RD HD
34	4	40-1798	SHCS 8-32 X 1 3/4
35	2	40-1632	SHCS 1/4-20 X 1 1/2
36	4	40-16205	SHCS 10-32 X 1 3/4
37	4	40-1703	FHCS 10-32 X 1 1/2
38	2	22-4052	COLLET KEY HA5C
39	8	45-1735	WASHER #10 FLAT SAE T18-8
40	1	52-4478	14mm X 12mm CURVED JAW COUPLING
41	4	45-1601	WASHER FLAT
42	1	51-4000	BEARING RADIAL 12X32X10MM
43	1	56-0010	SNAP RING N5000-125
44	2	57-2022	O-RING 2-150 V- 1164-75
45	1	57-2105	O-RING 2-143 V- 1164-75
46	1	57-2235	O-RING 2-032 VITON
47	1	57-4011	MOTOR ENCLOSURE GASKET
48	1	57-4102	O-RING 2-035 V- 1164-75
49	2	57-4110	O-RING 2-045 V- 1164-75
50	2	58-1627	1/8-27 PIPE PLUG
51	1	59-2070	SPRING DETENT (30-1122)
52	1	59-2071	LOCKING PAWL
53	1	20-0732	NAMEPLATE LASER HA5C
54	1	59-2876	SPRING WICK OILER
55	1	59-4110	SIGHT GLASS LSP501-O8RGL
56	2	58-2745	MAGNETIC OIL PLUG
57	1	57-4100	O-RING 2-024 VITON
58	1	57-4130	O-RING 2-138 VITON
59	1	55-4484	WAVE WASHER SSR-0062
60	4	57-0057	O-RING 2-007 VITON
61	1	57-4133	J-BOX GASKET SQUARE
62	1	57-4114	O-RING 2-127 V-1164-75

EX-0017E REV.E MT 11-20-01



Ha5c-Series

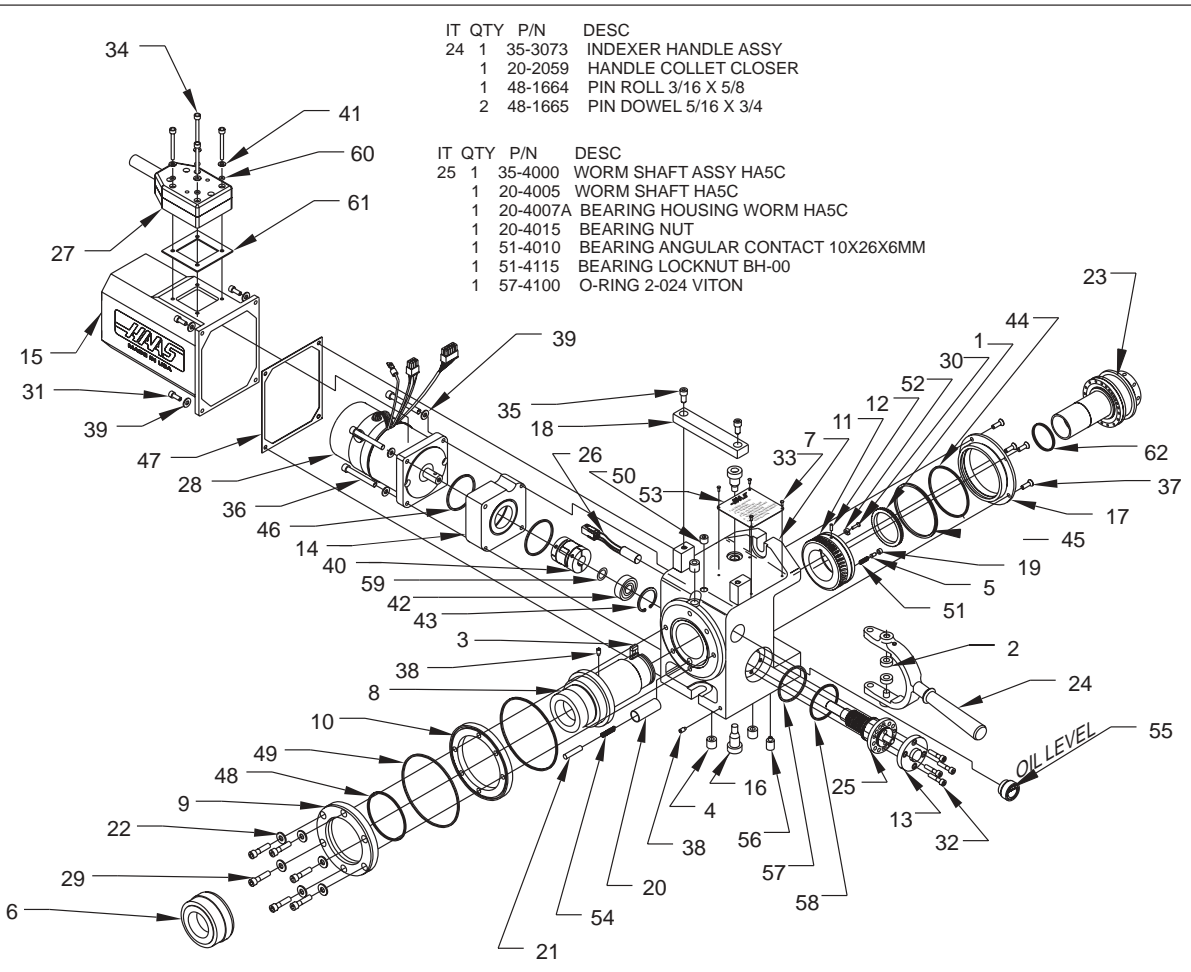

IT	QTY	P/N	DESC
24	1	35-3073	INDEXER HANDLE ASSY
	1	20-2059	HANDLE COLLET CLOSER
	1	48-1664	PIN ROLL 3/16 X 5/8
	2	48-1665	PIN DOWEL 5/16 X 3/4

IT	QTY	P/N	DESC
25	1	35-4000	WORM SHAFT ASSY HA5C
	1	20-4005	WORM SHAFT HA5C
	1	20-4007A	BEARING HOUSING WORM HA5C
	1	20-4015	BEARING NUT
	1	51-4010	BEARING ANGULAR CONTACT 10X26X6MM
	1	51-4115	BEARING LOCKNUT BH-00
	1	57-4100	O-RING 2-024 VITON

IT	QTY	P/N	DESC (TOP LEVEL OF SUBASSY)
1	1	20-2052	SPINDLE NUT (MANCCA)
2	2	22-2060	BUSHING HANDLE (MANCCA)
3	1	22-4019	KEY SPINDLE
4	2	22-5017	LOCATING PIN
5	1	22-2069	DETENT PIN S5C (30-1122)
6	1	20-2072	SPINDLE COVER S5C
7	1	20-4000A	BODY MACHINED INDEX
	1	35-4057	SPINDLE/SPACER ASSY HA5C
8	1	20-4001A	SPINDLE 5CV
9	1	20-4002A	SPINDLE LOCK
10	1	20-4003	SPINDLE SPACER
11	1	20-4004	WORM GEAR (30-1122)
12	1	69-18103	MAGNET #89 F 1405 (30-1122)
13	1	20-4008	BEARING END CAP
14	1	20-4009	MOTOR MOUNT
15	1	20-4010A	MOTOR ENCLOSURE HA5C
16	2	20-4012	HANDLE BOLT (MANCCA)
17	1	20-4013A	REAR OIL SHIELD 5CV
18	1	20-4014	REMOVABLE HANDLE
19	1	22-4018	DETENT PLUG (30-1122)
20	1	22-4020	TUBE WICK OILER
21	1	59-2869	WICK 1/4 DIA ROUND
22	6	49-4101	WASHER 1/4 COPPER
23	1	35-3050	COLLET HOLDER ASSY (MANCCA)
24	1	35-3073	INDEXER HANDLE ASSY (MANCCA)
25	1	35-4000	WORM SHAFT ASSY HA5C
26	1	36-3002	HOME SWITCH ASSY WP
27	1	36-4025B	CONDUIT ASSY ROTARY WP
28	1	36-4175B	ELEC MTR ASSY HA5C WP
29	6	40-1610	SHCS 1/4-20 X 1
30	1	40-1613	FHCS 4-40 X 3/8
31	4	40-1645	SHCS 10-32 X 5/8

IT	QTY	P/N	DESC
32	4	40-16455	SHCS 10-32 X 7/8
33	4	40-1666	MC DR SCR W 2 X 1/4 RD HD
34	4	40-1798	SHCS 8-32 X 1 3/4
35	2	40-1632	SHCS 1/4-20 X 1/2
36	4	40-1700	SHCS 10-32 X 2
37	4	40-1703	FHCS 10-32 X 1/2
38	2	22-4052	COLLET KEY HA5C
39	8	45-1735	WASHER #10 FLAT SAE T18-8
40	1	52-4484	COUPLING 1/2 X 12MM
41	4	45-0042	WASHER FLAT
42	1	51-4000	BEARING RADIAL 12X32X10MM
43	1	56-0010	RETAINING RING N5000-125
44	1	57-2022	O-RING 2-150 V- 1164-75
45	1	57-2105	O-RING 2-143 V- 1164-75
46	2	57-2235	O-RING 2-032 VITON
47	1	57-4011	MOTOR ENCLOSURE GASKET
48	1	57-4102	O-RING 2-035 V- 1164-75
49	2	57-4110	O-RING 2-045 V- 1164-75
50	2	58-1627	1/8-27 PIPE PLUG
51	1	59-2070	SPRING DETENT (30-1122)
52	1	59-2071	LOCKING PAWL
53	1	20-0732	NAMEPLATE LASER HA5C
54	1	59-2876	SPRING WICK OILER
55	1	59-4110	SIGHT GLASS LSP501-O8RG
56	2	58-2745	MAGNETIC OIL PLUG
57	1	57-4100	O-RING 2-024 VITON
58	1	57-4130	O-RING 2-138 VITON (MULTI HEAD)
59	1	55-4484	WAVE WASHER SSR-0062
60	4	57-0057	O-RING 2-007 VITON
61	1	57-4133	J-BOX GASKET SQUARE
62	1	57-4114	O-RING 2-127 V-1164-75

TOP LEVELS
 30-1719 COMPLETE HA5C
 30-1123 HA5CHO UNTESTED

EX-0006J REV.J MT 11-20-01