

8X  $\phi$  .20in [5.1mm] THRU ALL  
 $\perp$   $\phi$  .34in [8.7mm]  $\nabla$  .19in [4.8mm]

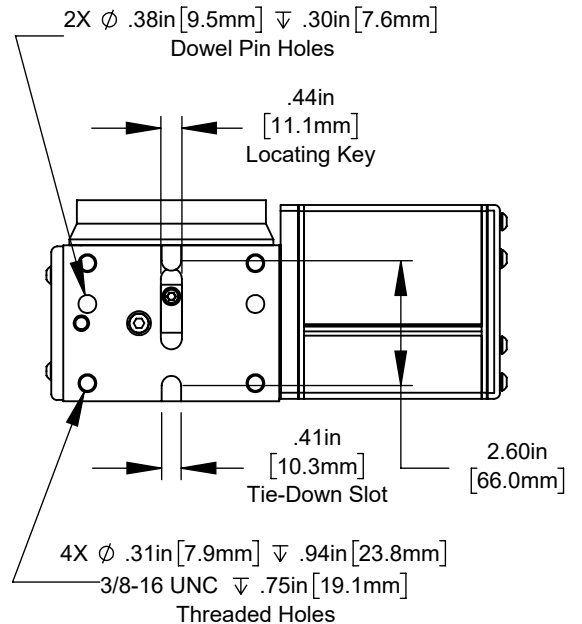

All dimensions based on stackup of sheetmetal, subject to variation of 1/2" ( 13 mm)

\*Due to continual product improvements, machine dimensions are subject to change without notice.

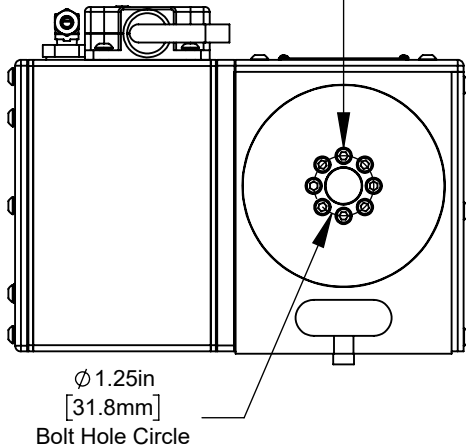
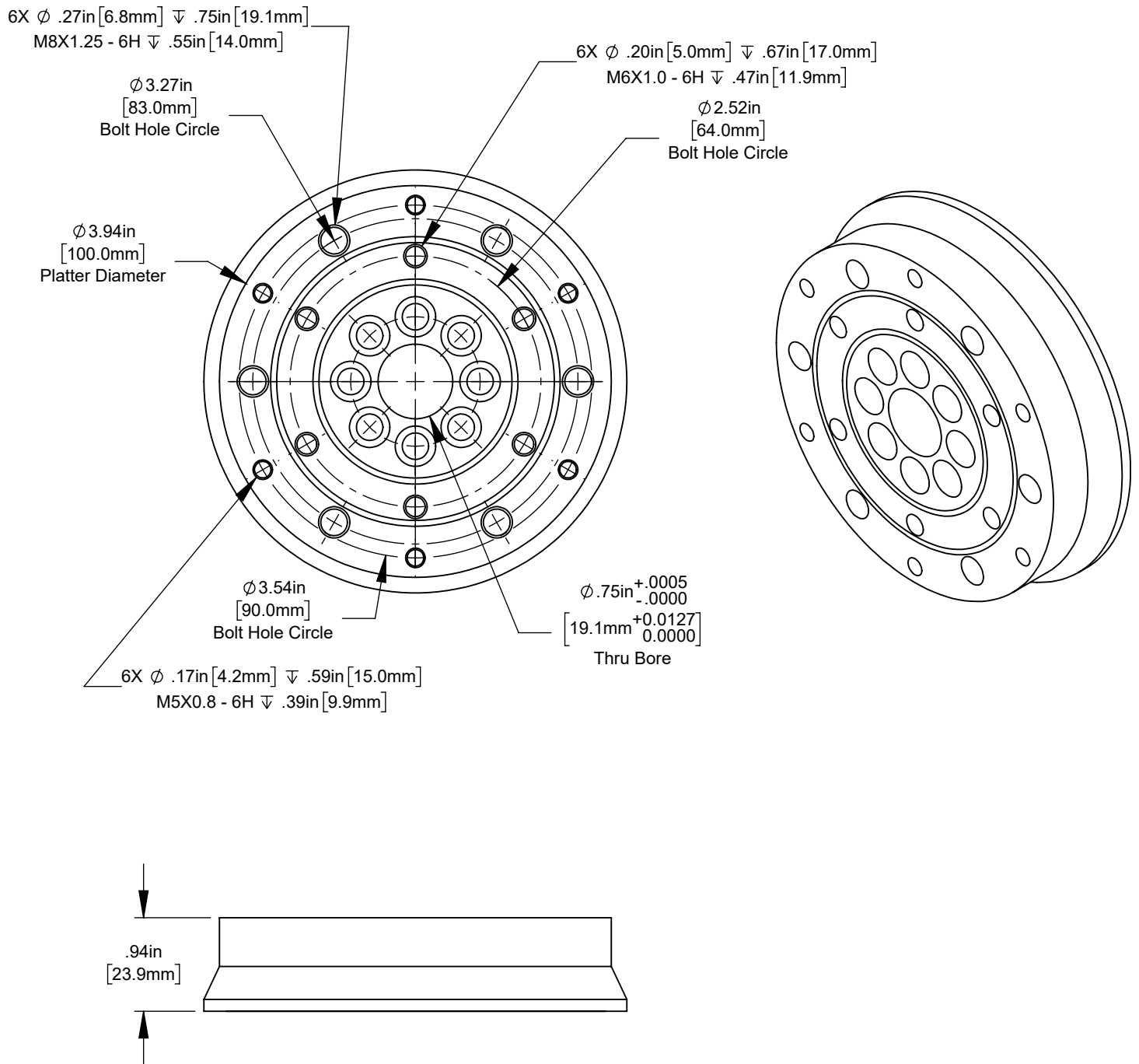

All dimensions based on stackup of sheetmetal, subject to variation of 1/2" ( 13 mm)

\*Due to continual product improvements, machine dimensions are subject to change without notice.