

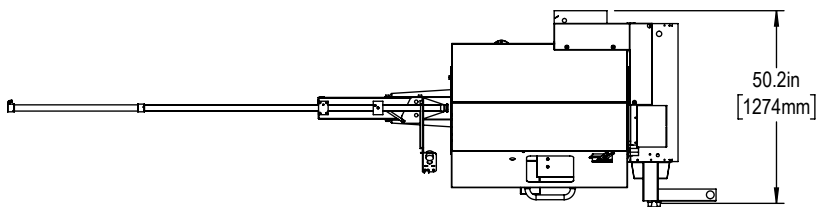

Installed Dimensions

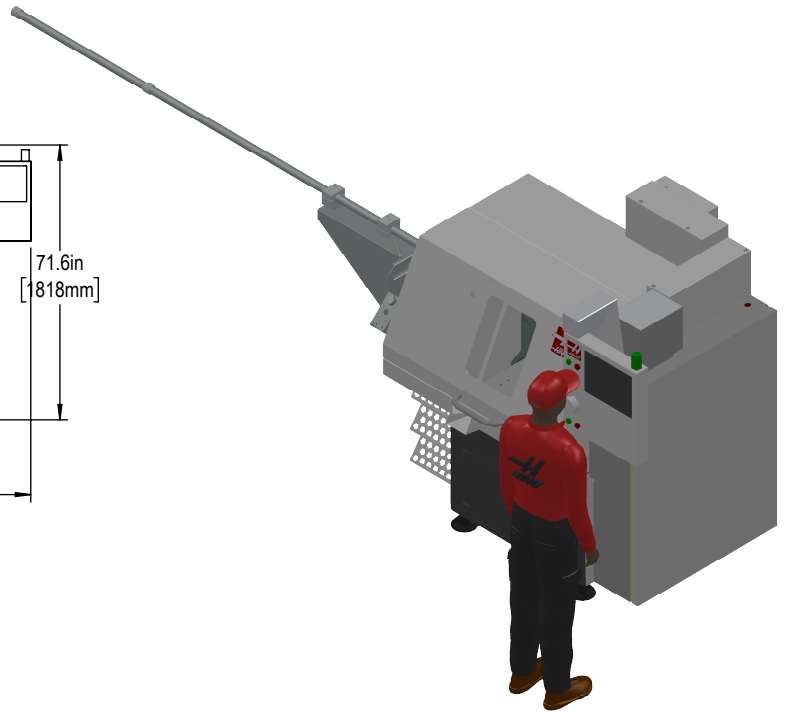

Leveling Pad Height

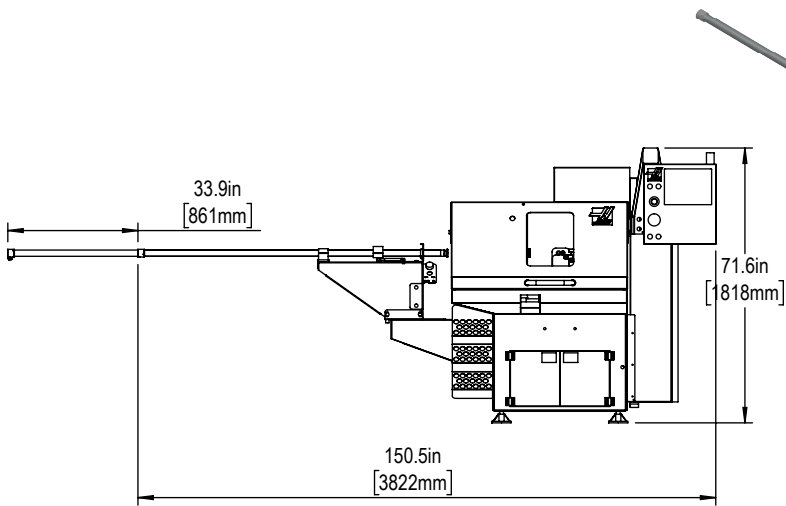
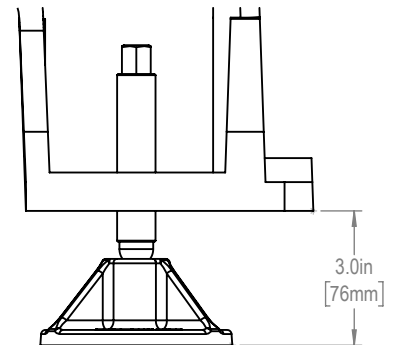

*All Height Dimensions Based on Suggested Leveling Pad Height

Shipping Dimensions

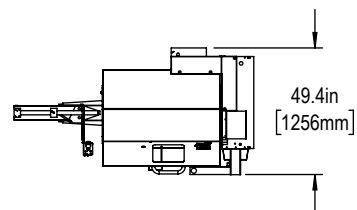
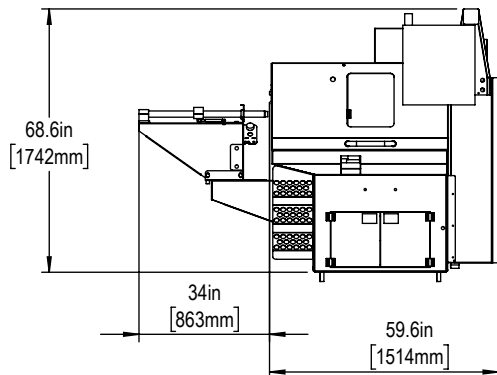

Air & Power

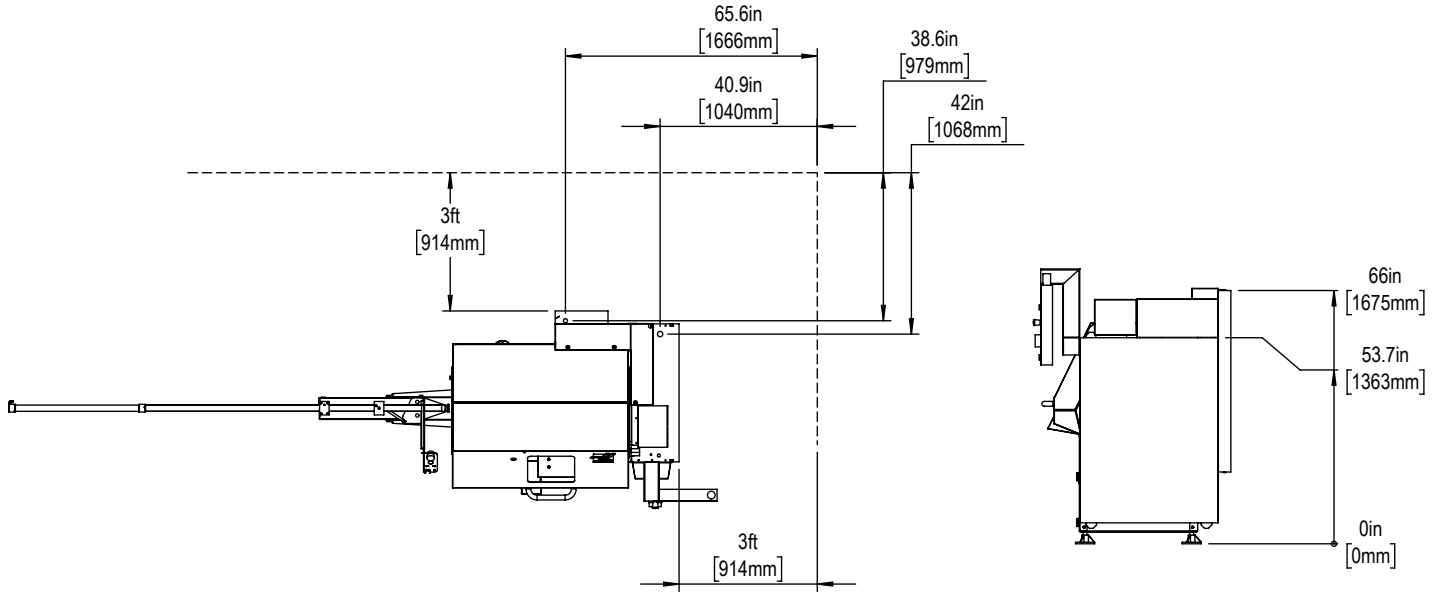

Maintain 3 feet [915mm] clearance to the nearest obstruction around all sides of machine perimeter for maintenance access

Note:
Machine must be placed on one continous concrete slab. Slab should extend 12in [305mm] beyond anchor holes in all directions

Anchor Pattern

Anchor Hole Detail
 Ø 1.0in[25mm]
 ▽ 2.0in[50mm]-
 ▽ 2.5in[66mm]

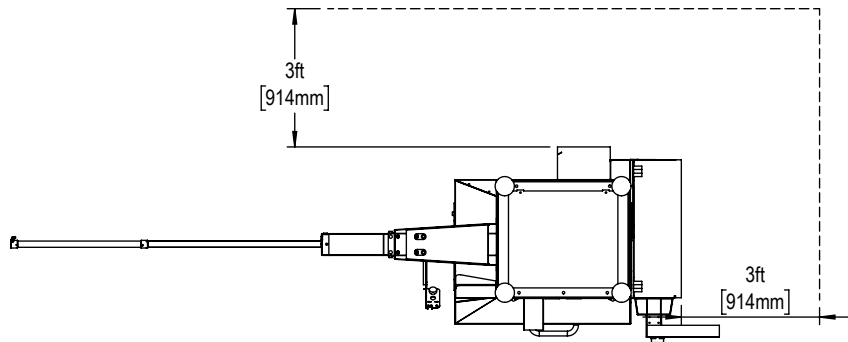

N/A



Height Breakdown

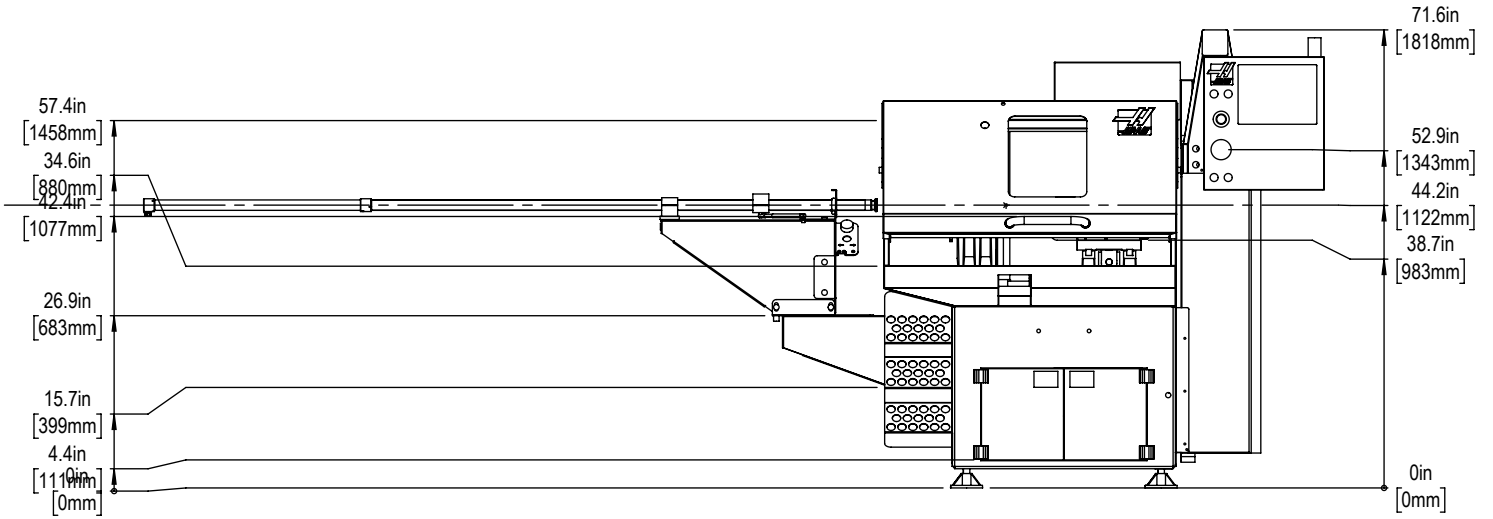

Width Breakdown

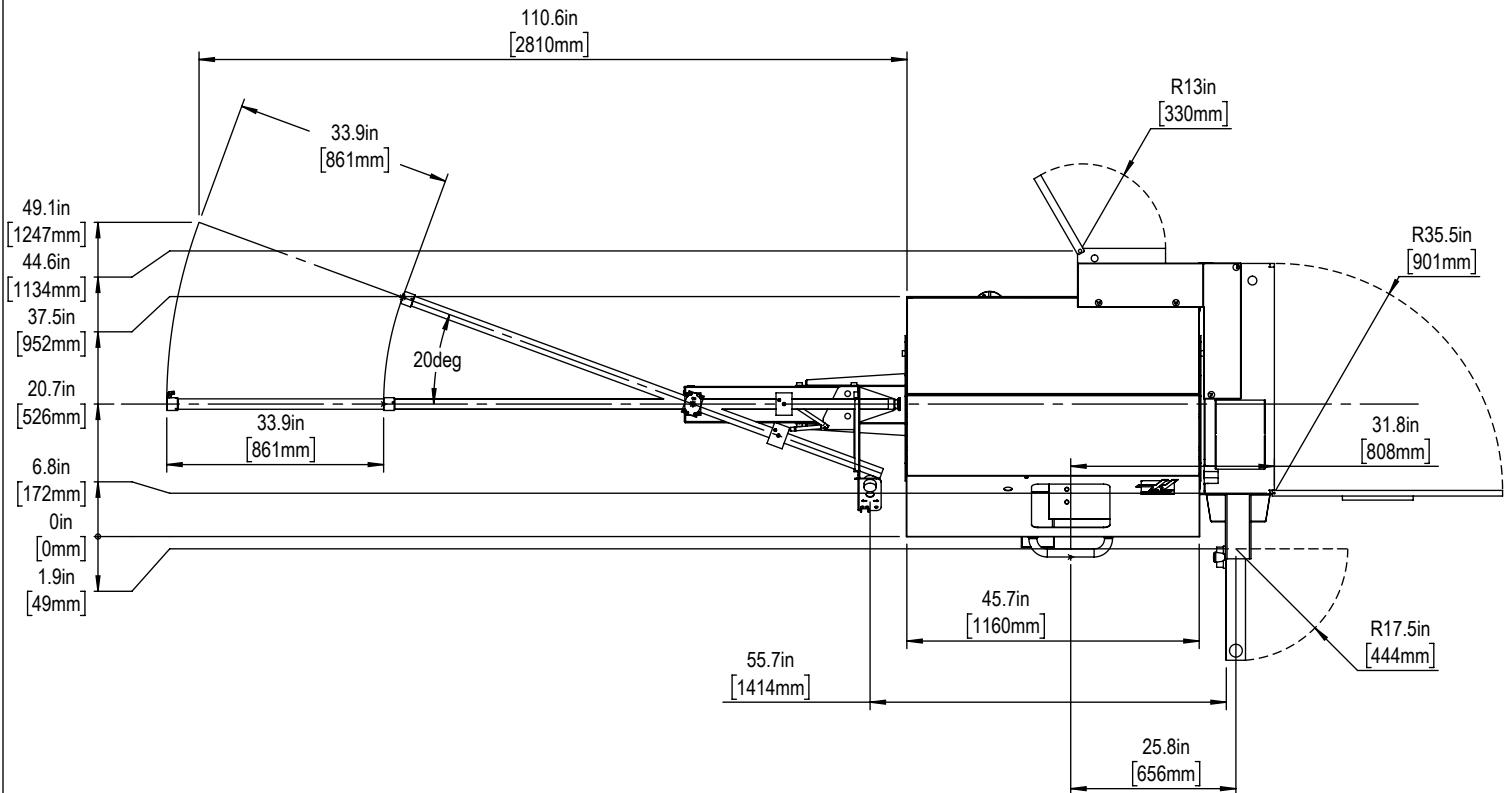

Parallel Plane Envelope Diagrams

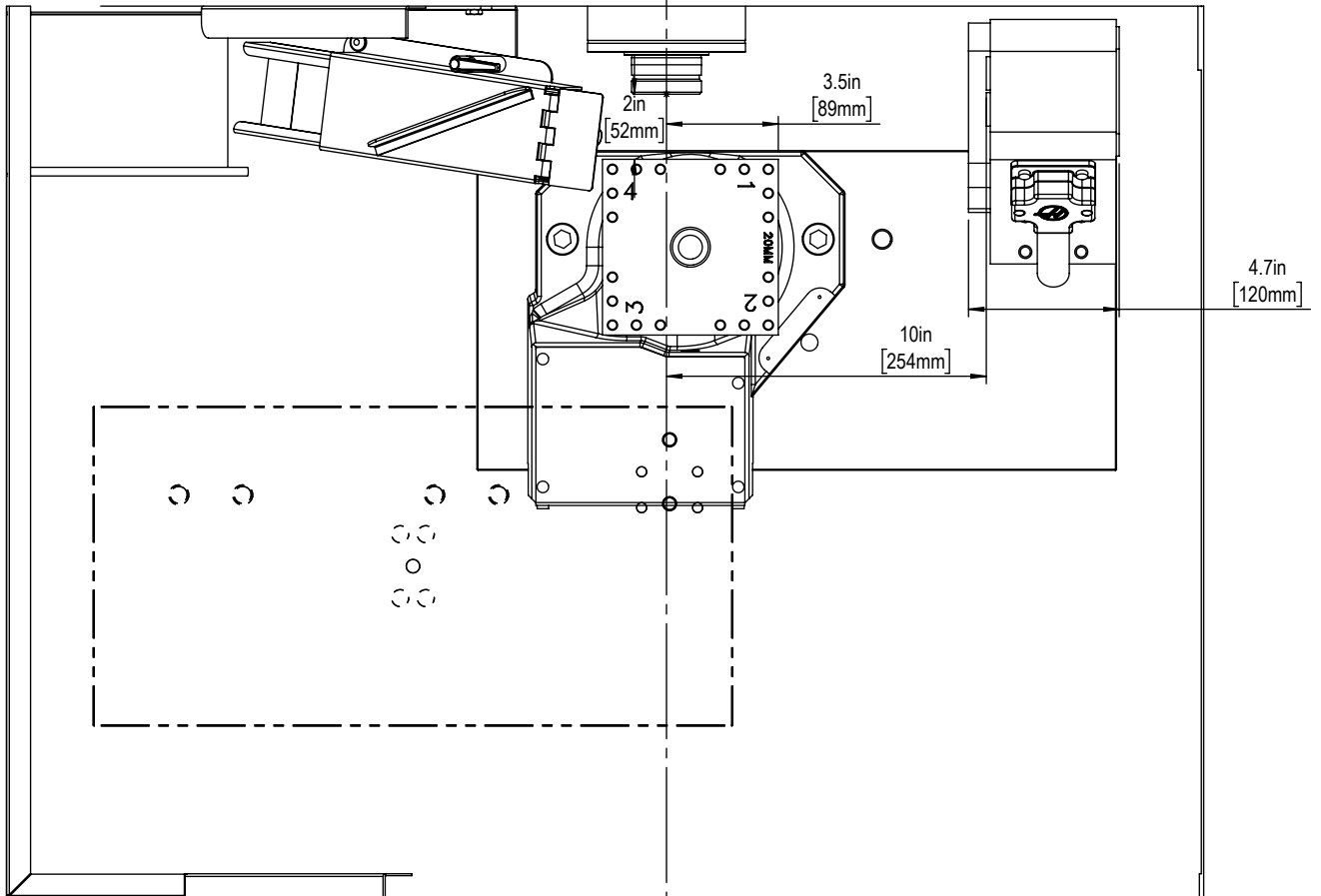
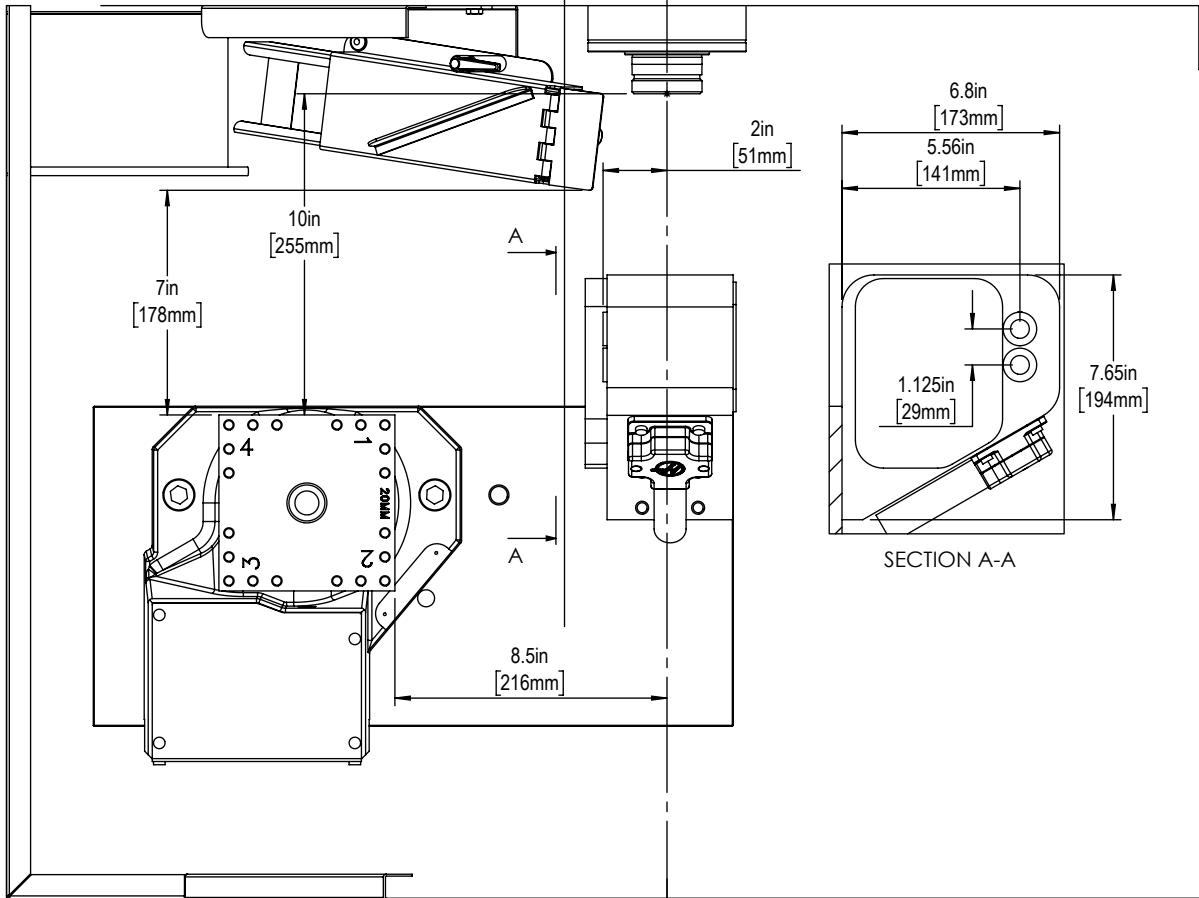

Parallel Plane Envelope Diagrams

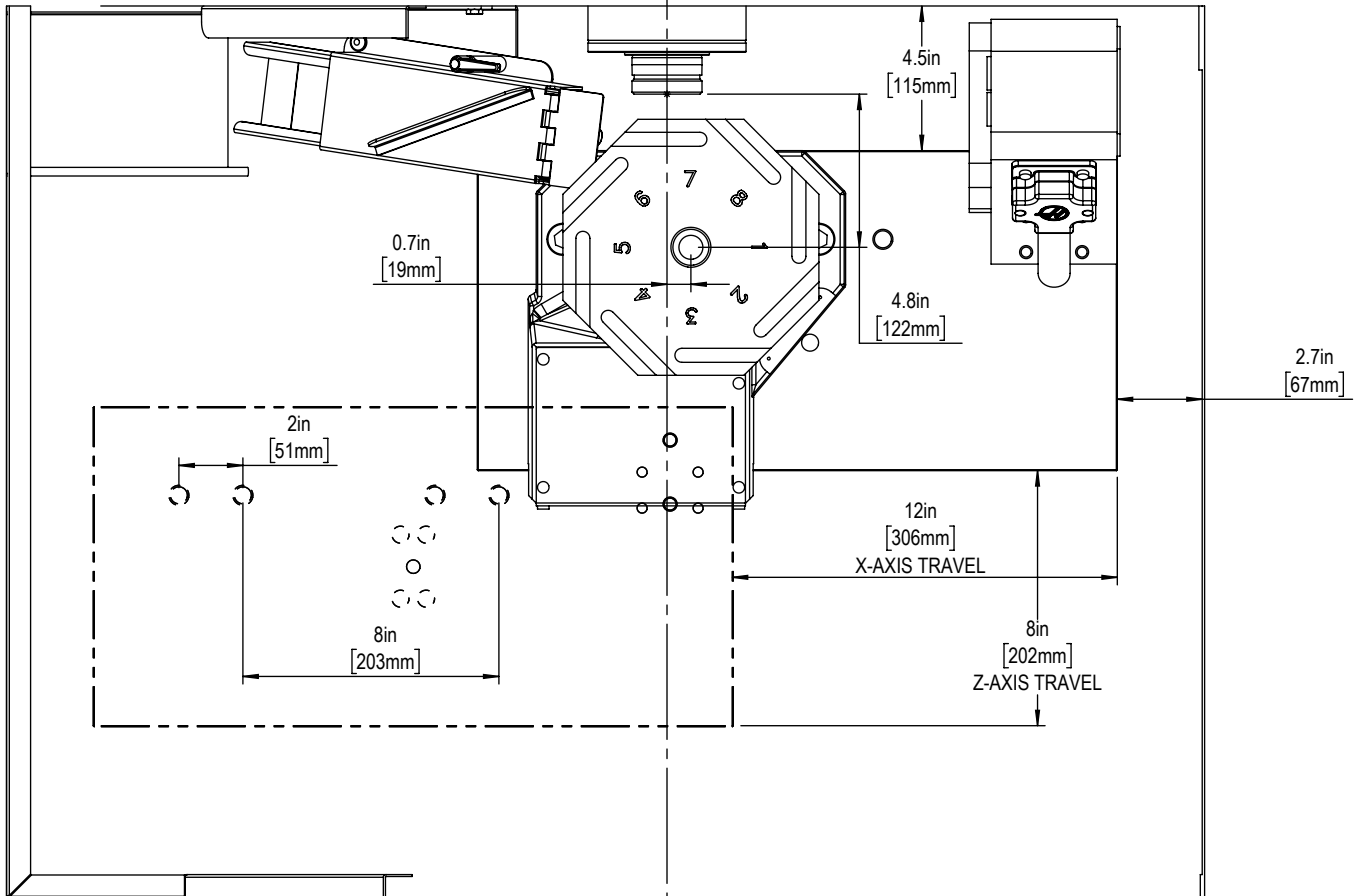
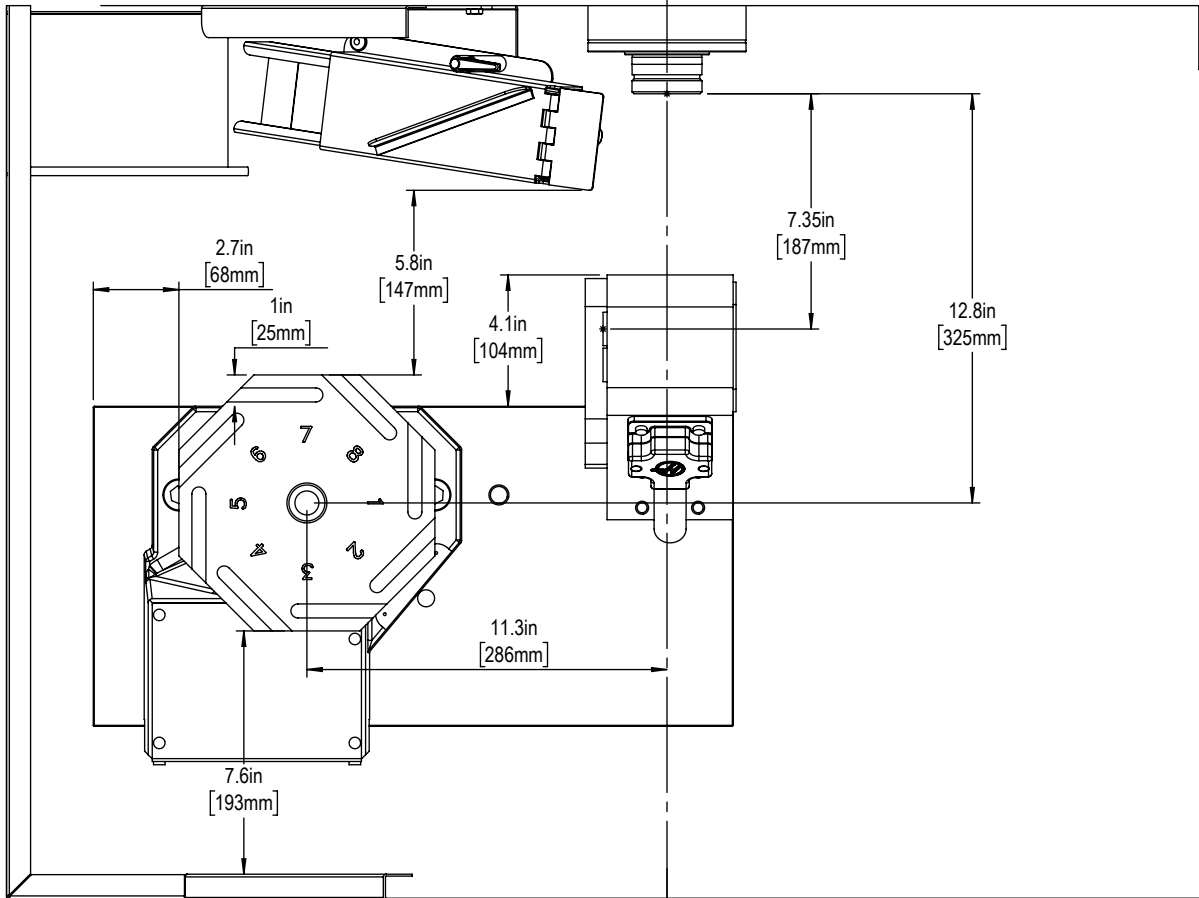

Parallel Plane Envelope Diagrams

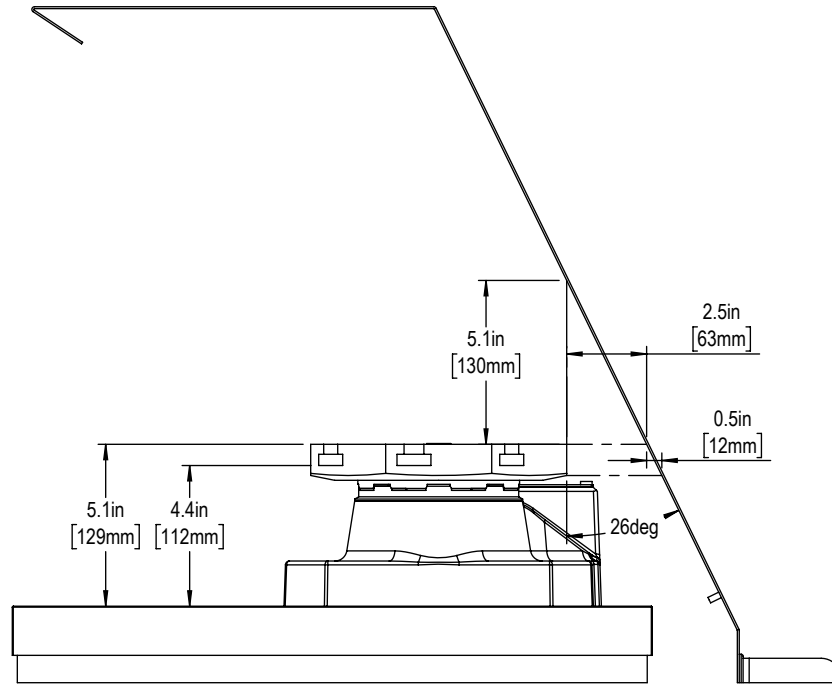

8-STATION TOOL TURRET

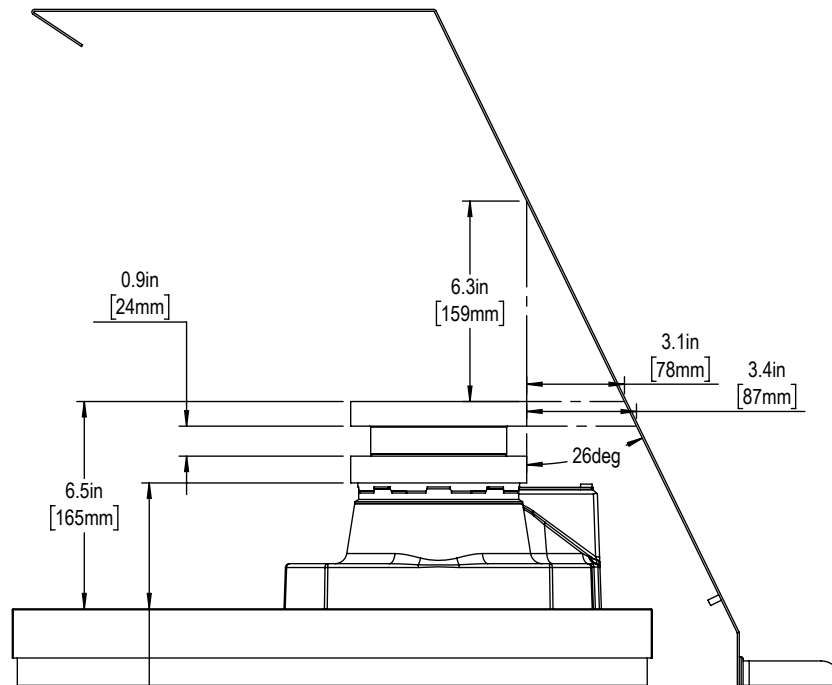

4-STATION TOOL TURRET

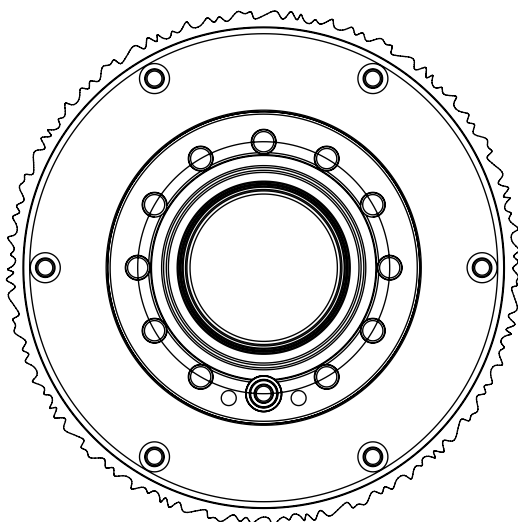
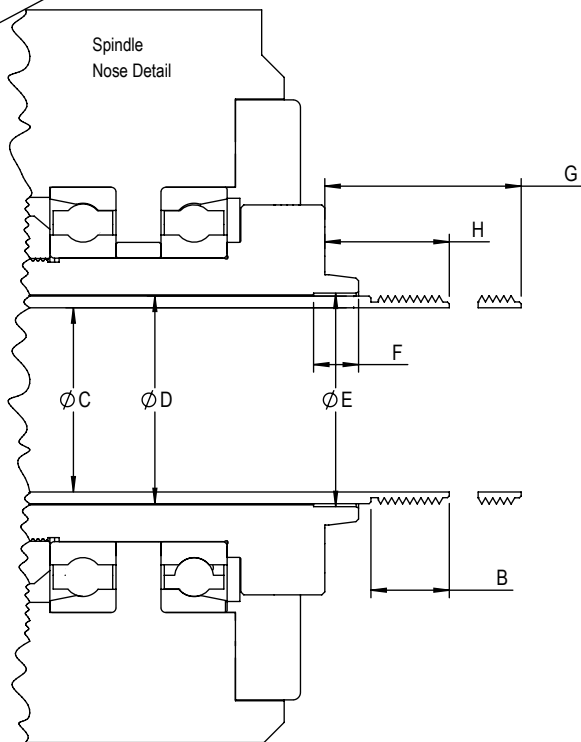
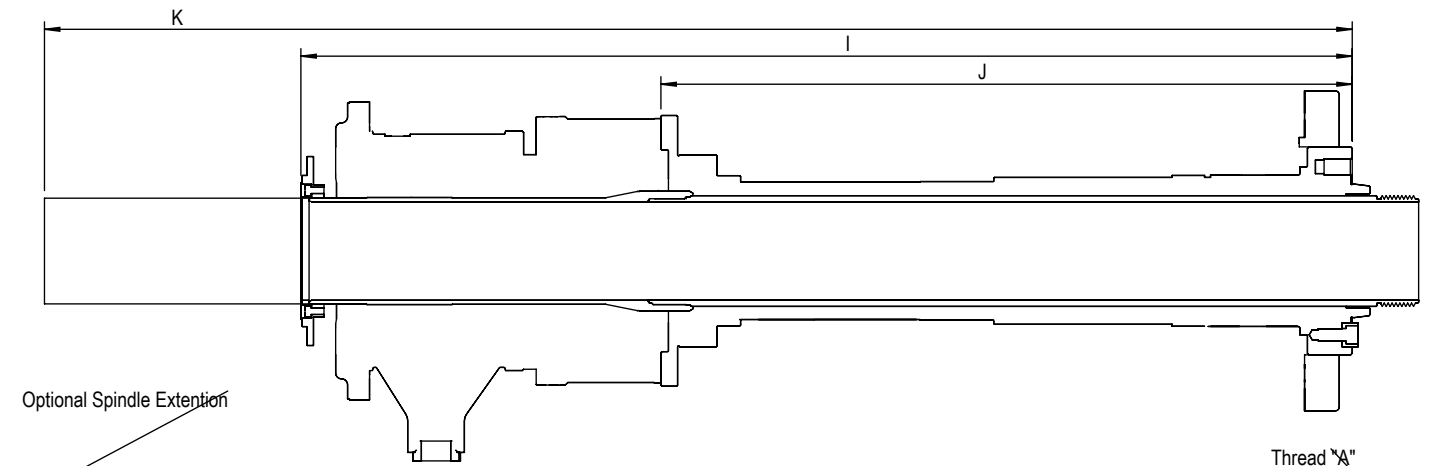

*Due to vendor variations discretion should be taken to verify validity of provided dimensions

Description	DIMENSION PARAMETER	CL-1	
		SAE (in)	METRIC (mm)
SPINDLE TYPE			
THREAD TYPE	A		
INTERNAL OR EXTERNAL			
LENGTH OF THREAD	B		
DRAWTUBE INTERNAL ϕ	C		
DRAWTUBE EXTERNAL ϕ	D		
COUNTERBORE INTERNAL ϕ	E		
COUNTERBORE DEPTH	F		
DRAWTUBE EXTENDED	G		
DRAWTUBE RETRACTED	H		
SPINDLE FACE TO BACK OF UNION	I		
SPINDLE FACE TO UNION ADAPTOR	J		
TO BACK OF EXTENSION (OPTION)	K		