

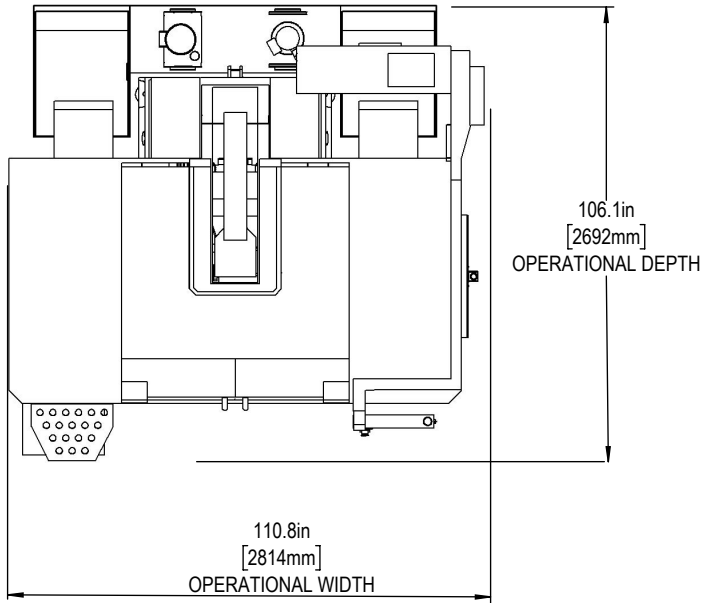

Installed Dimensions

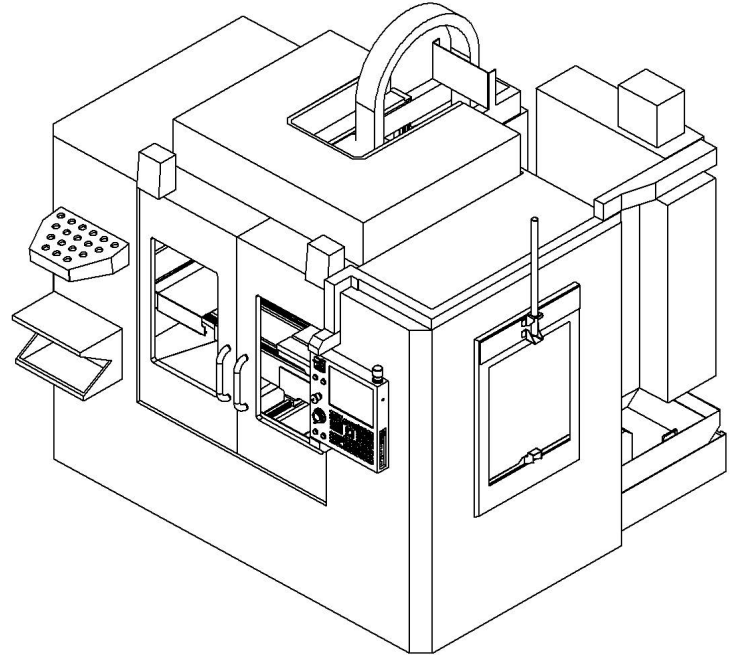

Leveling Pad Height

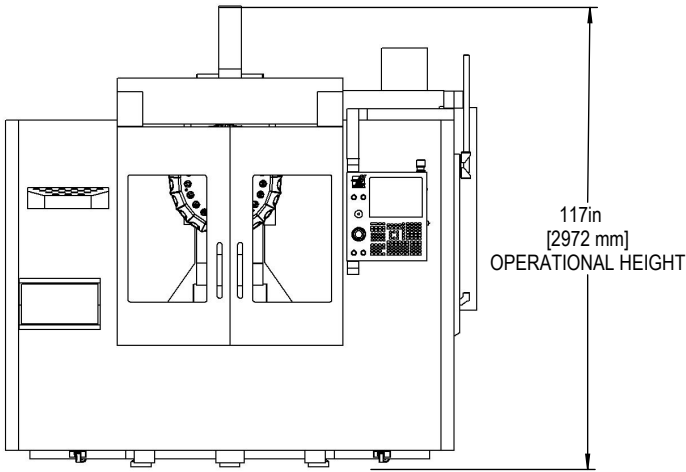
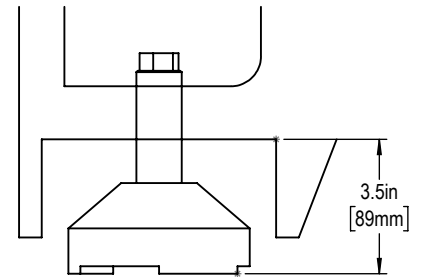

*All Height Dimensions Based on Suggested Leveling Pad Height

Shipping Dimensions

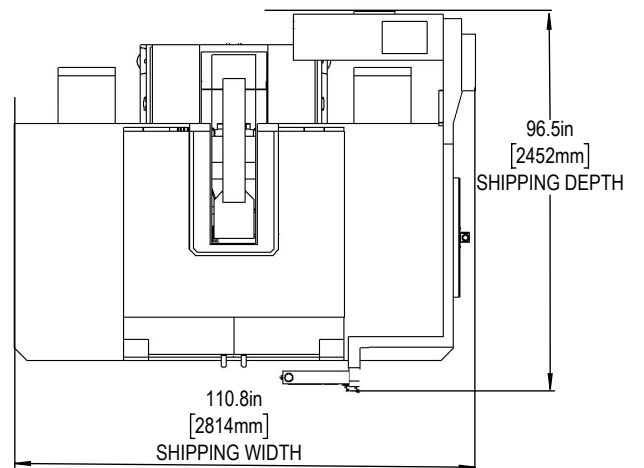
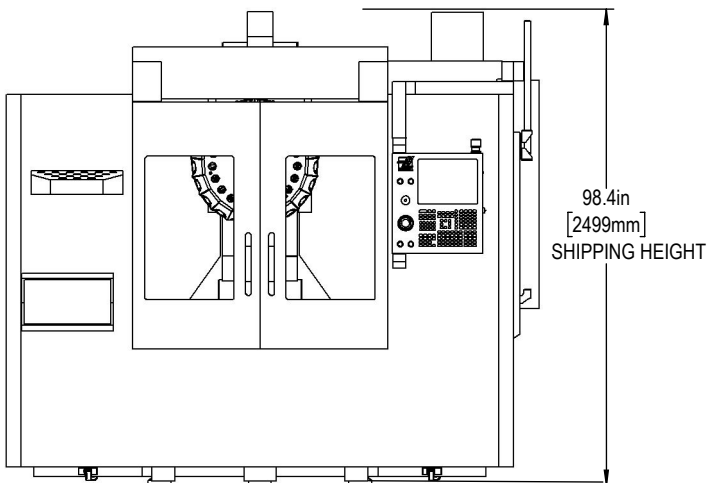

Air & Power

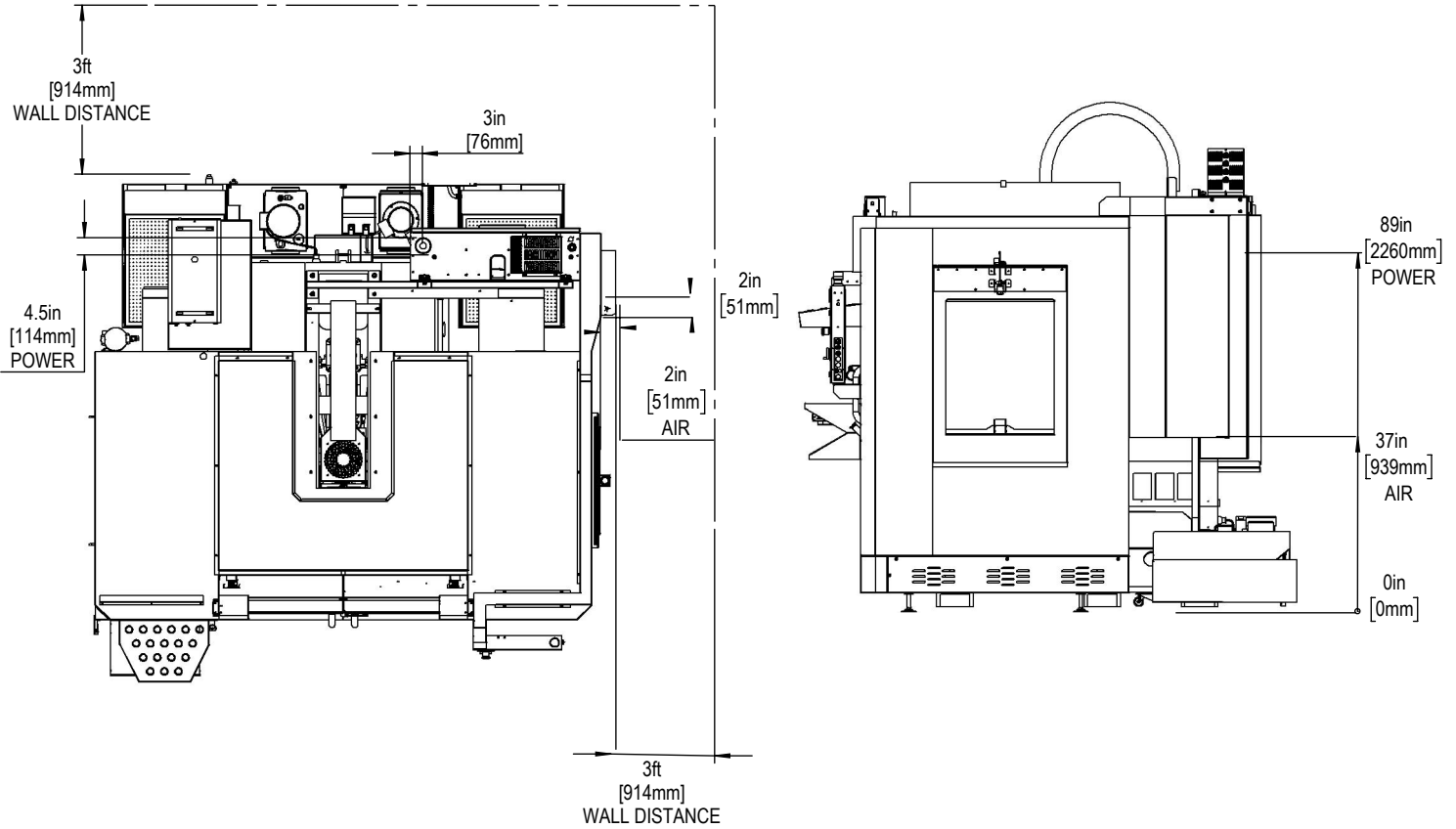

Maintain 3 feet [915mm] clearance to the nearest obstruction around all sides of machine perimeter for maintenance access

Note:
Machine must be placed on one continuous concrete slab. Slab should extend 12in [305mm] beyond anchor holes in all directions

Anchor Pattern

Anchor Hole Detail
 Ø 0.625in[25mm]
 ▽ 2.0in[50mm]-
 ▽ 2.25in[57mm]

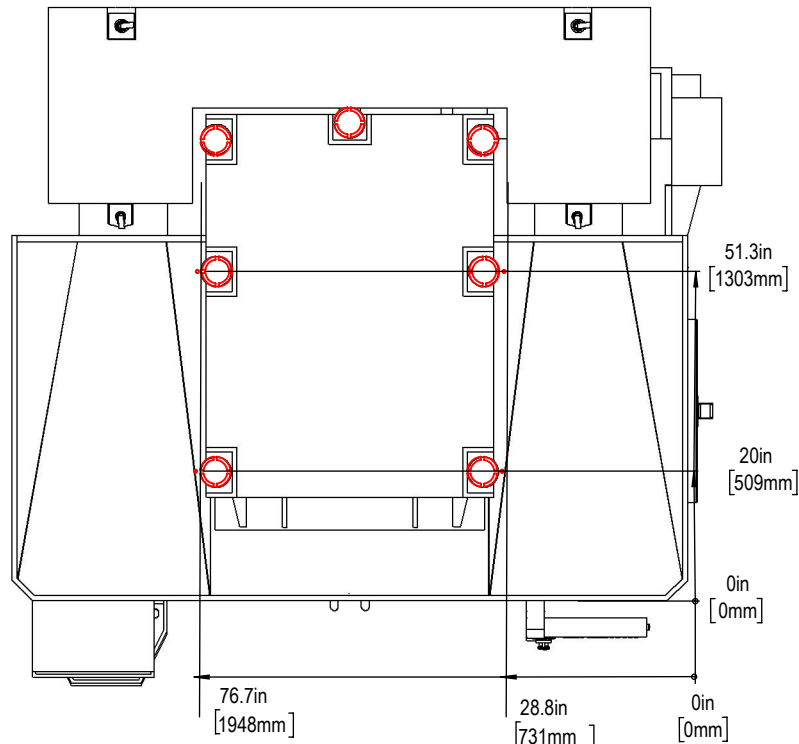

For precise locations and specifications please use template in Anchoring Kit found at Haascnc.com



Height Breakdown

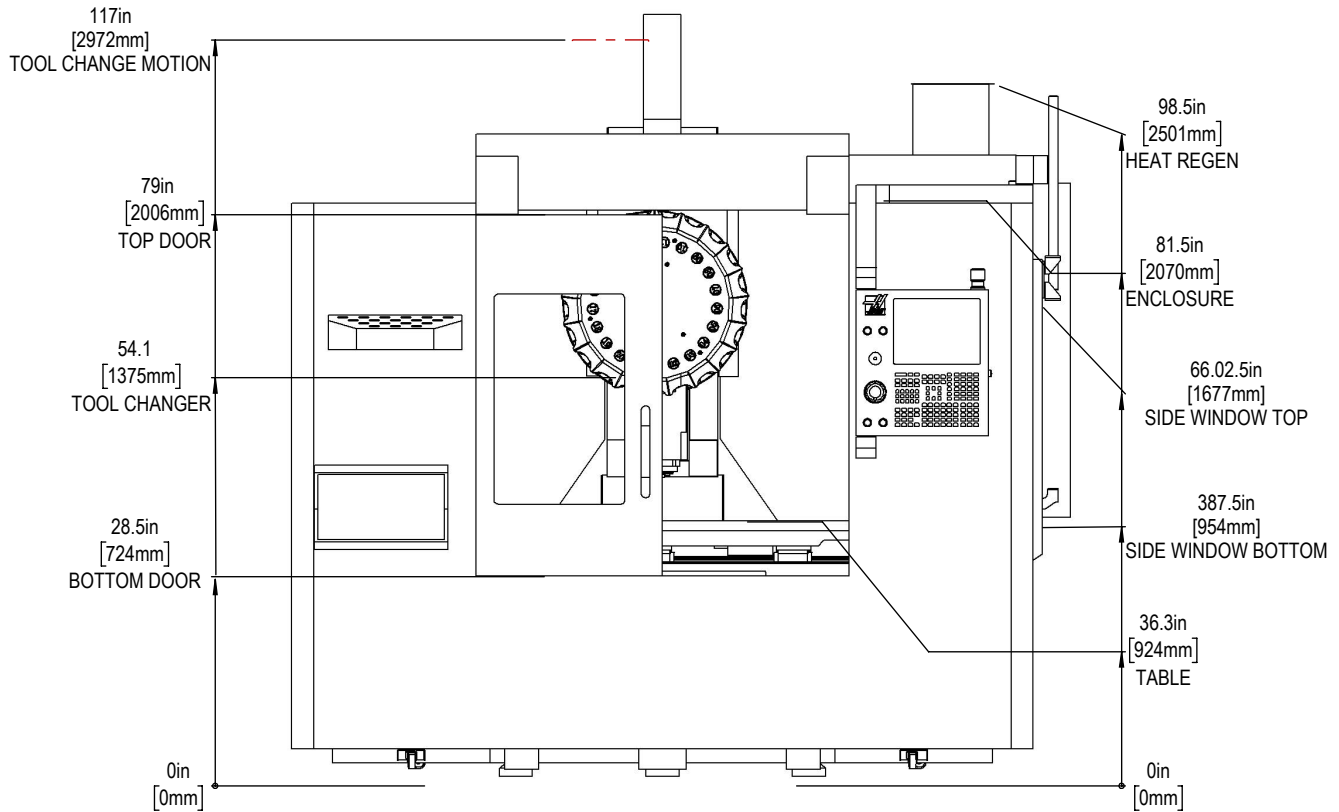

Width Breakdown

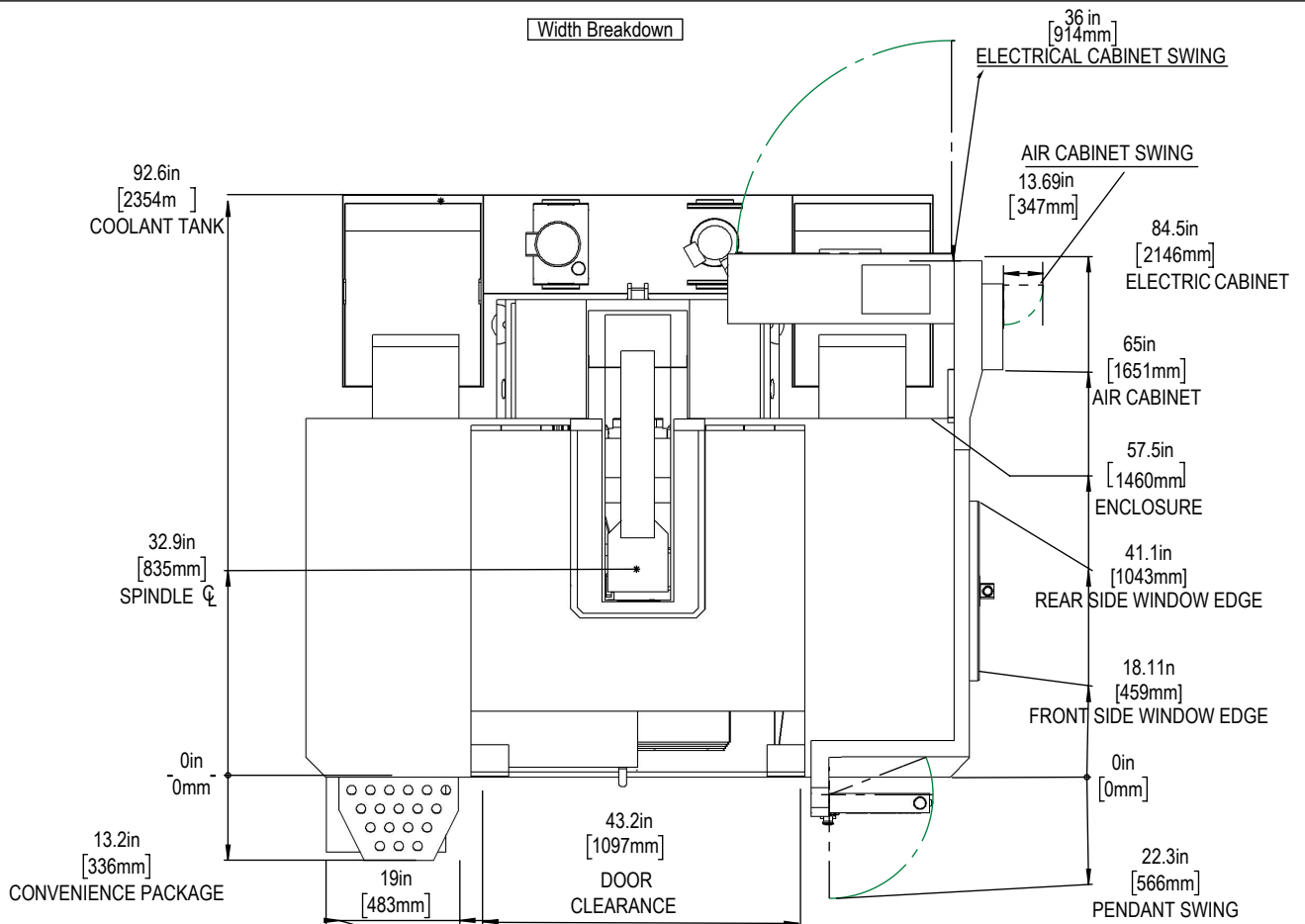

X&Y-Axis Travel and Clearance

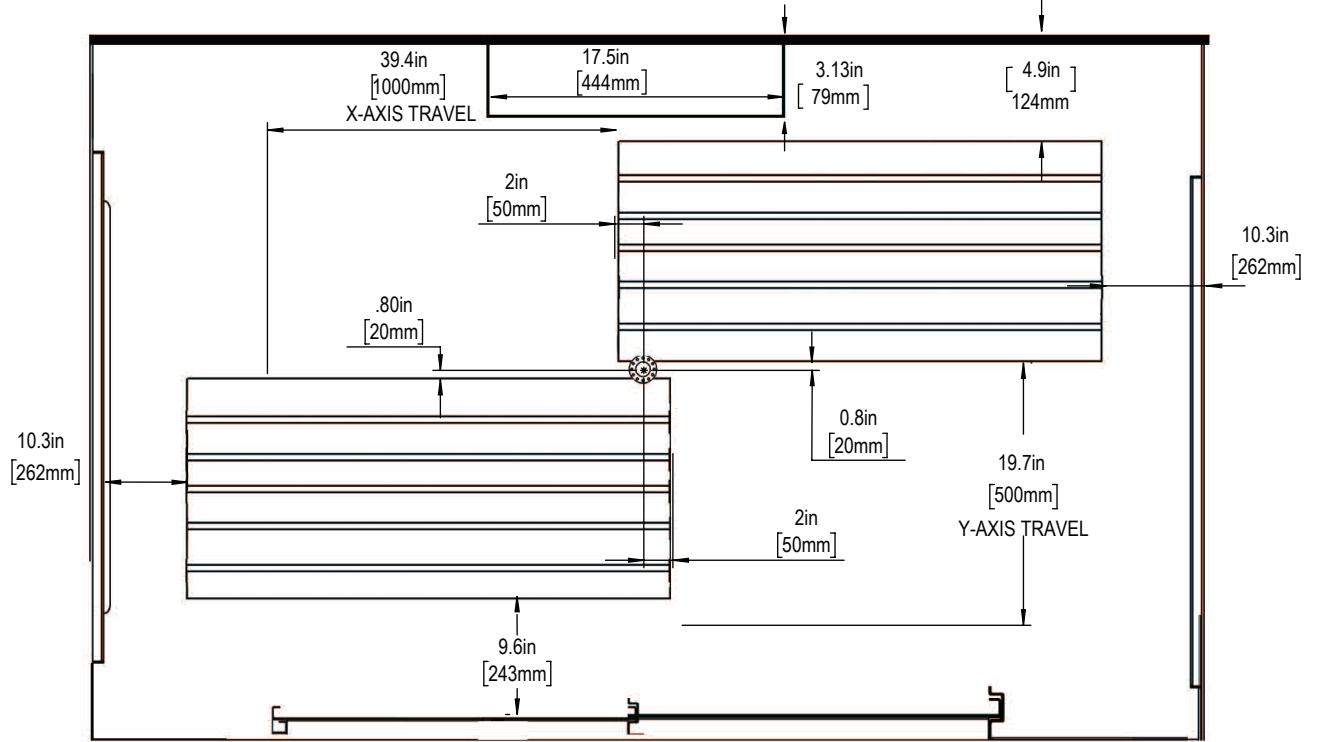

Z-AXIS TRAVEL & CLEARANCE

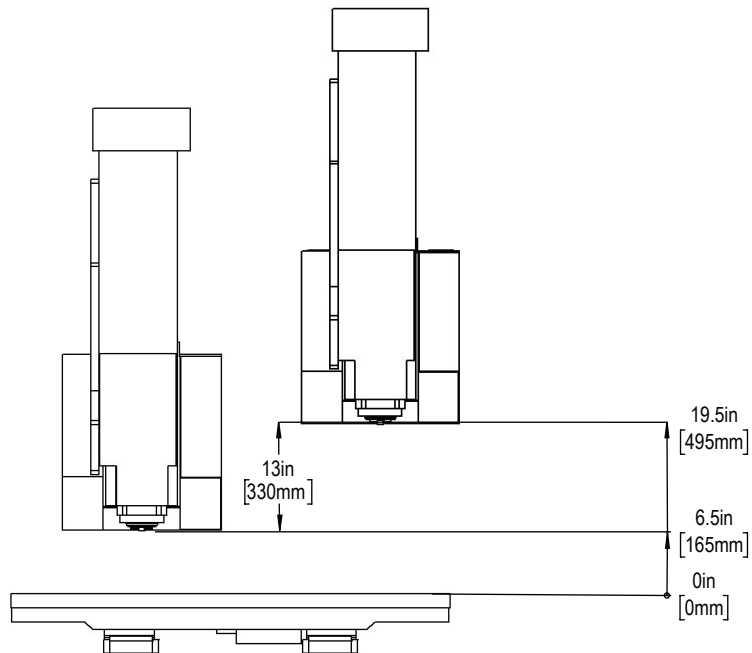

Table

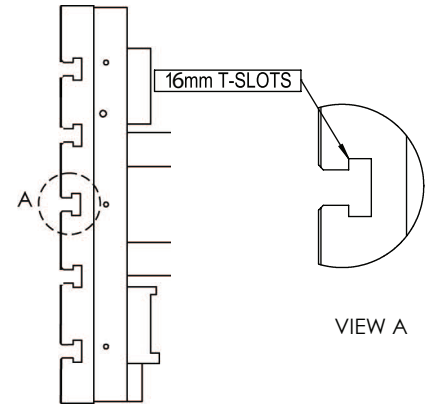
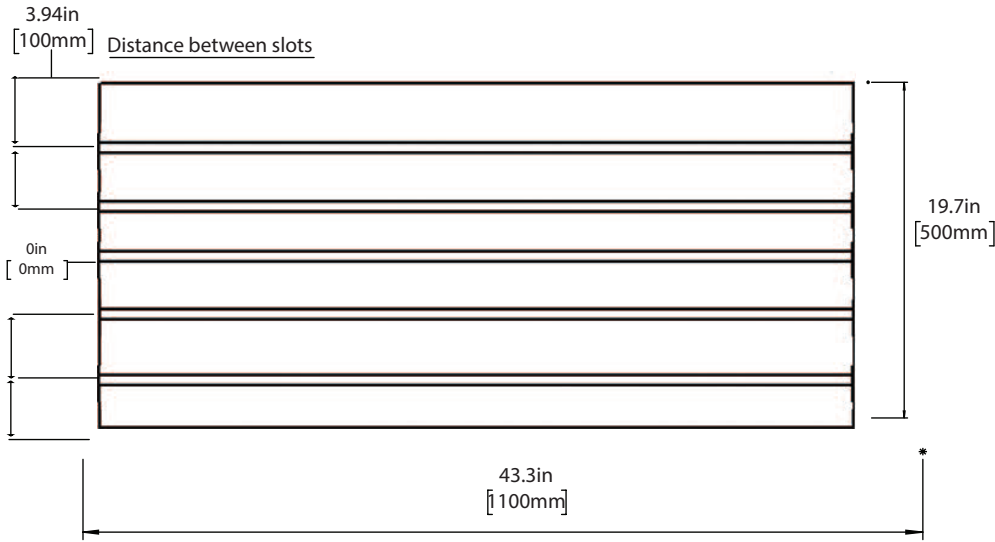

Slot Size	A	B	C	D	E	F
16mm	0.628±0.002	1.06±0.02	0.640±0.010	0.420±0.010	0.06x45°	0.020x45°

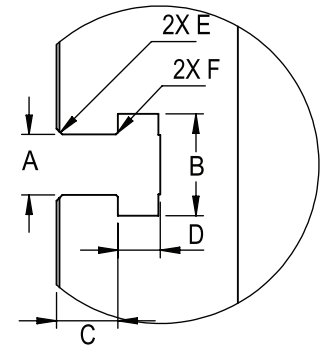

T-Slot Dimensions in inches

Tool Changer

TOOL CHANGE HEIGHT

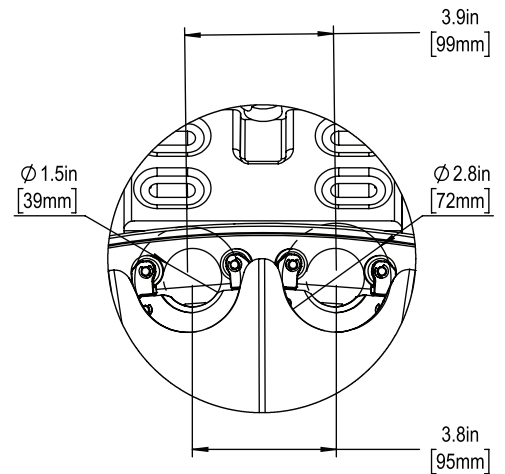
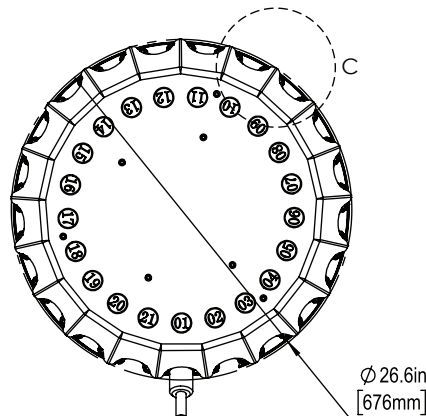
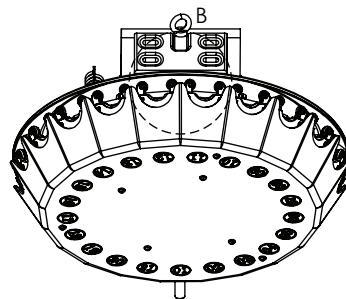
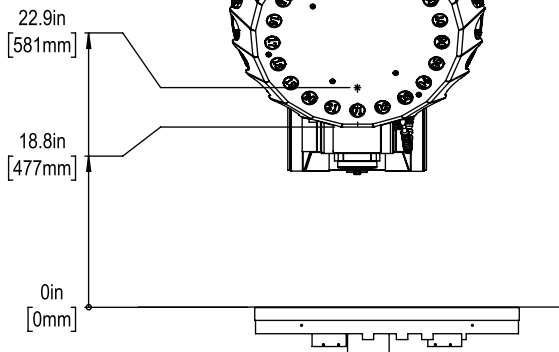

VIEW B

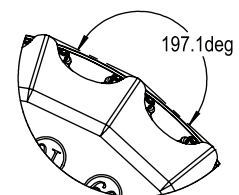

VIEW C