

2024/ 08

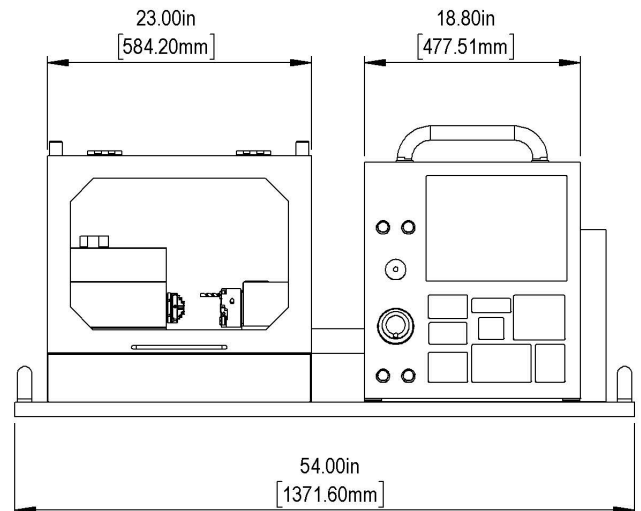
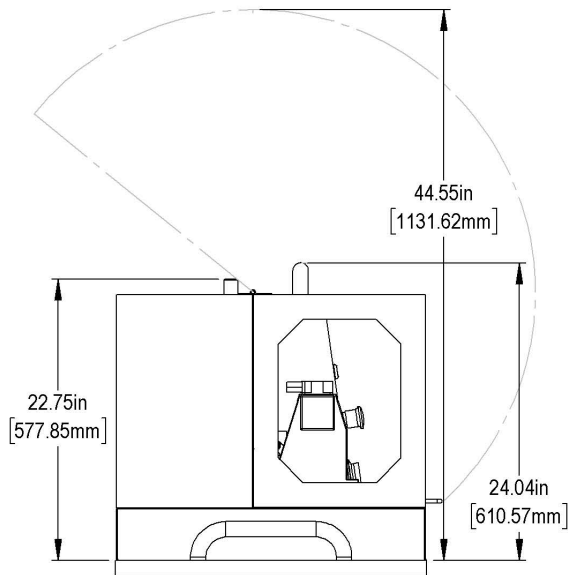
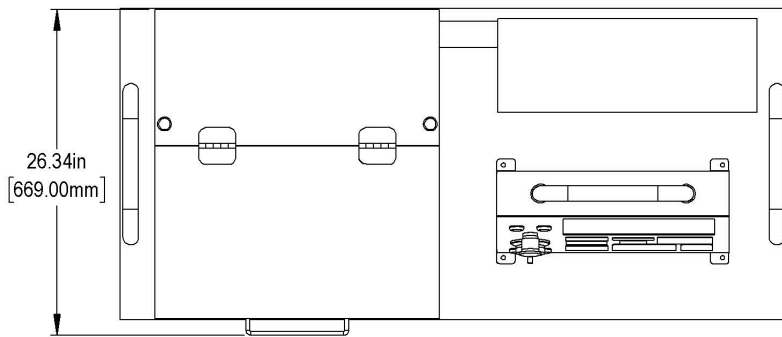
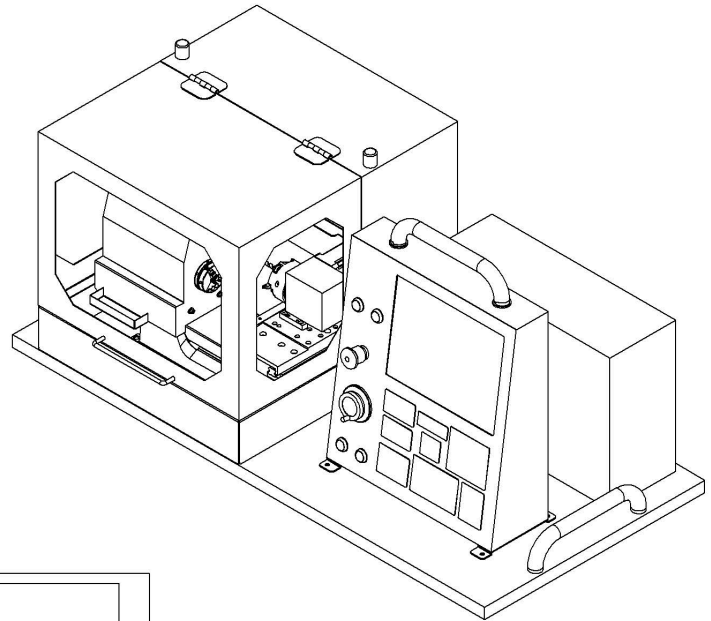
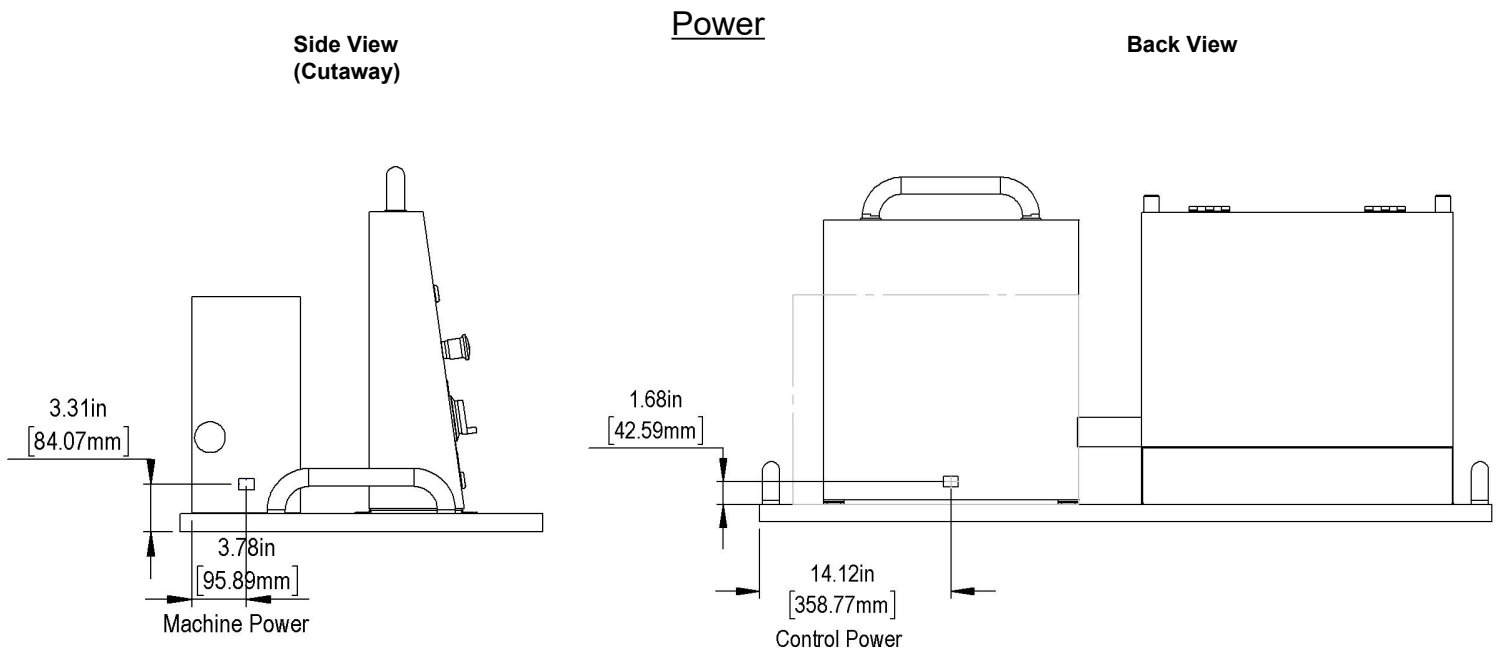

All dimensions based on stackup of sheetmetal, subject to variation of 1/2" (13 mm)

*Due to continual product improvements, machine dimensions are subject to change without notice.

**Note**

1. No air connection. Desktop Lathe does not require compressed air or coolant
2. (2x) Power cords with C13 connection are included with the machine and plug into a standard wall outlet. No dedicated power drop is required.

Anchor Pattern

Anchoring is recommended if Desktop Lathe is installed on any type of portable tool box, table or cart, and may be anchored in stationary installations if desired

Anchor screw type will depend on the table material. Recommended anchors include wood screws, machined nuts and bolts, or any metal anchor appropriate for the surface the Desktop Lathe sits on

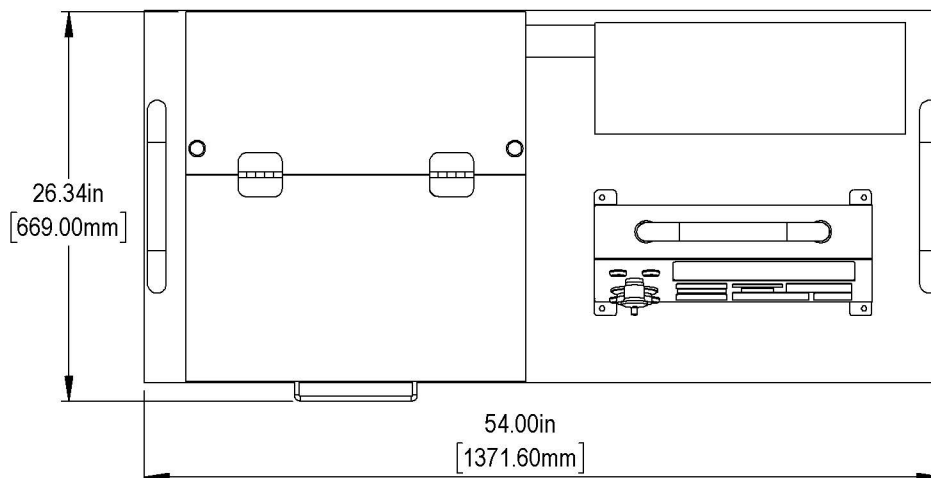

All dimensions based on stackup of sheetmetal, subject to variation of 1/2" (13 mm)

Installation tip - The Desktop Lathe fits well on a rolling tool box that is a minimum 46" [1170mm] wide x 24" [610mm] deep. Boxes this size are available at many hardware stores

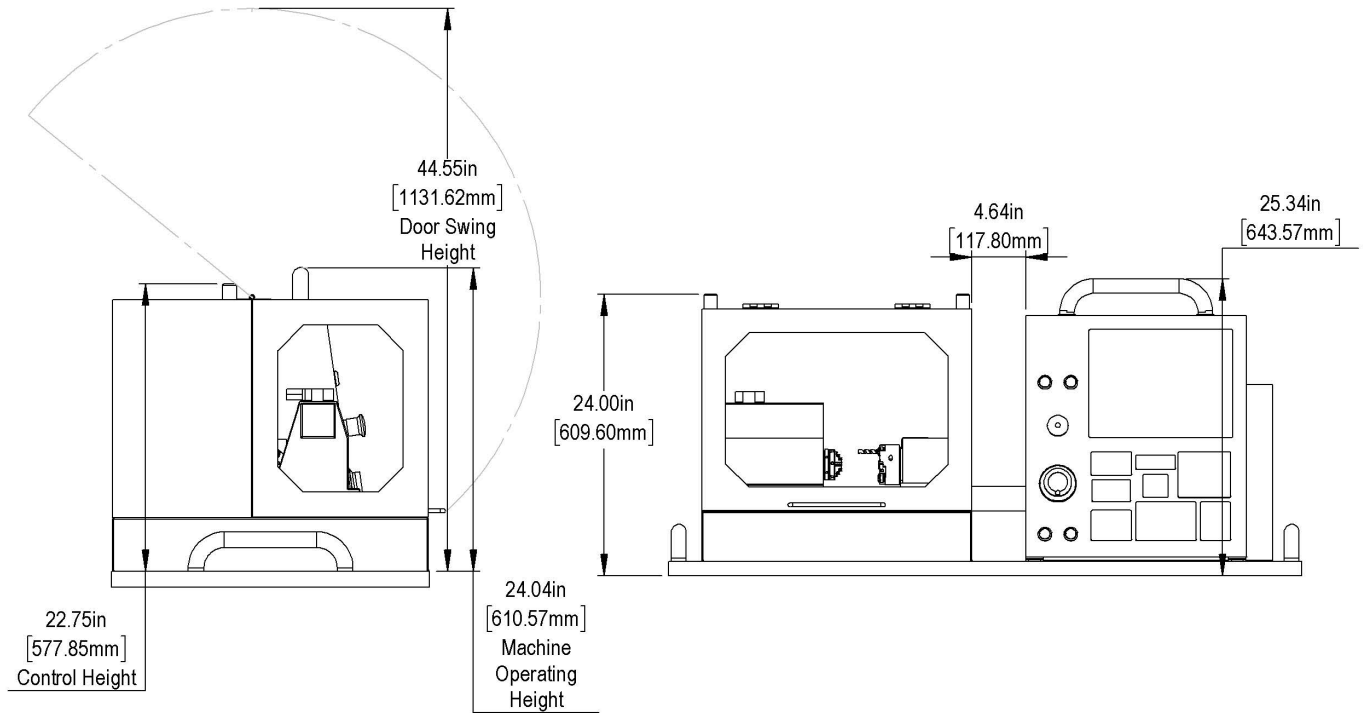
Height Breakdown

All dimensions based on stackup of sheetmetal, subject to variation of 1/2" (13 mm)

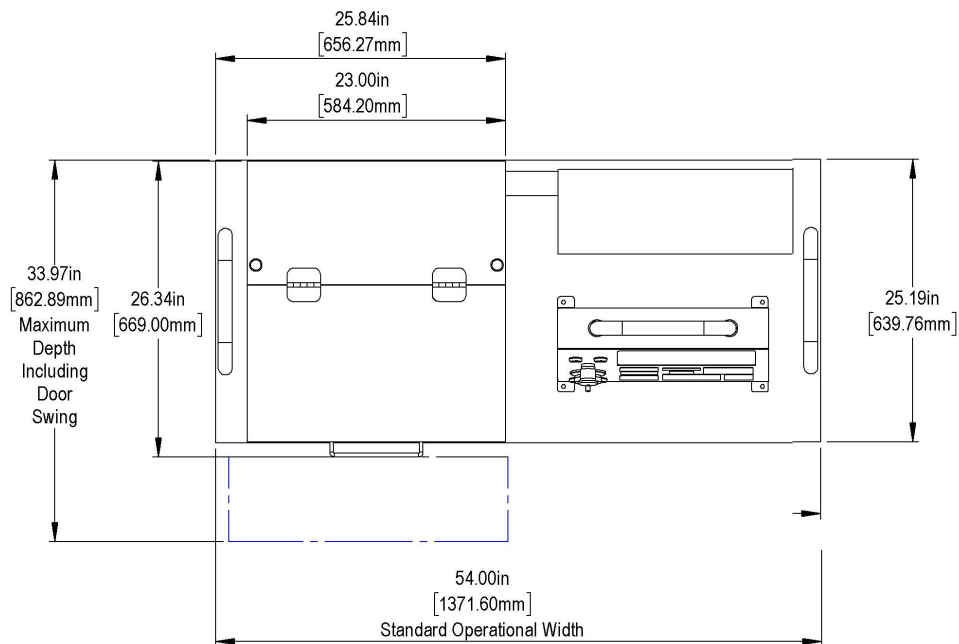
Width & Depth Breakdown

All dimensions based on stackup of sheetmetal, subject to variation of 1/2" (13 mm)

*Due to continual product improvements, machine dimensions are subject to change without notice.

X& Z-Axis Clearance

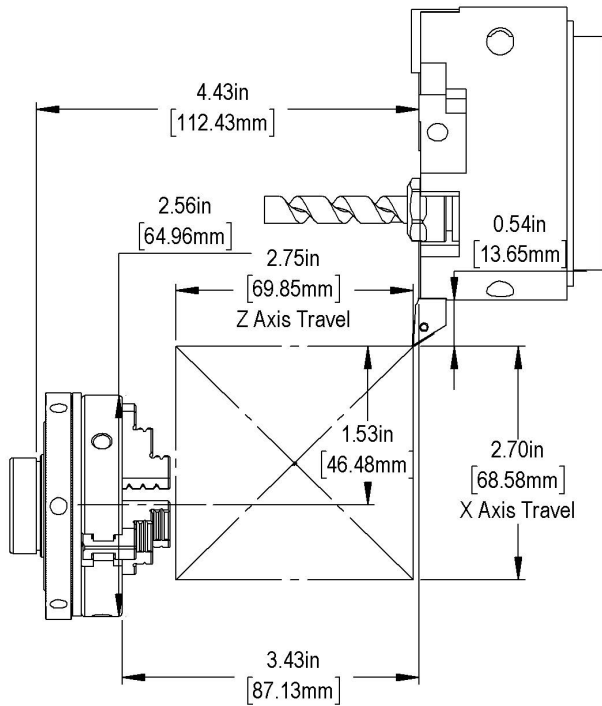

Turning Stick Dimensions

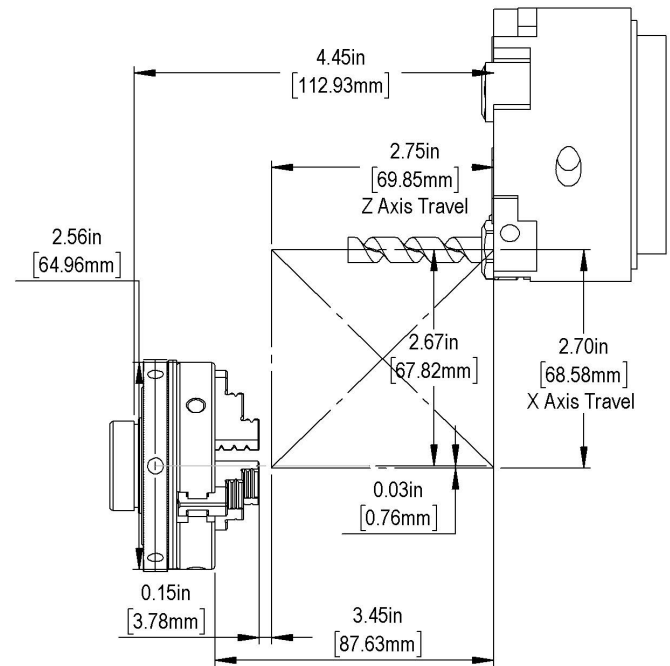

ID Holder Dimensions

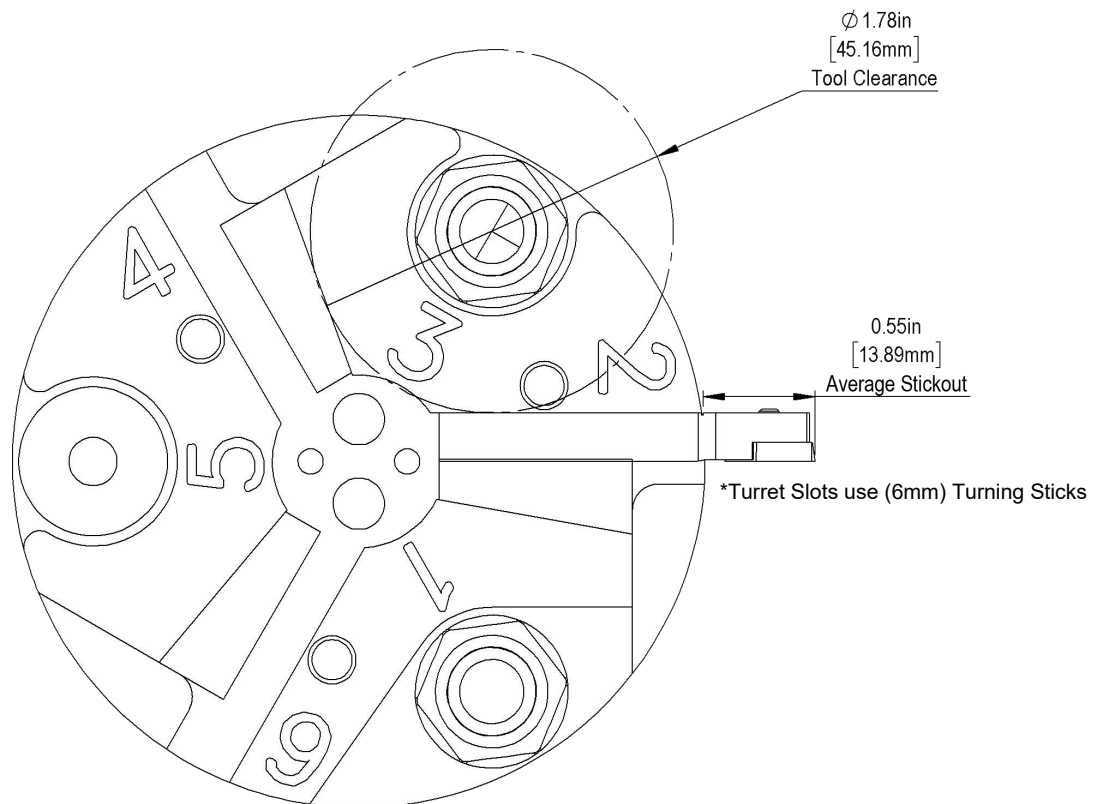

*Due to continual product improvements, machine dimensions are subject to change without notice.