

INSTALLED DIMENSIONS

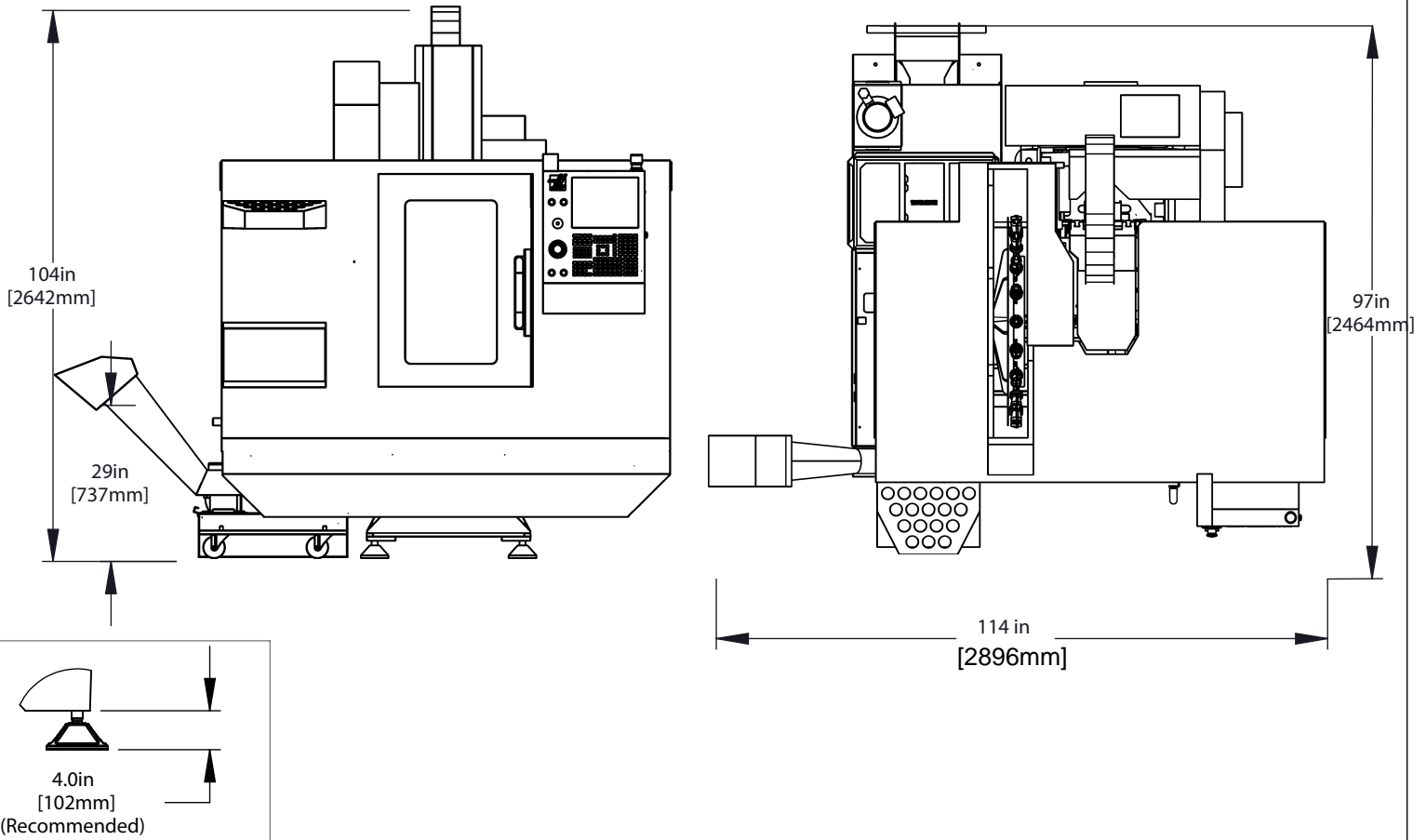

SHIPPING DIMENSIONS

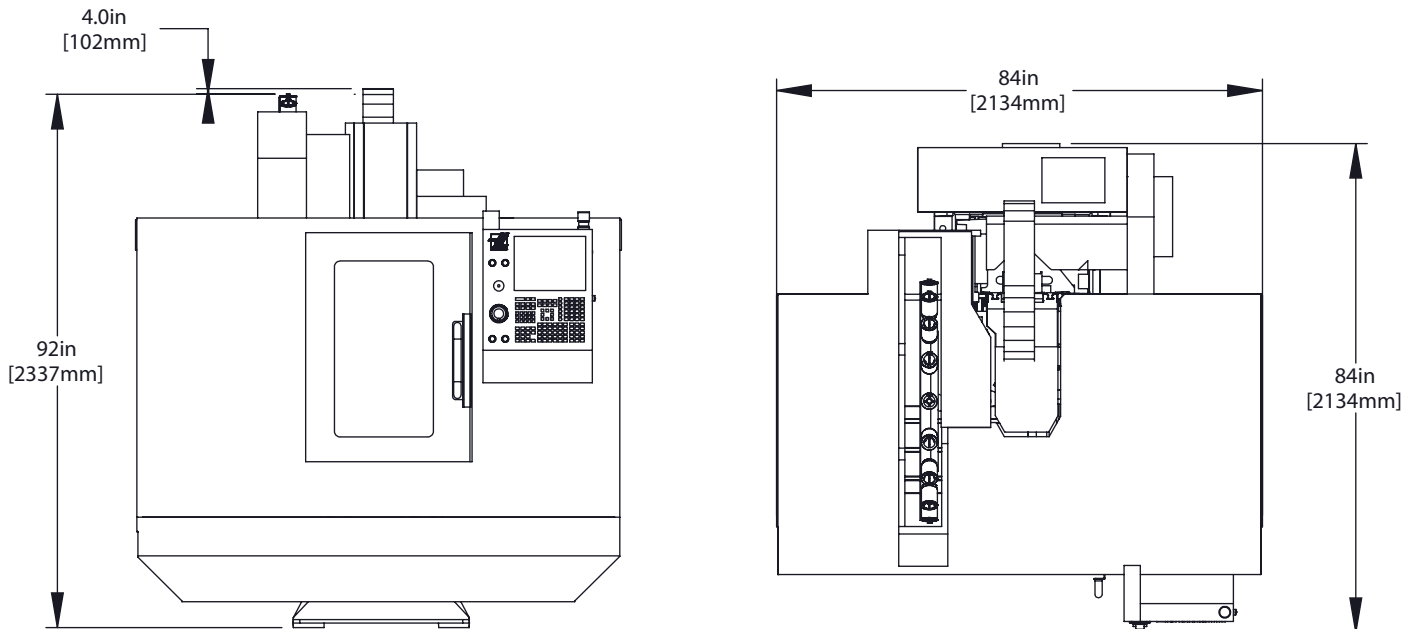

All dimensions based on stackup of sheetmetal, subject to variation of 1/2" (13 mm)

OPERATIONAL HEIGHT

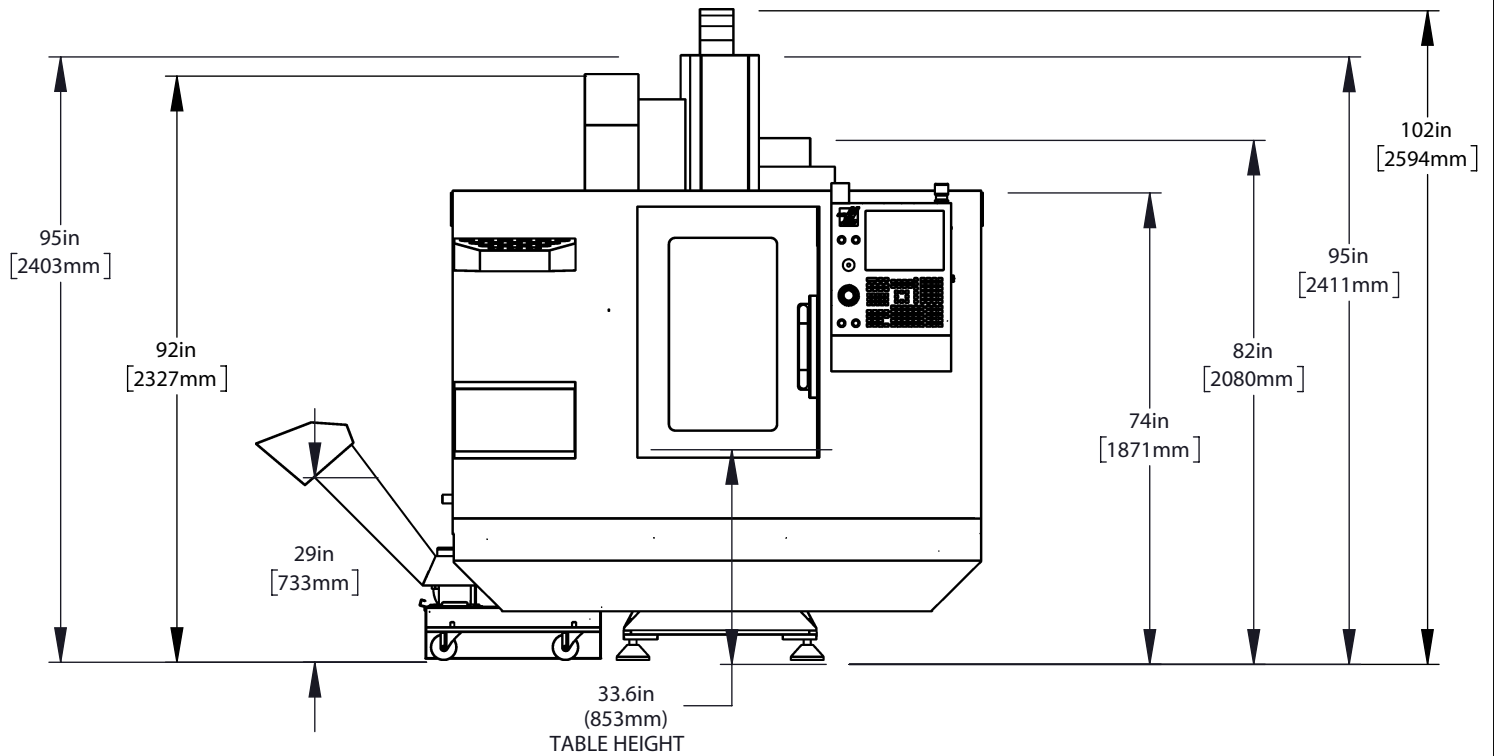

All dimensions based on stackup of sheetmetal, subject to variation of 1/2" (13 mm)

OPERATIONAL WIDTH AND DEPTH

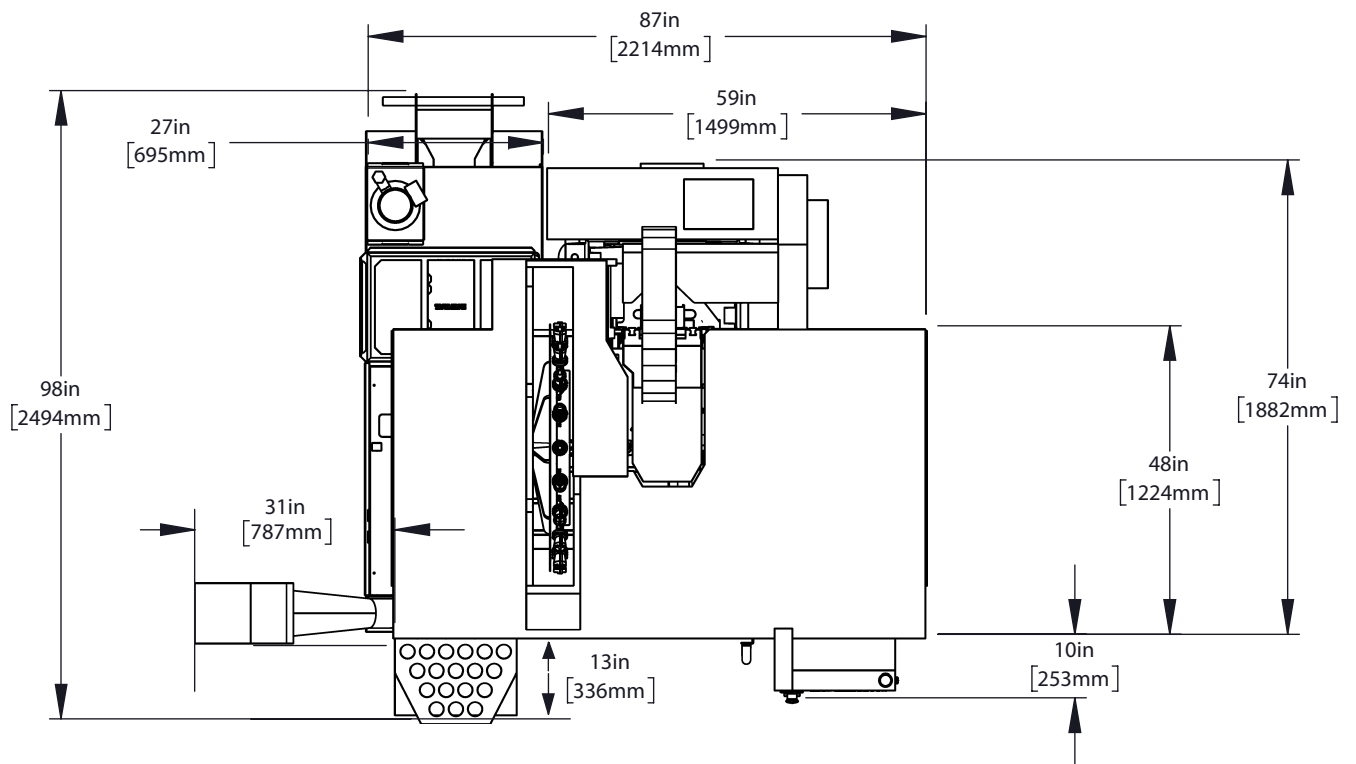

All dimensions based on stackup of sheetmetal, subject to variation of 1/2" (13 mm)

FRONT LOADING AUTO-DOOR

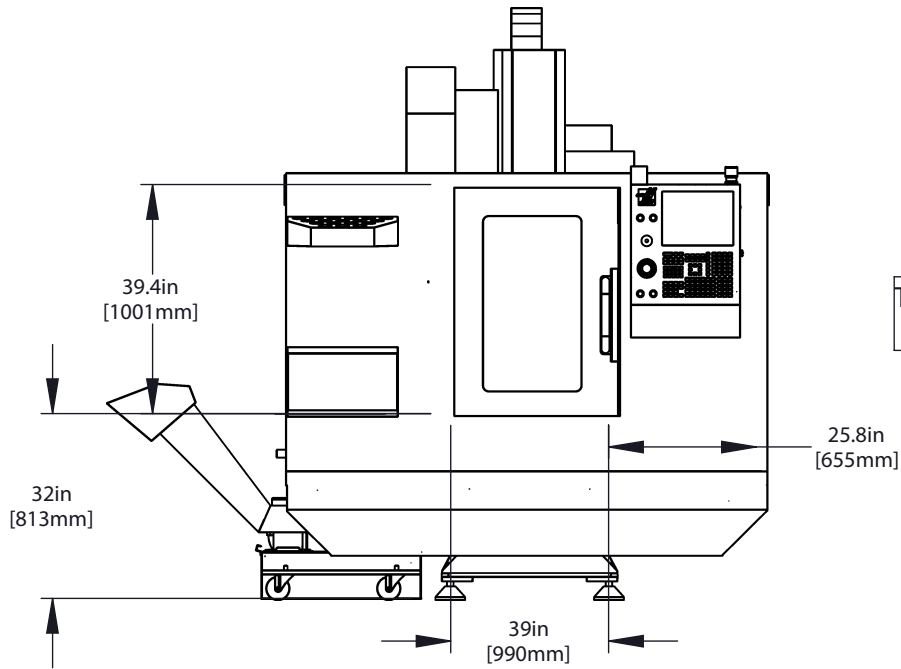
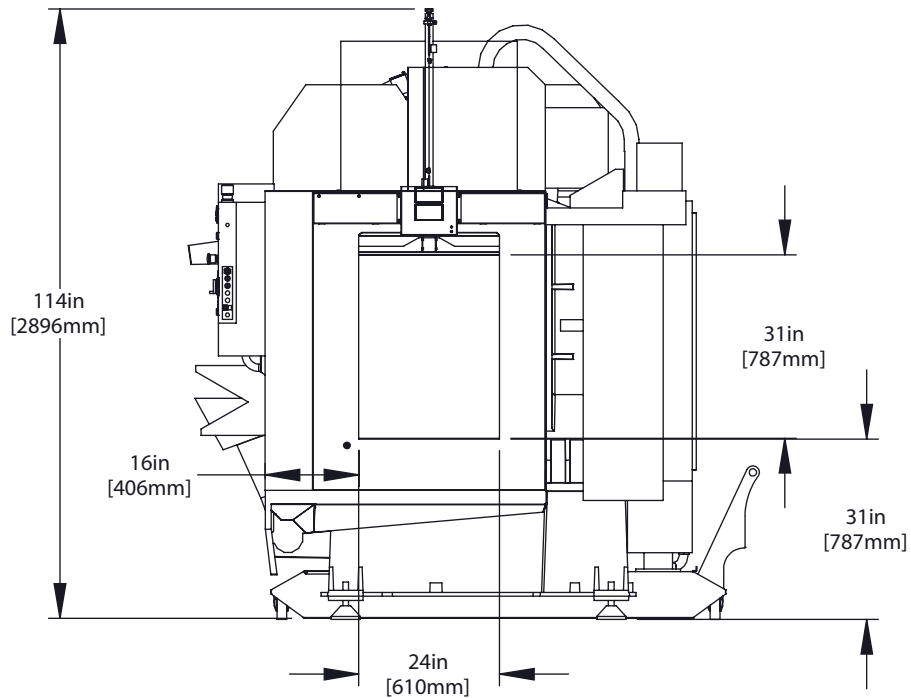

TABLE HEIGHT IS
33.6in (853mm)

All dimensions based on stackup of sheetmetal, subject to variation of 1/2" (13 mm)

SIDE LOADING AUTO-WINDOW



HEIGHTS MAY VARY
BASED ON
INSTALLATION HEIGHT

All dimensions based on stackup of sheetmetal, subject to variation of 1/2" (13 mm)

AIR & POWER

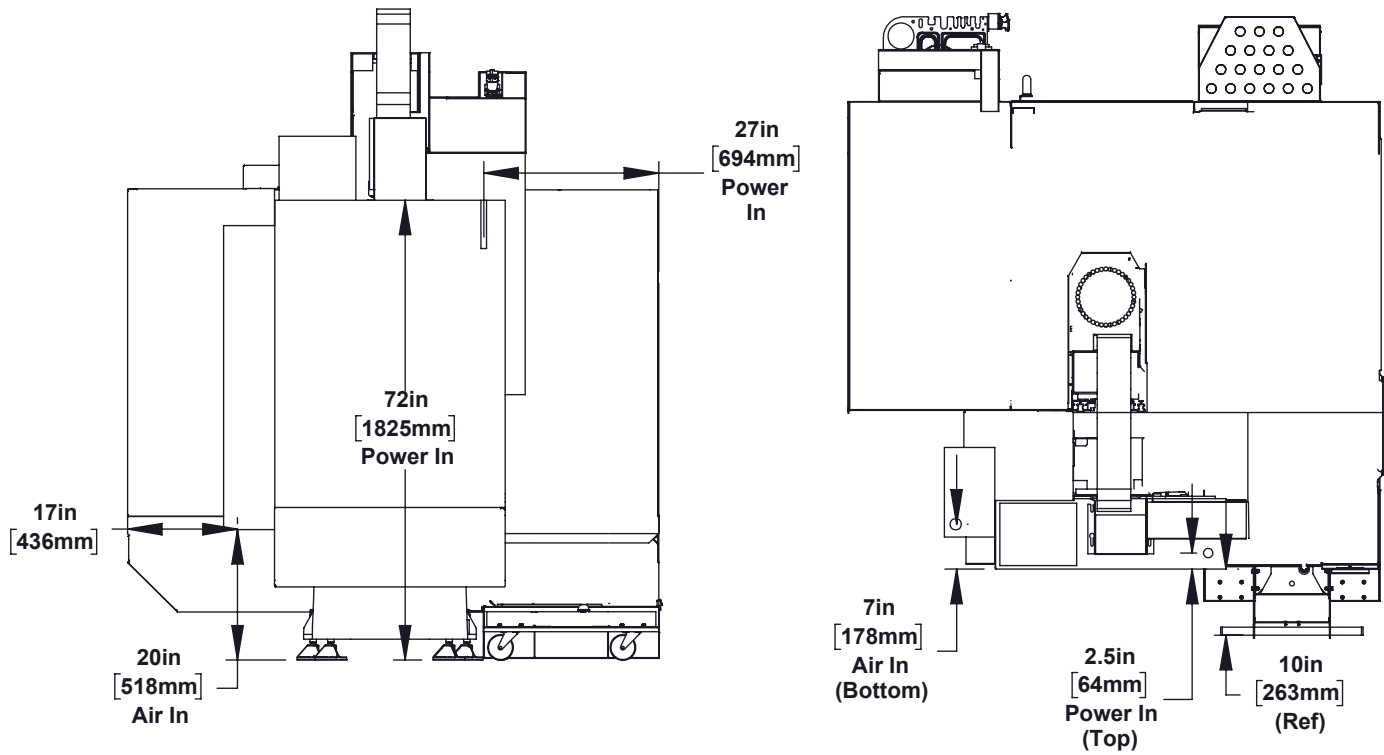

All dimensions based on stackup of sheetmetal, subject to variation of 1/2" (13 mm)

ANCHORING PATTERN

Anchor Hole Detail:
 ∅ 0.625in [16mm]
 ▽ 2.0in to 2.25in
 ▽ 51mm to 57mm

Anchoring kit available
 includes floor template
 & hardware needed

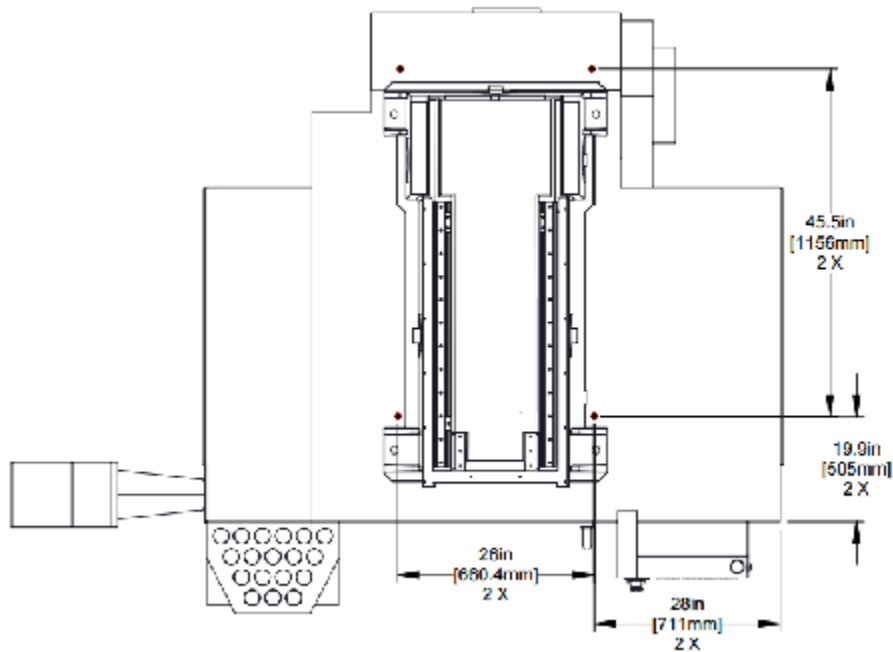

Note: Machine must be placed on one continuous concrete slab. Slab should extend 12in [305mm] beyond anchor holes in all directions

X & Y AXIS TRAVELS

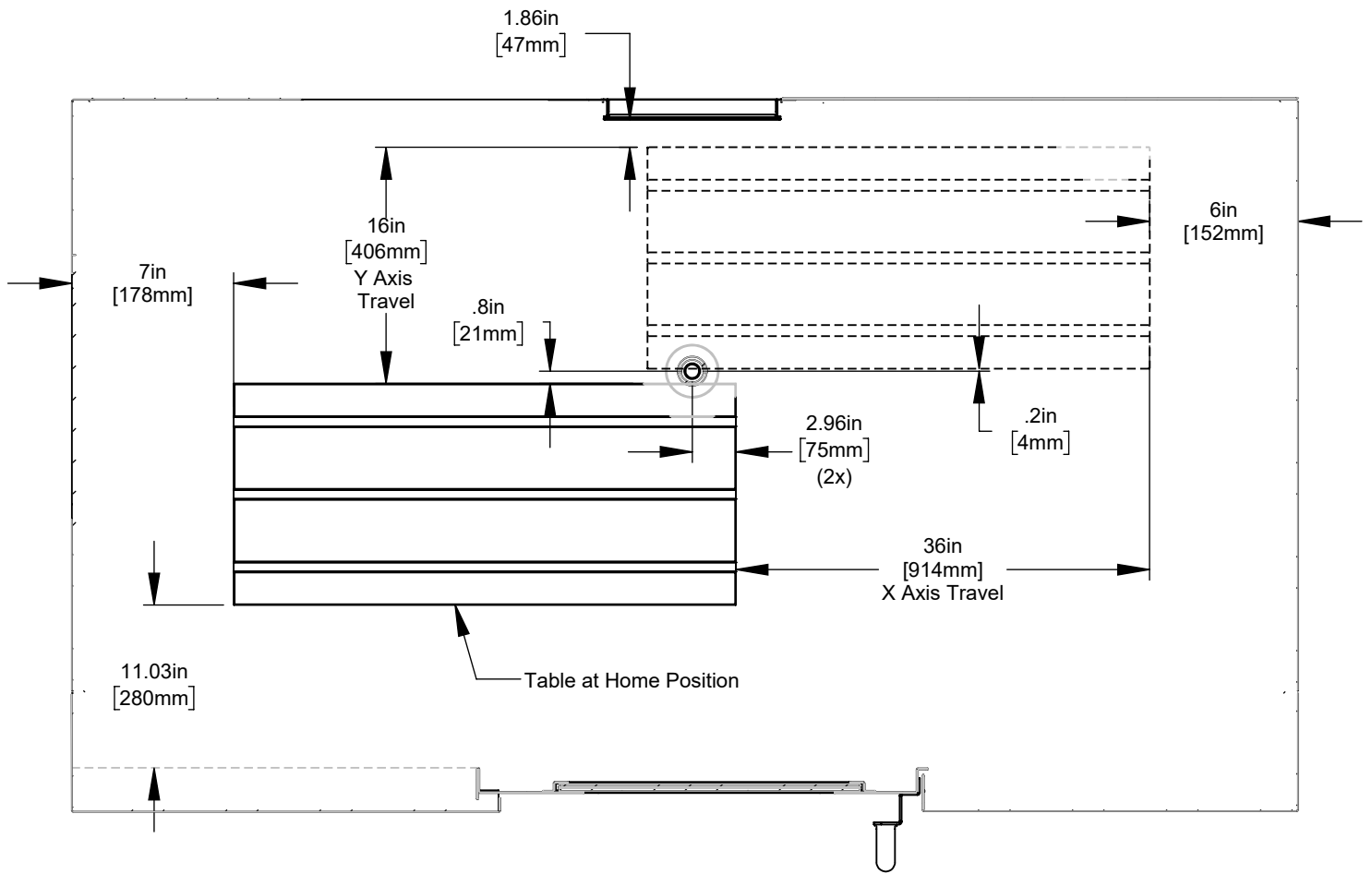

Z-AXIS TRAVEL

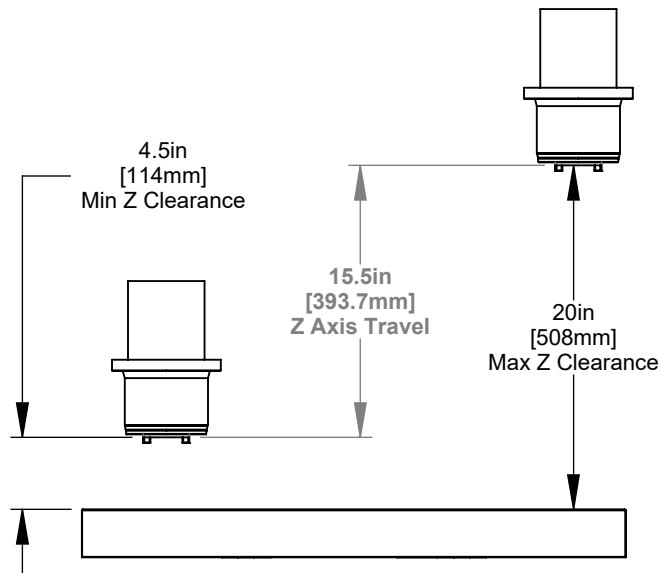

TABLE

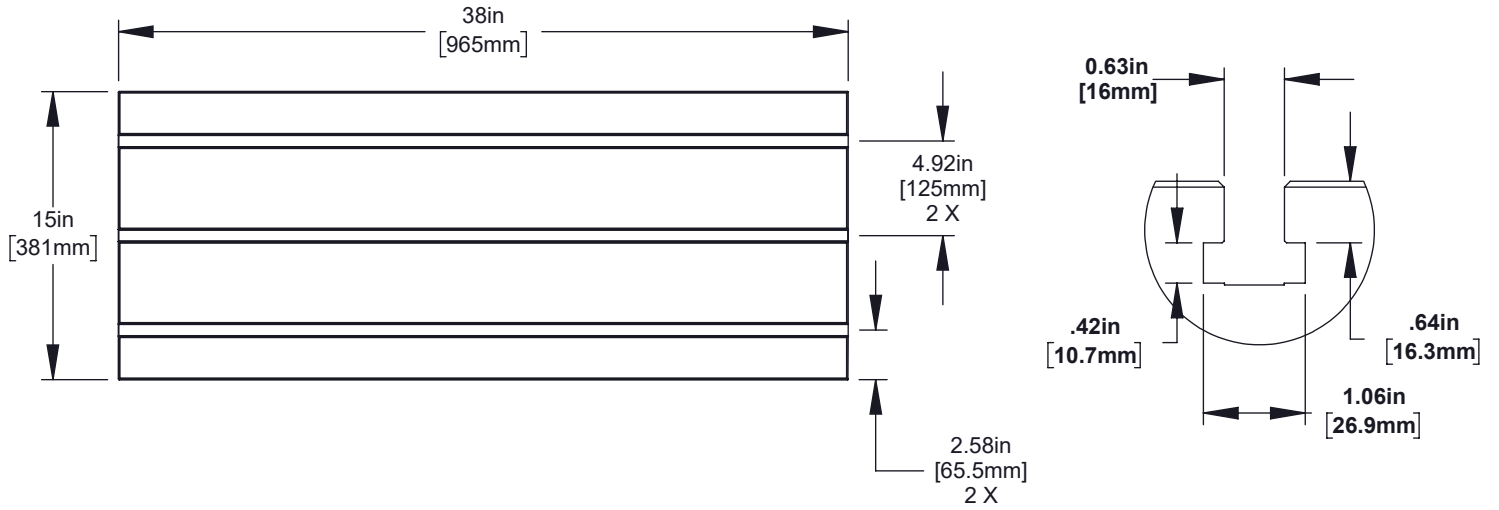

All dimensions based on stackup of sheetmetal, subject to variation of 1/2" (13 mm)

TOOL CHANGER

