

Hydraulic Unit

Optimal layout displayed, based on the hoses and connections provided for the hydraulic Unit and Coolant tank.

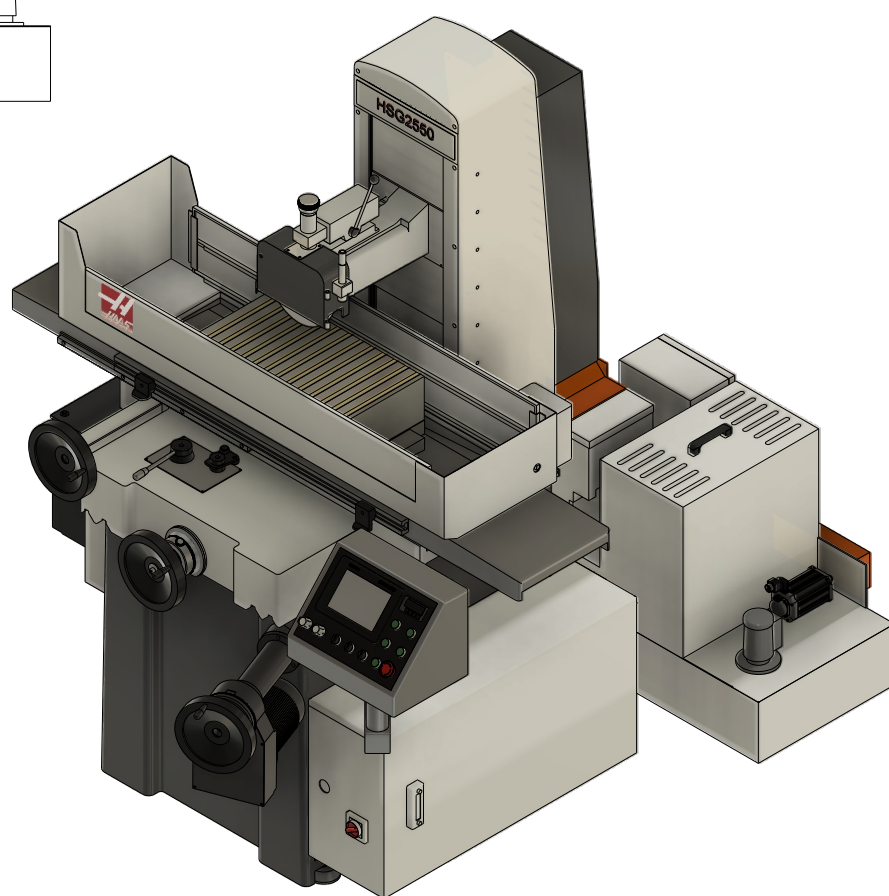

Coolant Tank

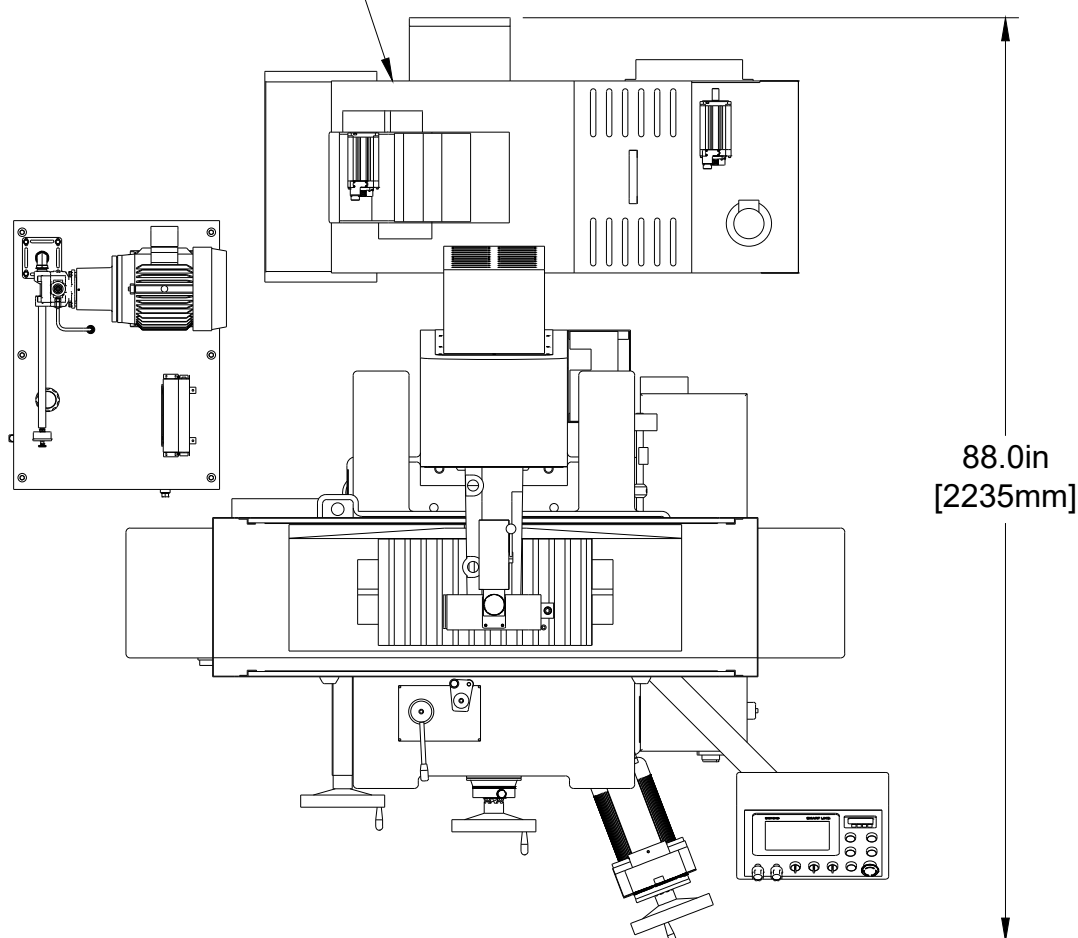

88.0in
[2235mm]

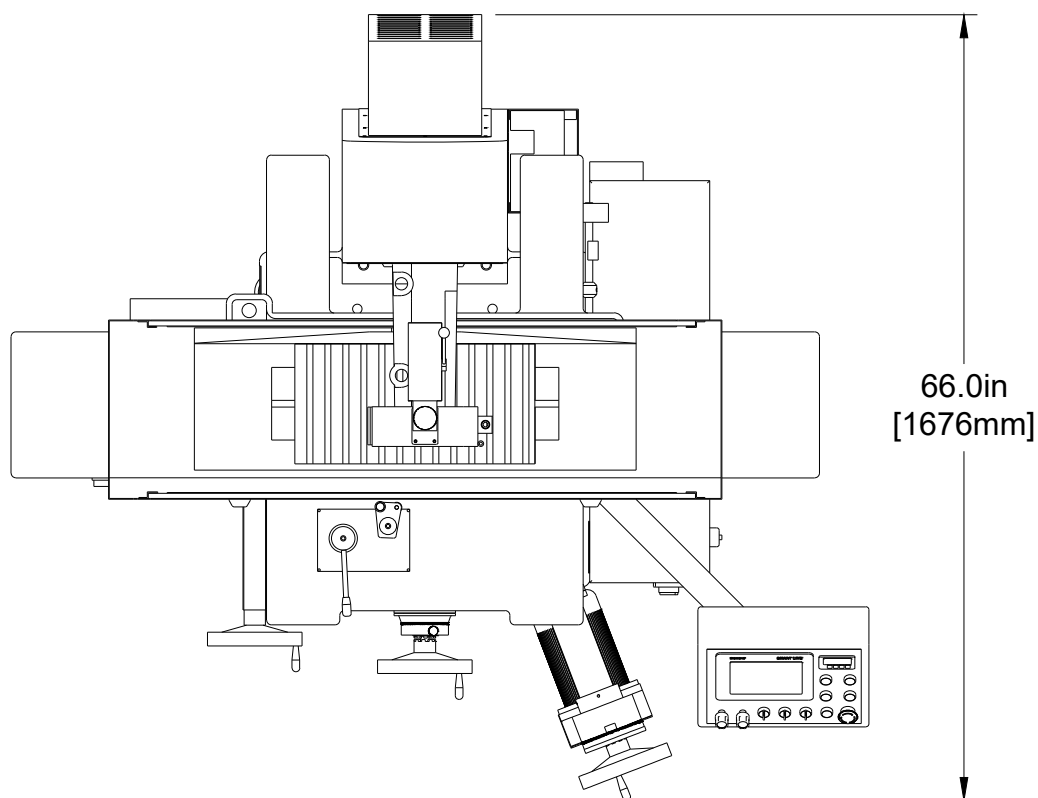
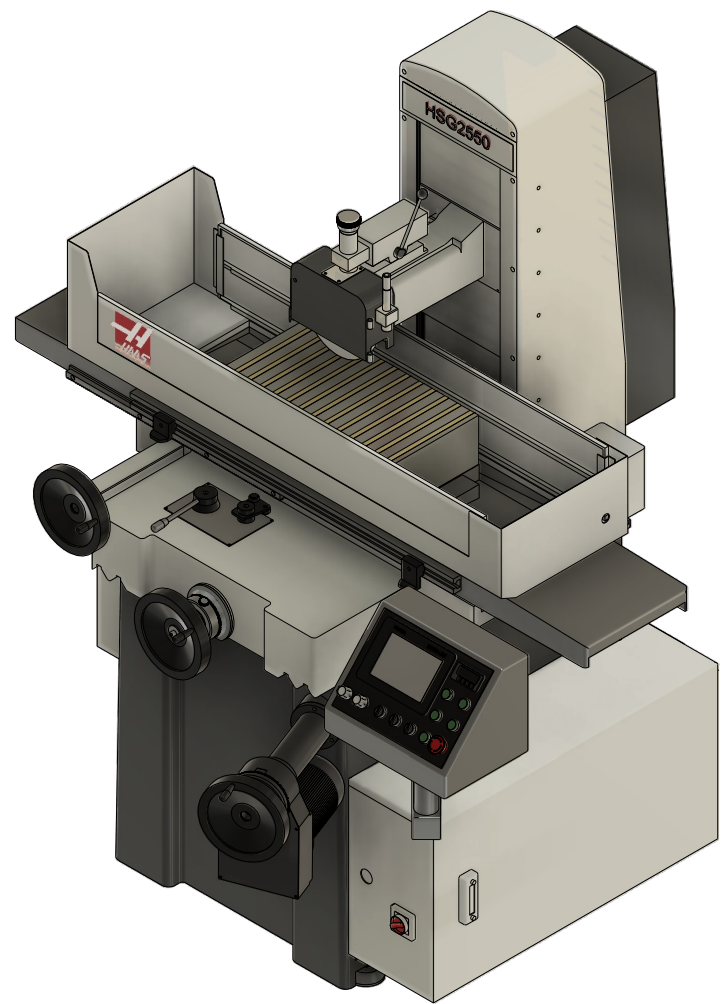
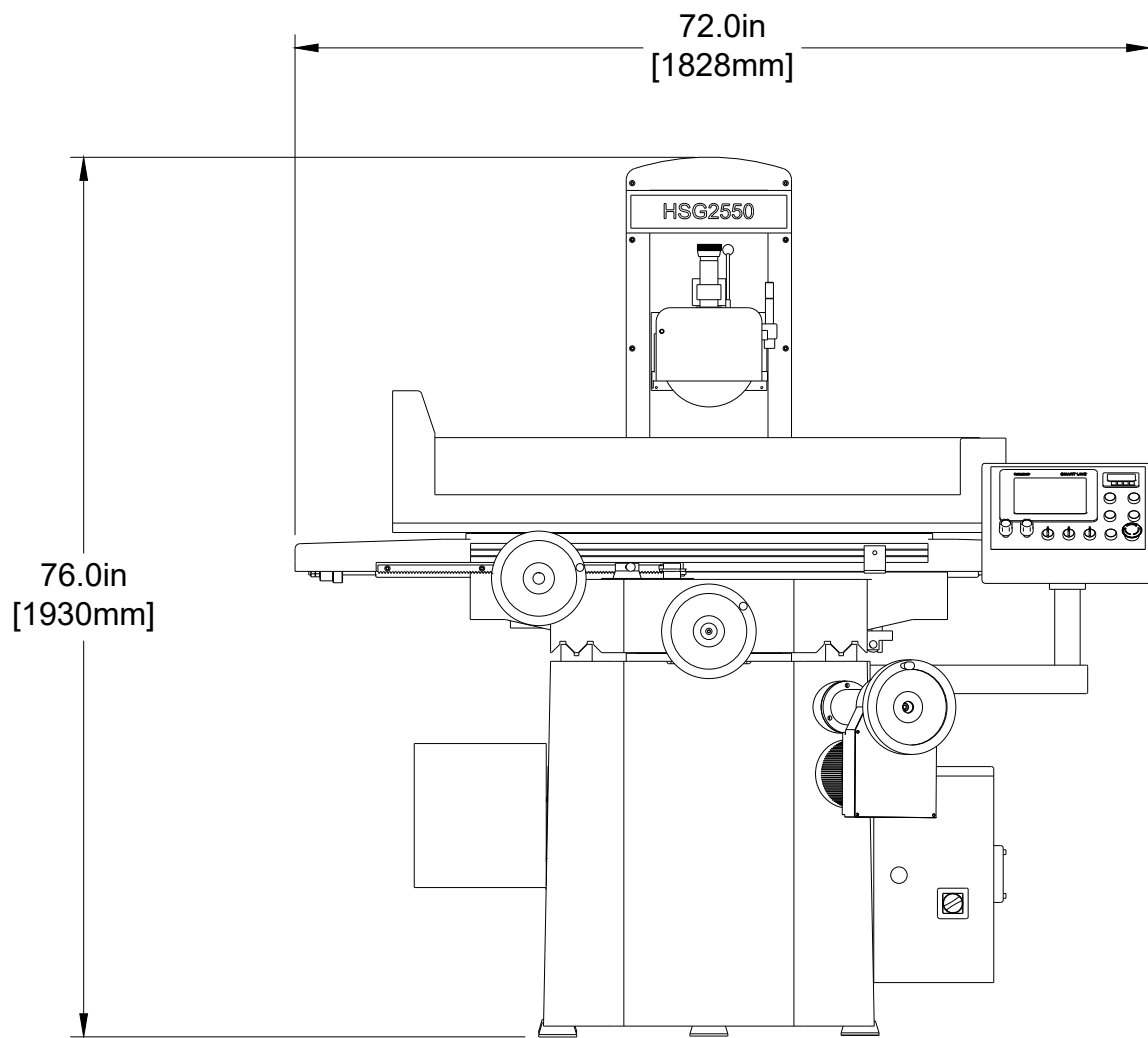

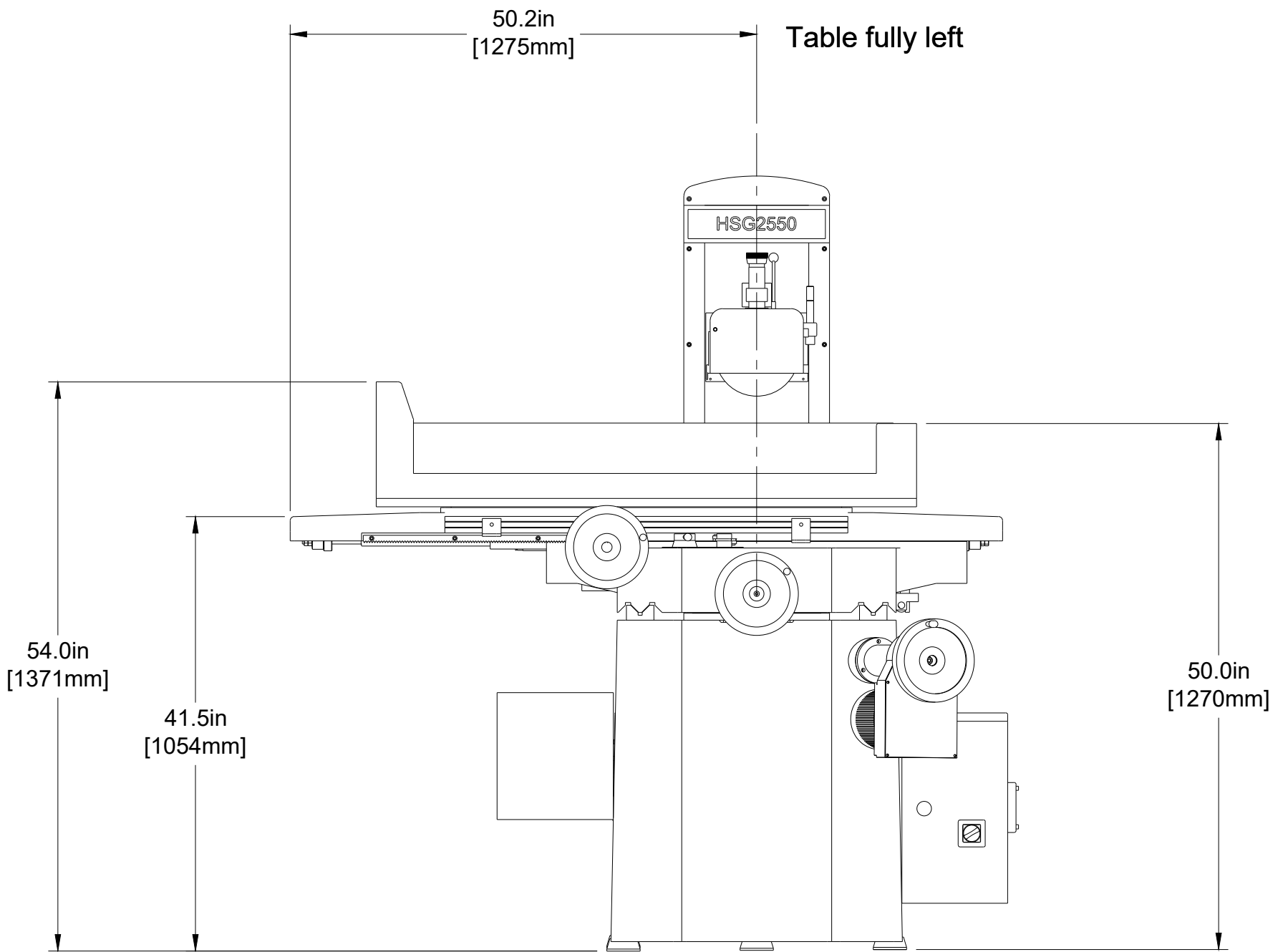

Max longitudinal table (X-axis) travel of 22.0" (+/- 11.0") may need to be considered when accounting for floor space. A total of 100.4" (+/- 50.2") required at the heights noted.

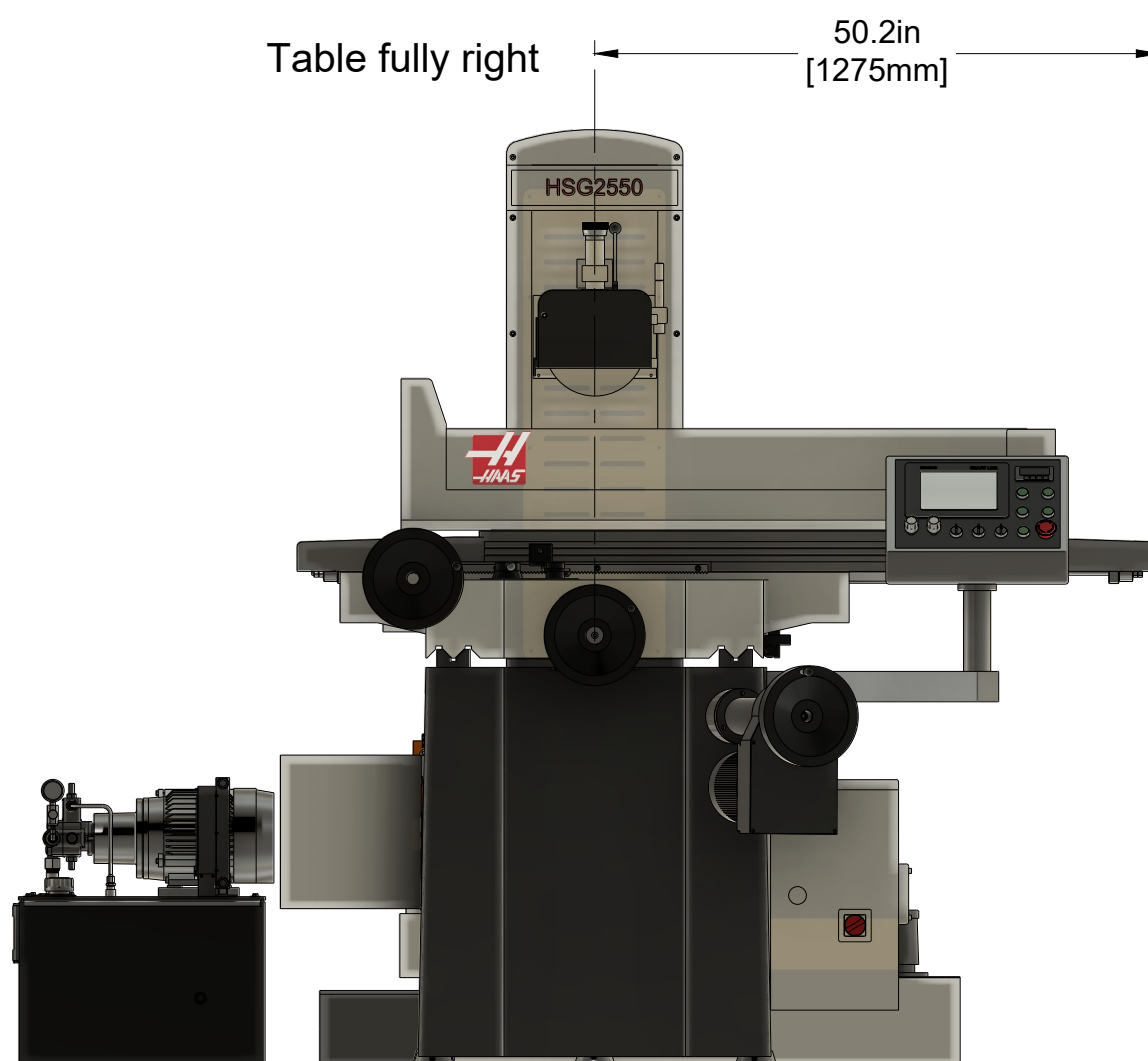



Standard 7.87" (200mm) diameter wheel provided with the machine.
8.0" Wheels available on Haas Tooling

