

FRONT VIEW - OPERATIONAL DIMENSIONS

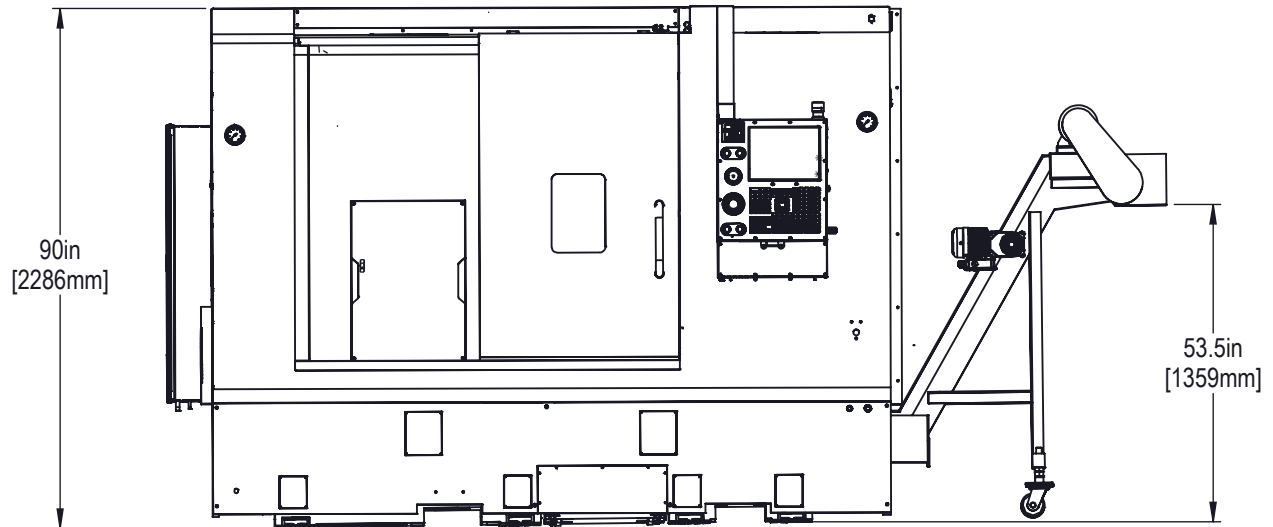

REFER TO THE INSTALLATION INSTRUCTIONS FOR STEP BY STEP GUIDANCE

TOP VIEW - OPERATIONAL DIMENSIONS

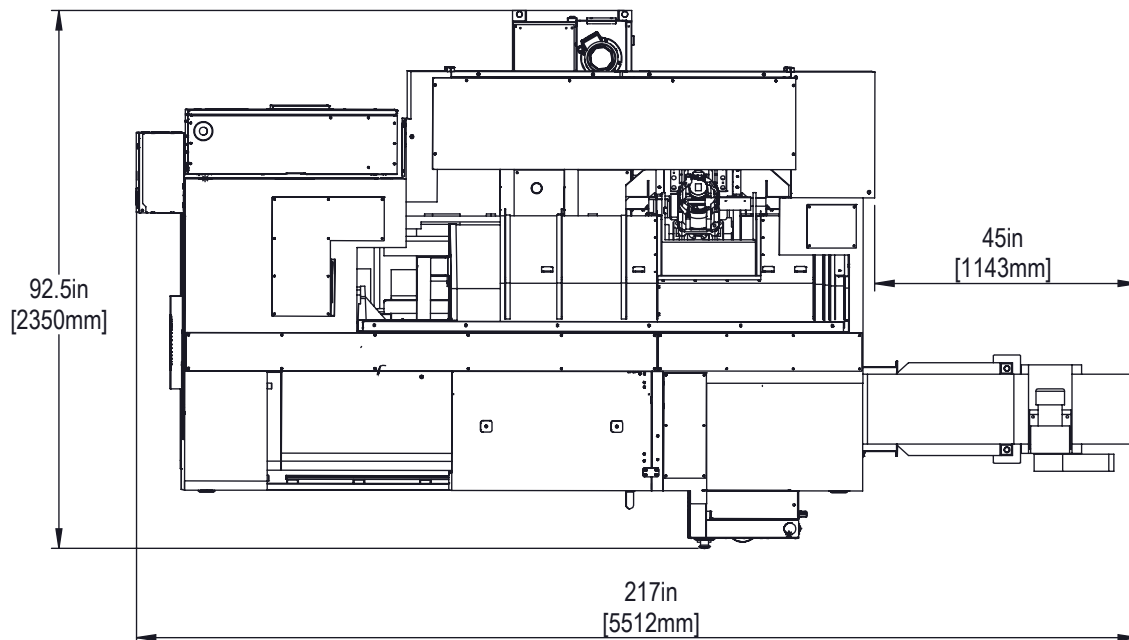

DRAWING NOT TO SCALE

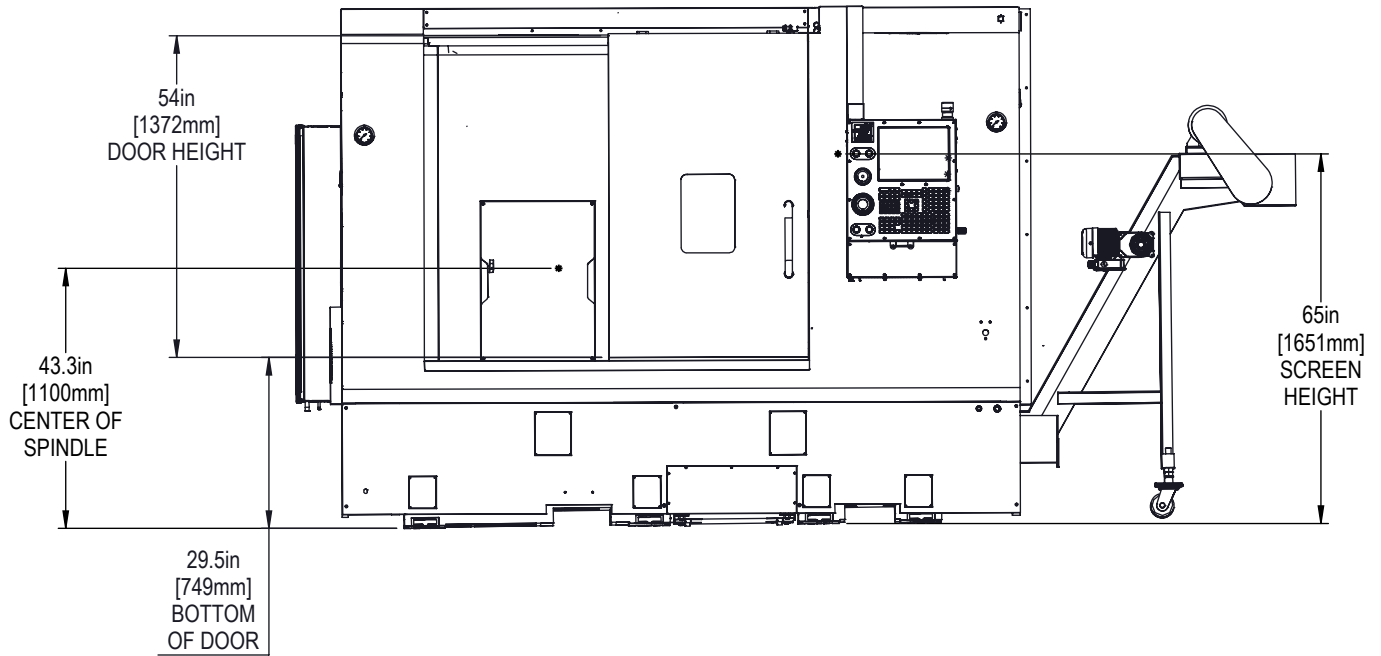

DRAWINGS NOT TO SCALE

MINIMUM 36in [914mm] CLEARANCE NEEDED FOR CABINET DOOR SWING

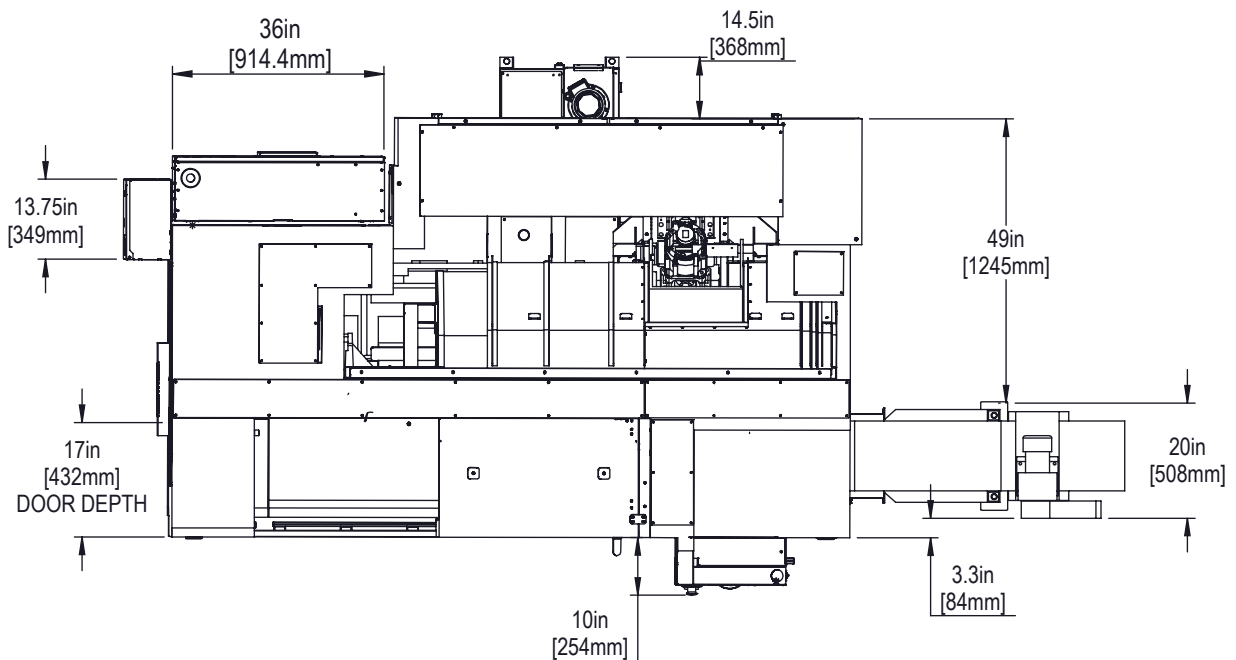

CONVEYOR REMOVAL DISTANCE IS 67in [1702mm]

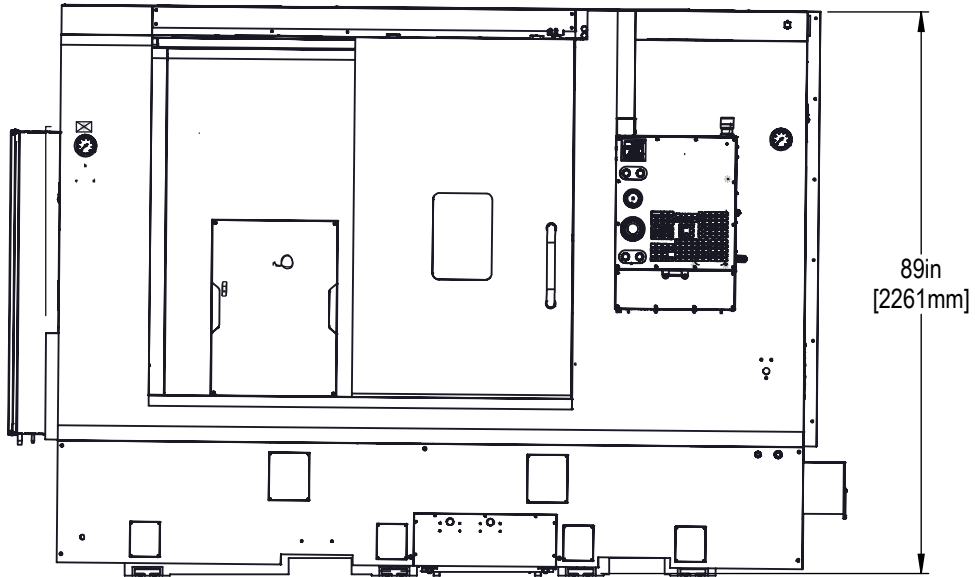

DIMENSIONS SHOWN FROM THE BOTTOM OF THE BASE TO THE HIGHEST POINT

LEVELING SCREWS AND PADS ARE REMOVED TO REDUCE HEIGHT

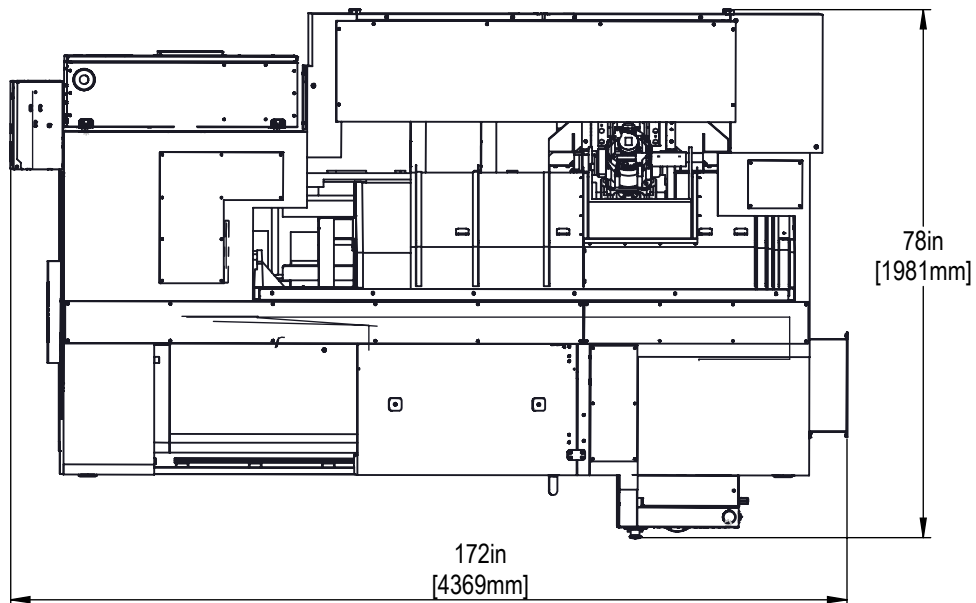

WHEN THE CONVEYOR OPTION IS SELECTED, IT SHIPS IN THIS VERTICAL POSITION