

Installed Dimensions

Note: Vacuum bags shown fully inflated.

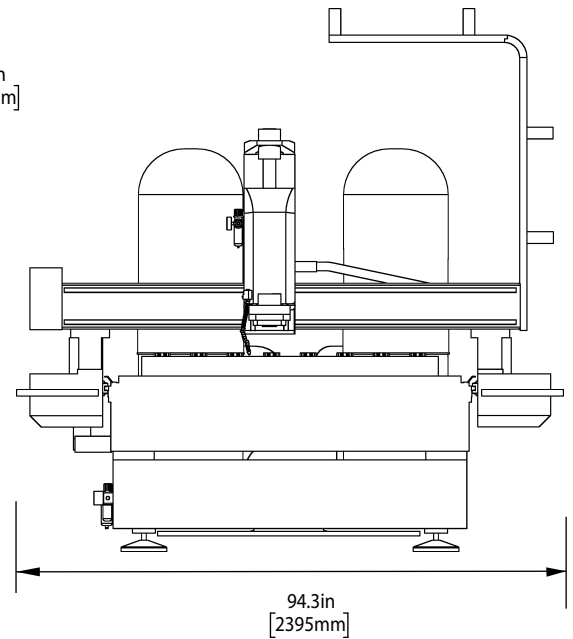
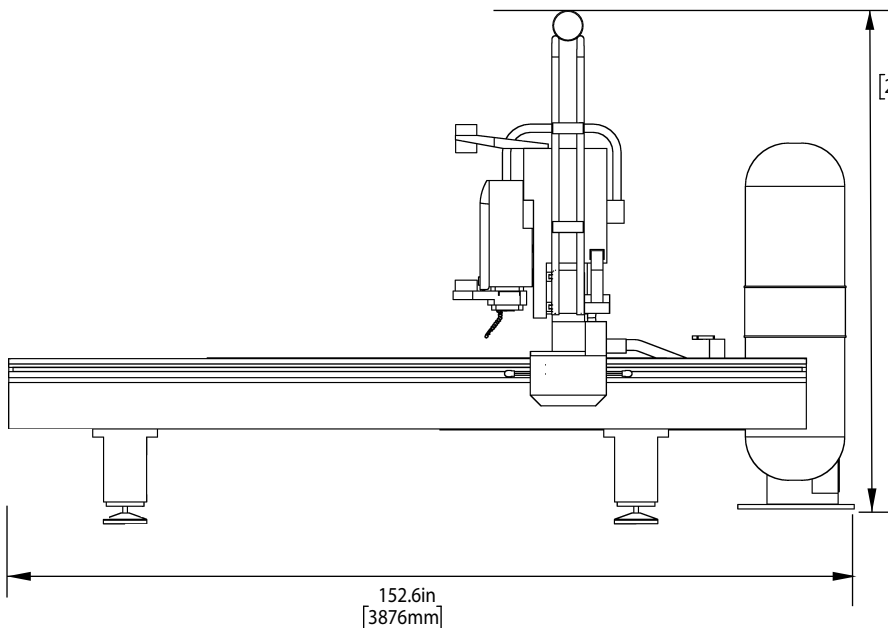
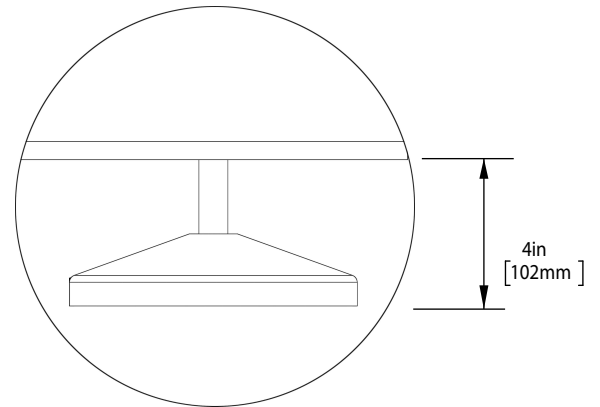
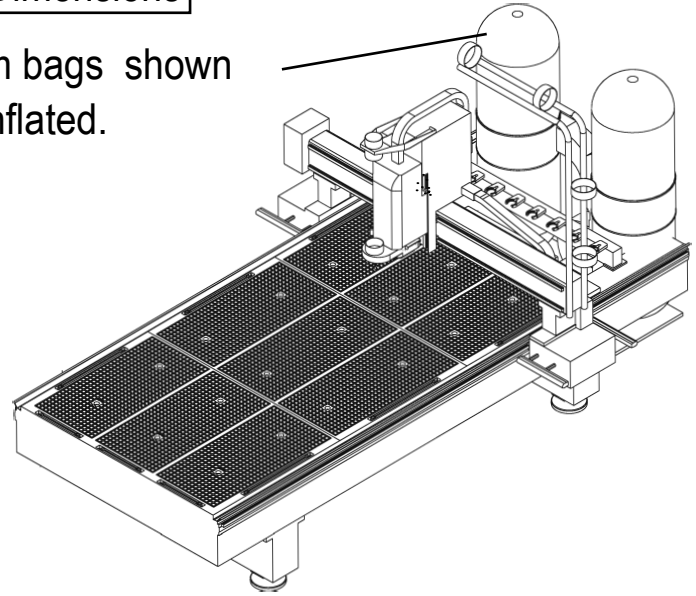
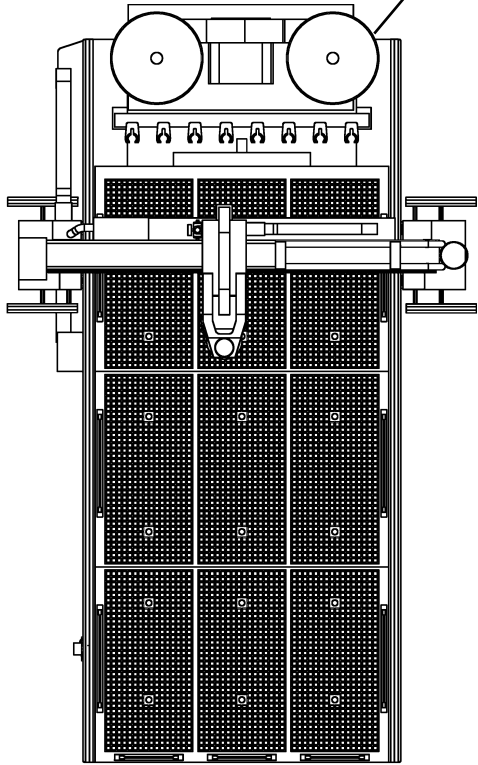

All dimensions based on stackup of sheetmetal, subject to variation of 1/2" (13 mm)

* Due to continual product improvements, machine dimensions are subject to change without notice.

Height Breakdown

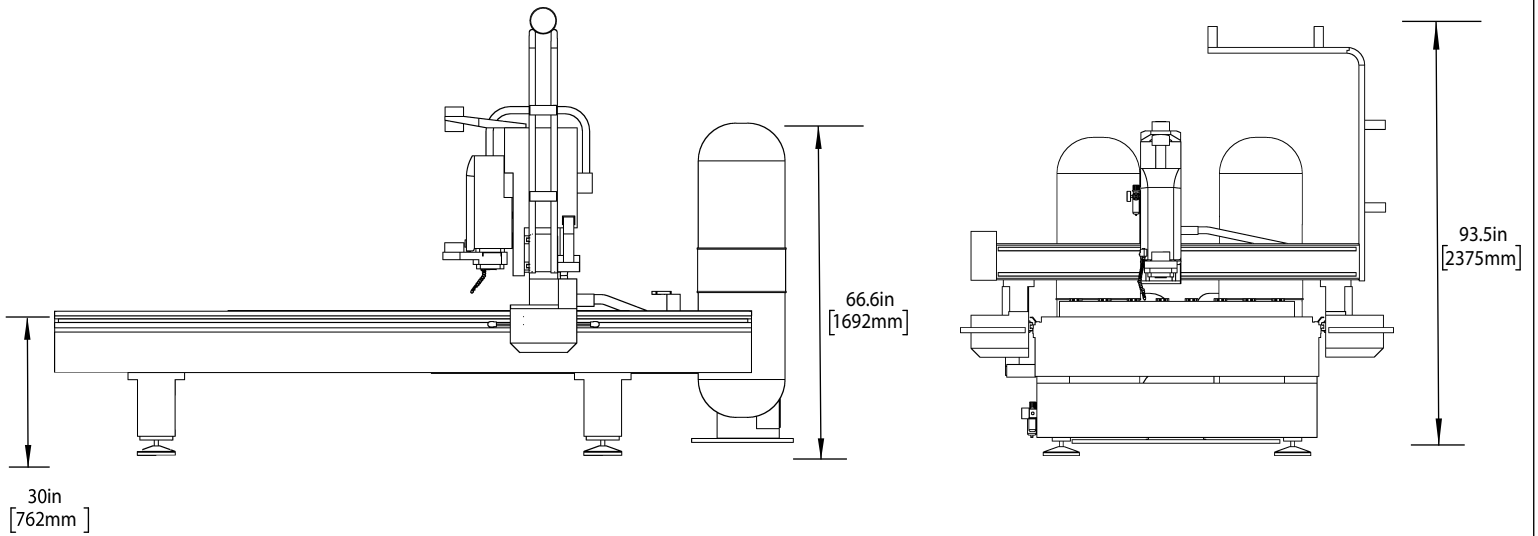

All dimensions based on stackup of sheetmetal, subject to variation of 1/2" (13 mm)

Depth and Width Breakdown

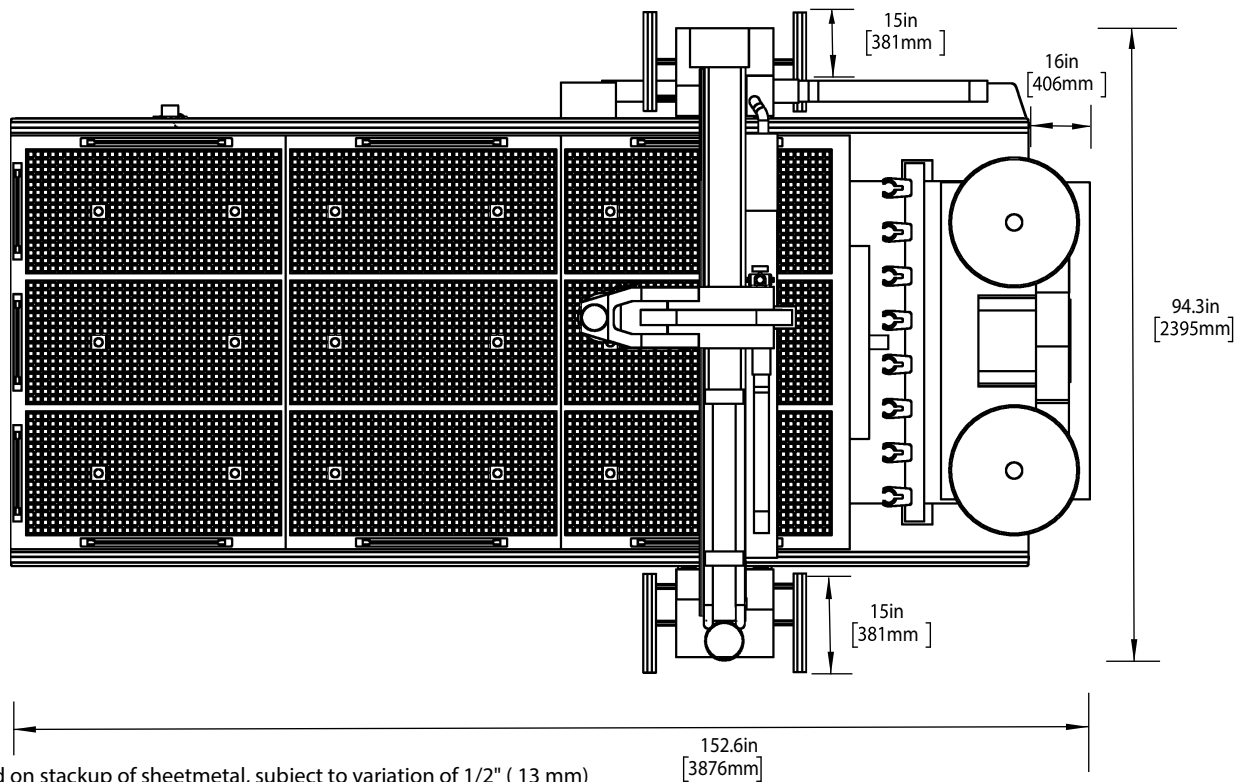

All dimensions based on stackup of sheetmetal, subject to variation of 1/2" (13 mm)

*Due to continual product improvements, machine dimensions are subject to change without notice.

Shipping Dimensions

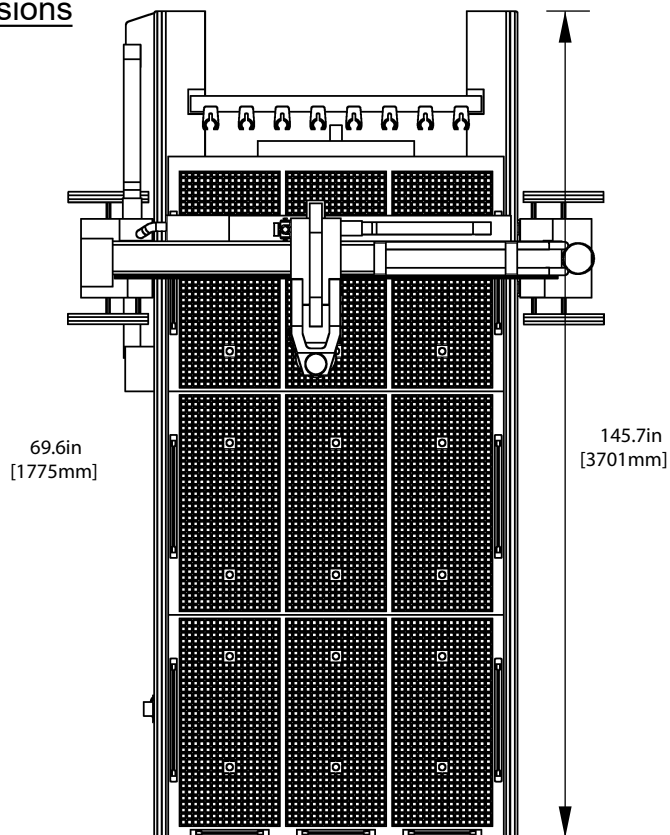
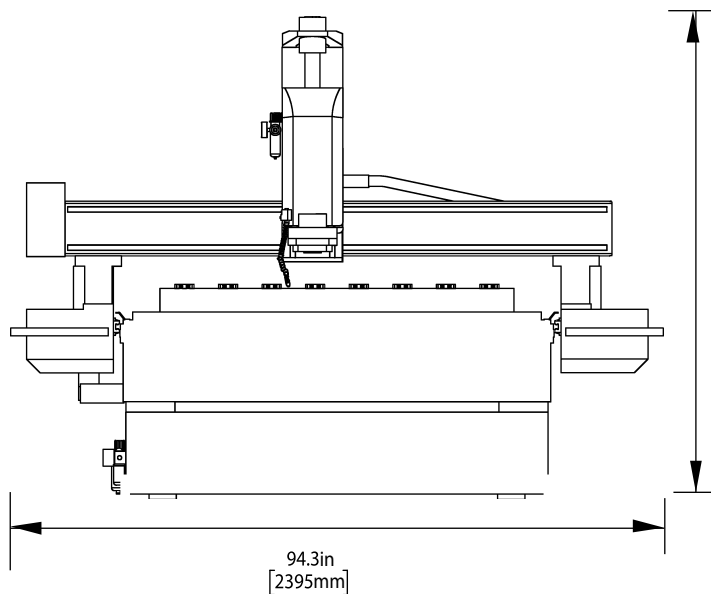

Power

Side View

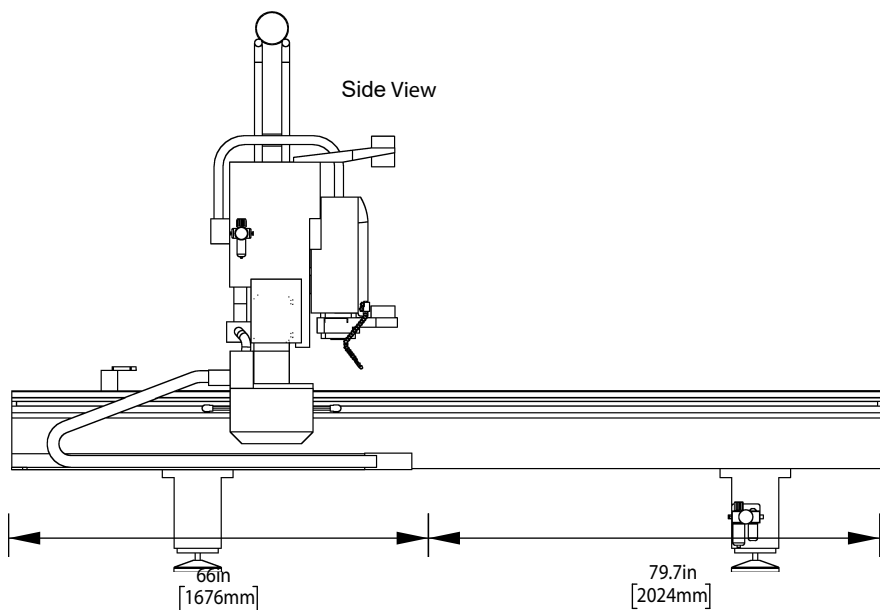

Front View

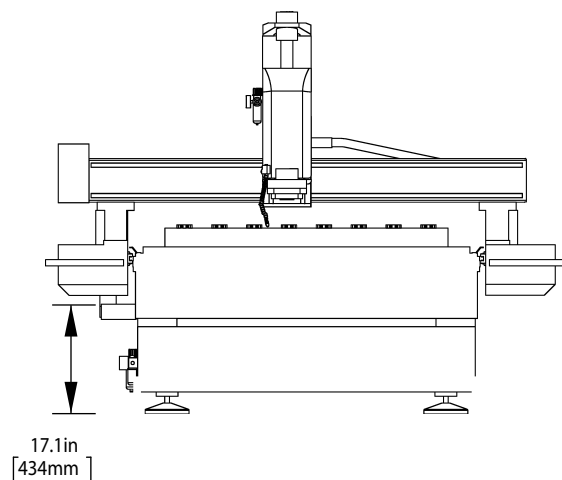

Note

1. No air connection. Sheet Router does not require compressed air or coolant

Control Panel

Box Dimensions

Vacuum Unit

Note: Vacuum bags shown fully inflated.

COMING SOON

67in
[1017mm]

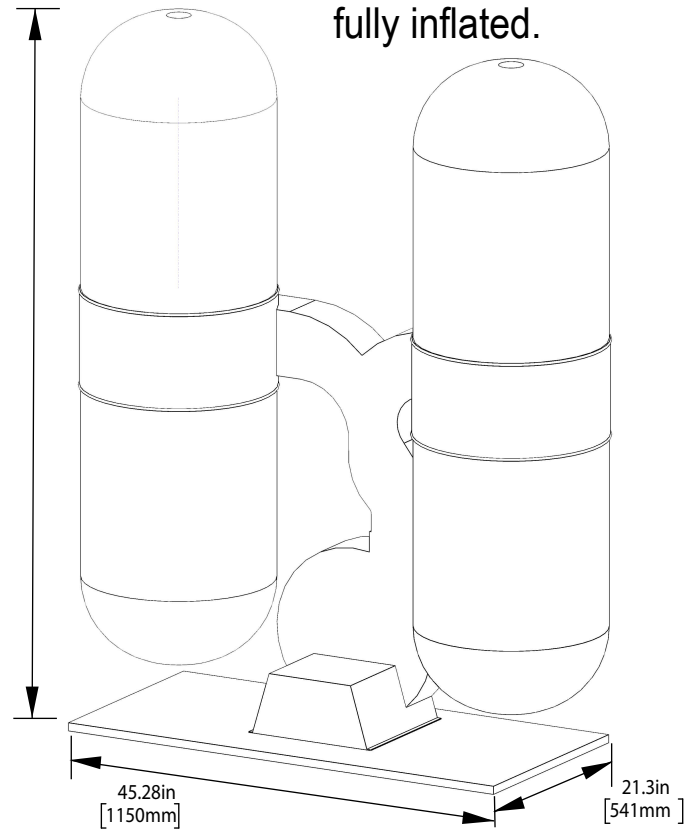

Cable And Hose Lengths

COMING SOON

X&Y-Axis Clearance

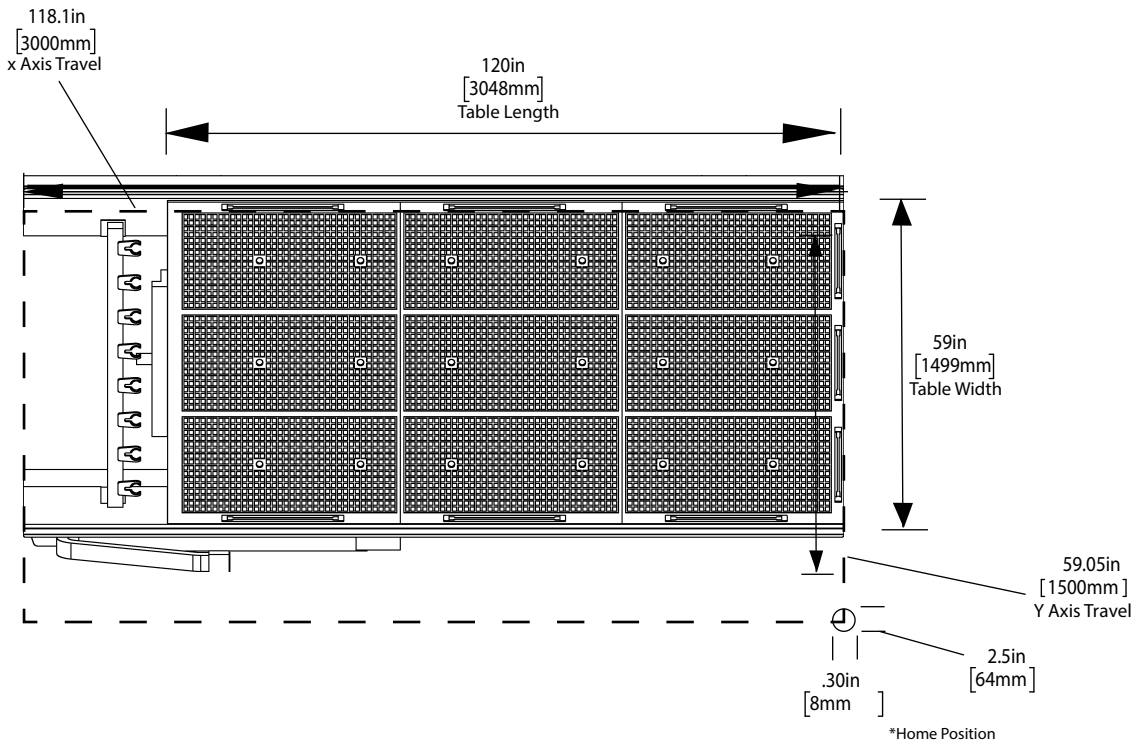

Z-Axis Clearance

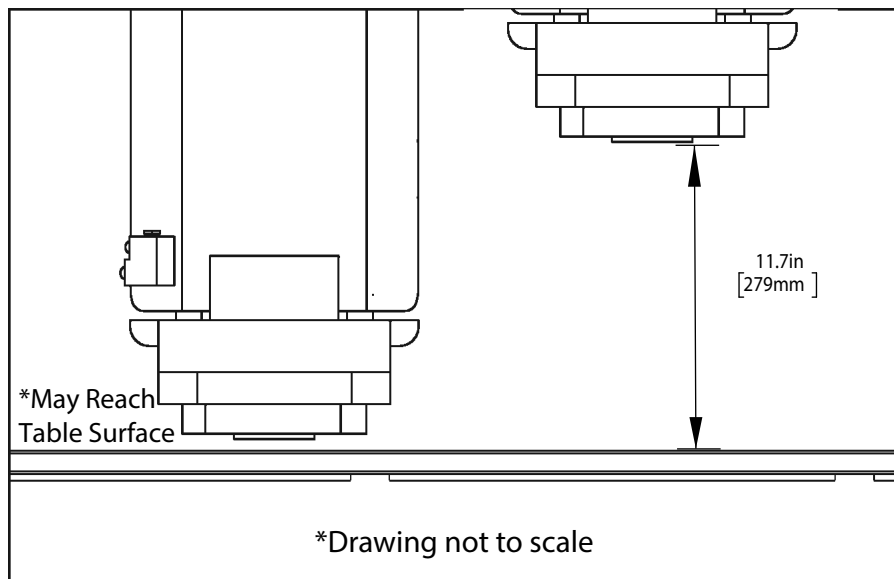

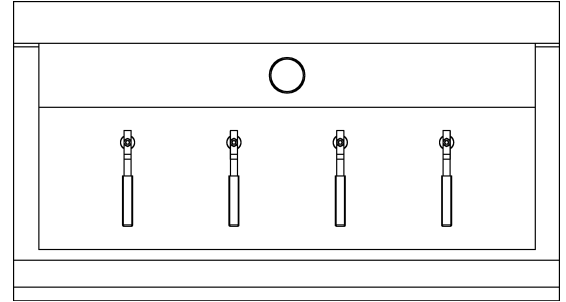
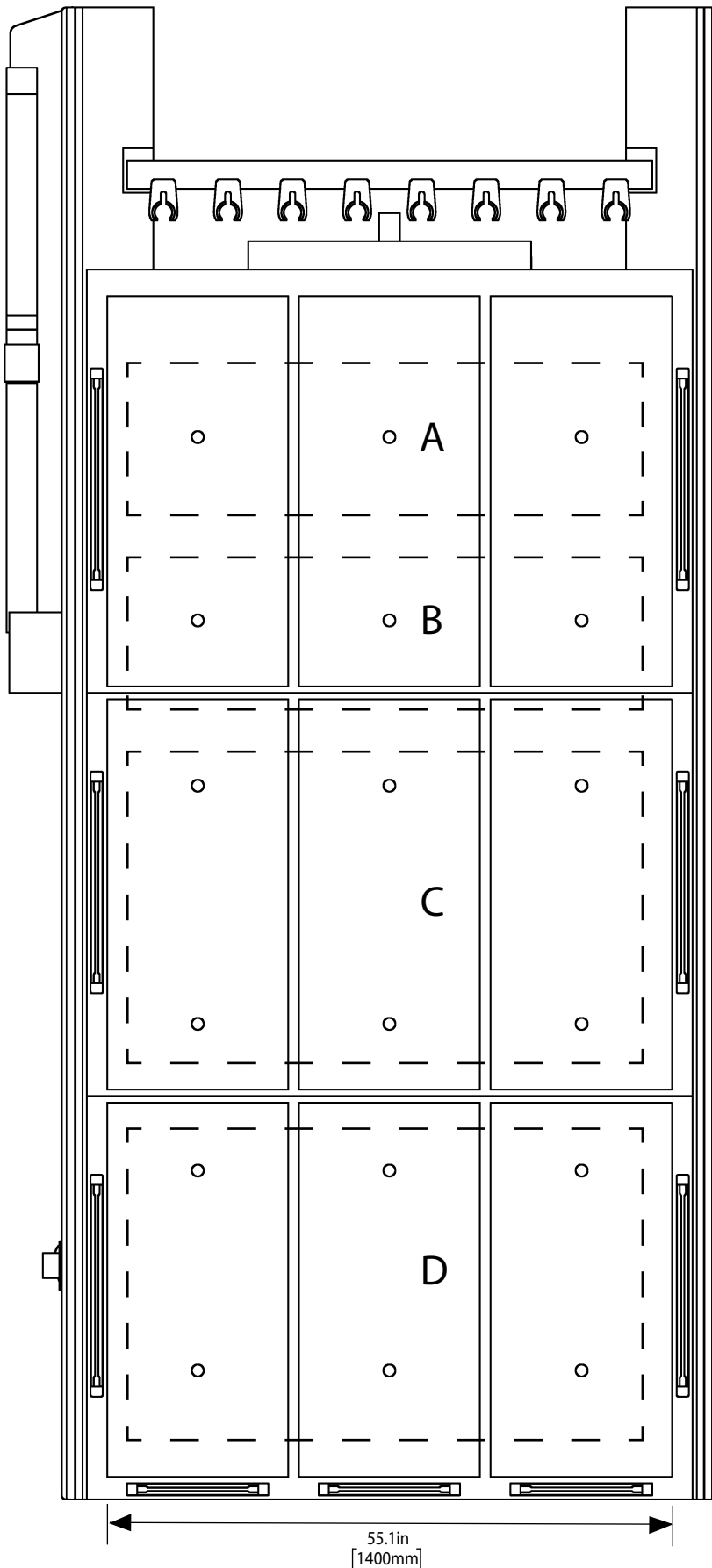

A B C D
There are 4 Regions
that can be controlled
individually by the
handles as shown

Region A = 3 Vacuum Ports
Region B = 3 Vacuum Ports
Region C = 6 Vacuum Ports
Region D = 6 Vacuum Ports