

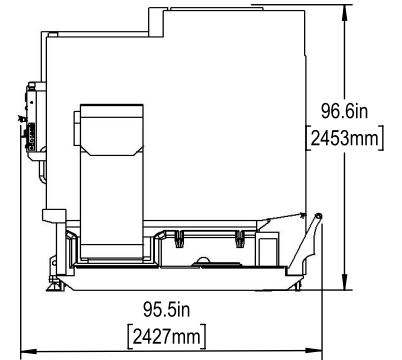

Installed Dimensions

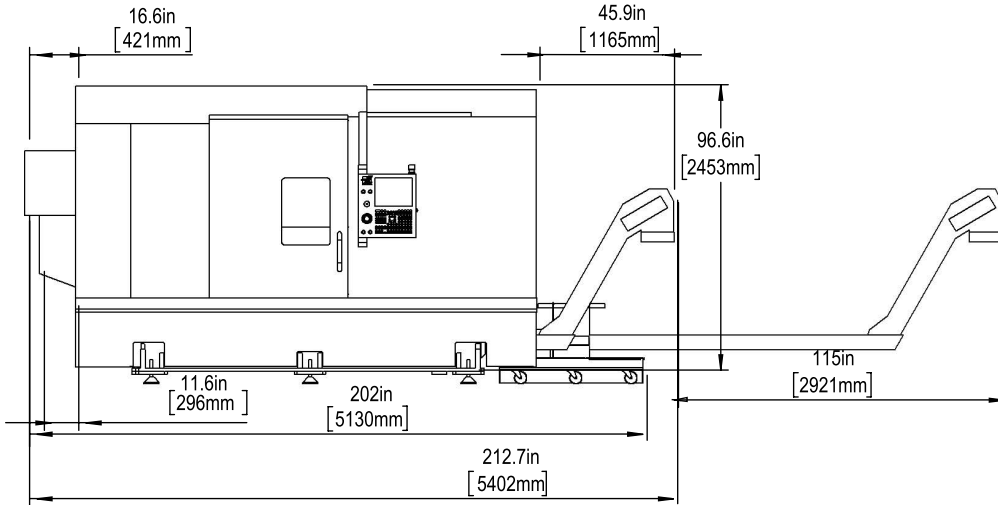
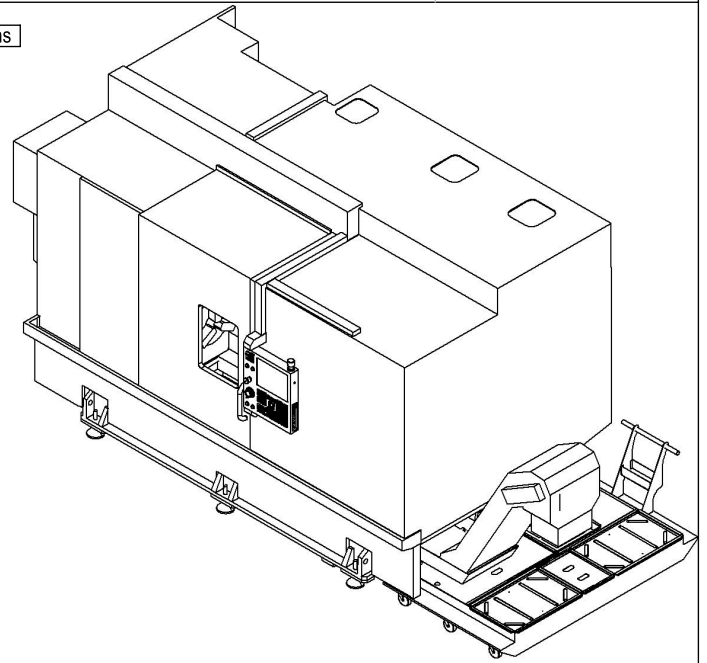
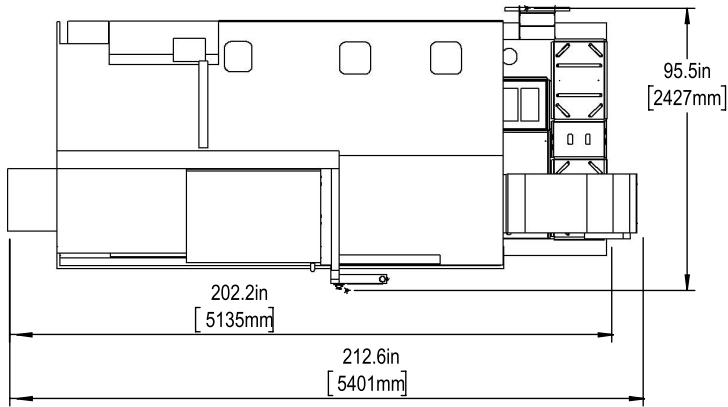

Shipping Dimensions

\*All Height Dimensions Based on Suggested Leveling Pad Height

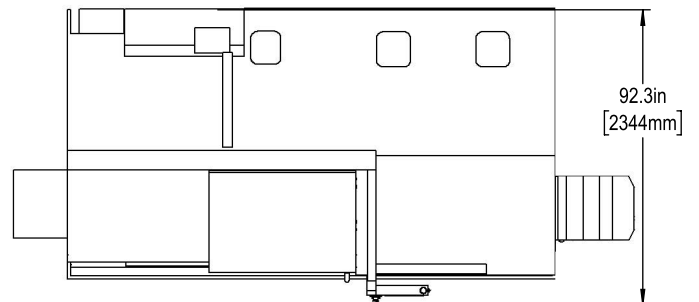
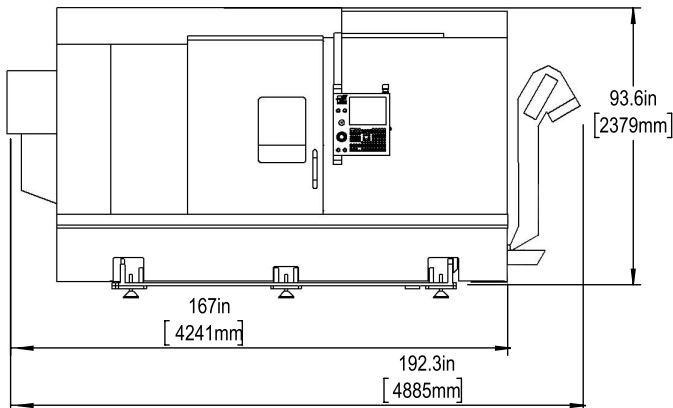

Air & Power

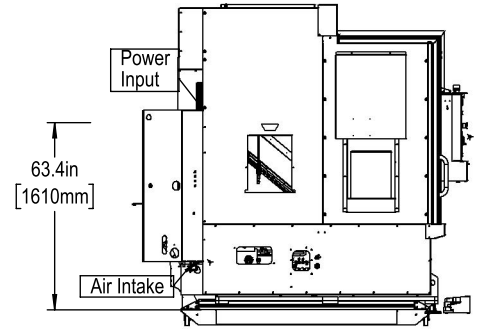
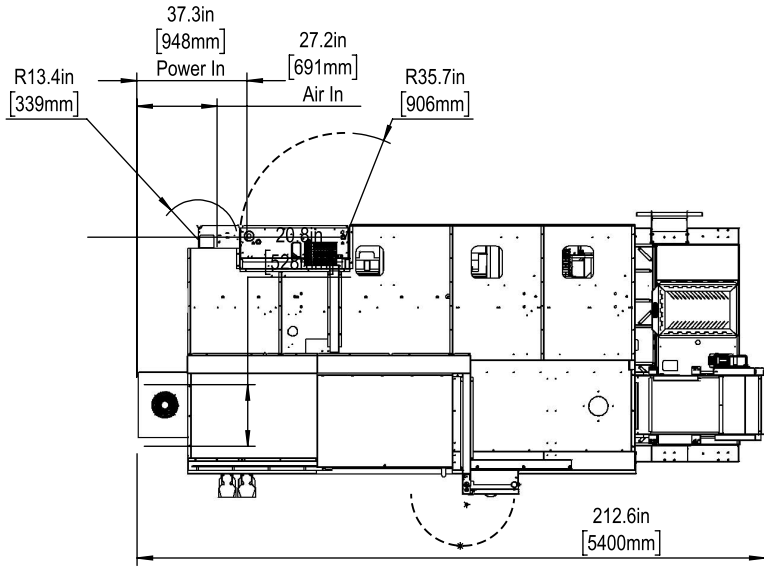

Maintain 3 feet [915mm] clearance to the nearest obstruction around all sides of machine perimeter for maintenance access

Note:

Machine must be placed on one continuous concrete slab. Slab should extend 12in [305mm] beyond anchor holes in all directions

Anchor Pattern

Anchor Hole Detail  
 Ø 0.625in[25mm]  
 ∇ 2.0in[50mm]-  
 ∇ 2.25in[57mm]

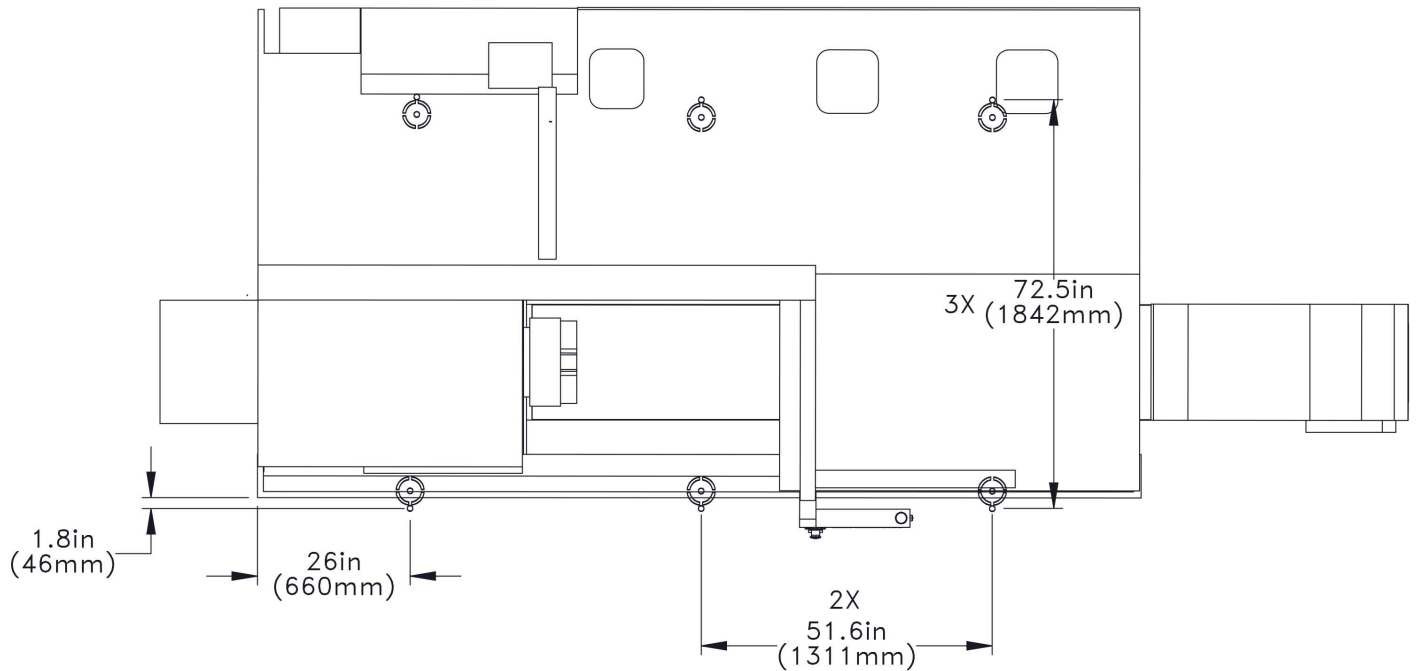

For precise locations and specifications please use template in Anchoring Kit found at Haascnc.com

Height Breakdown

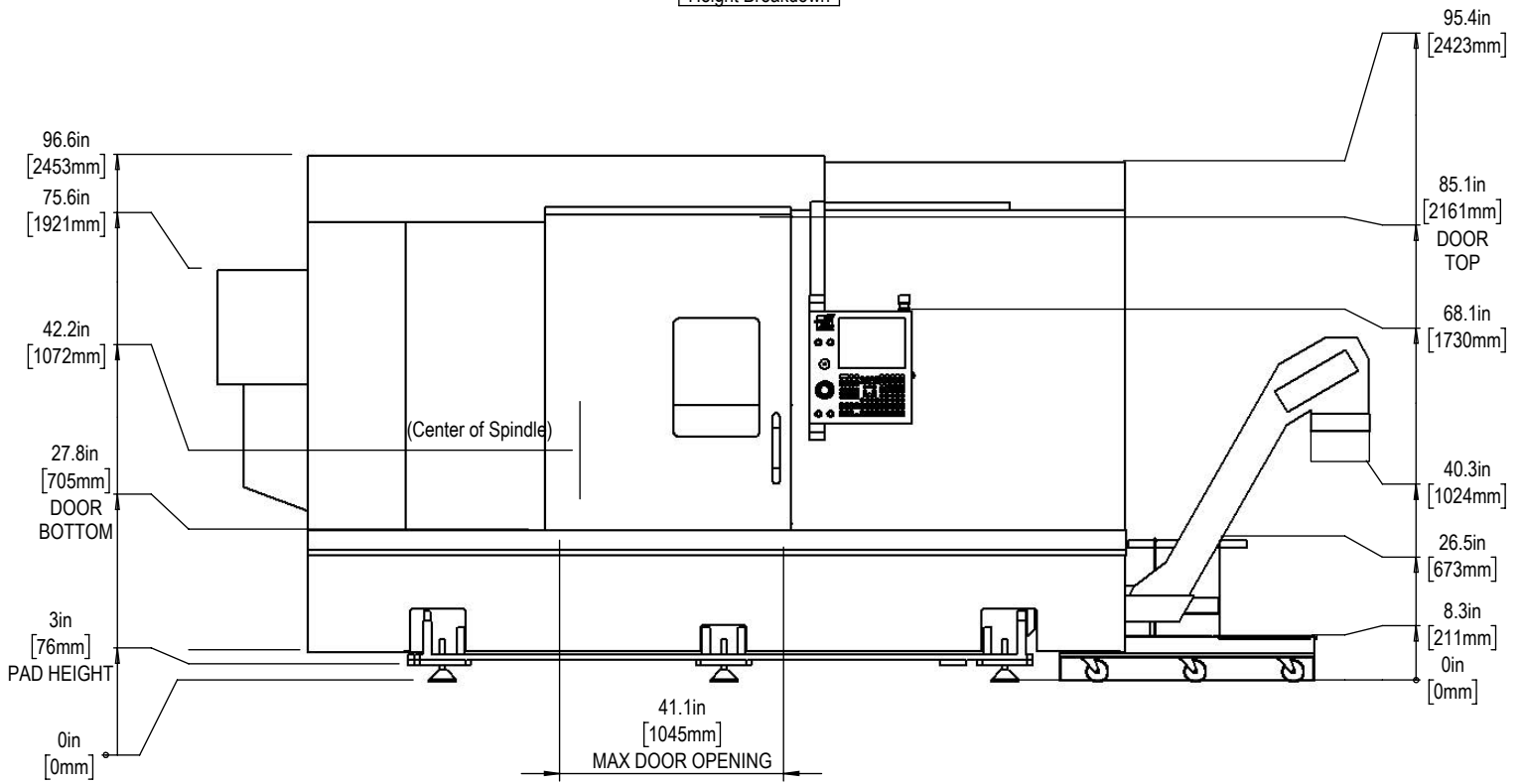

Depth Breakdown

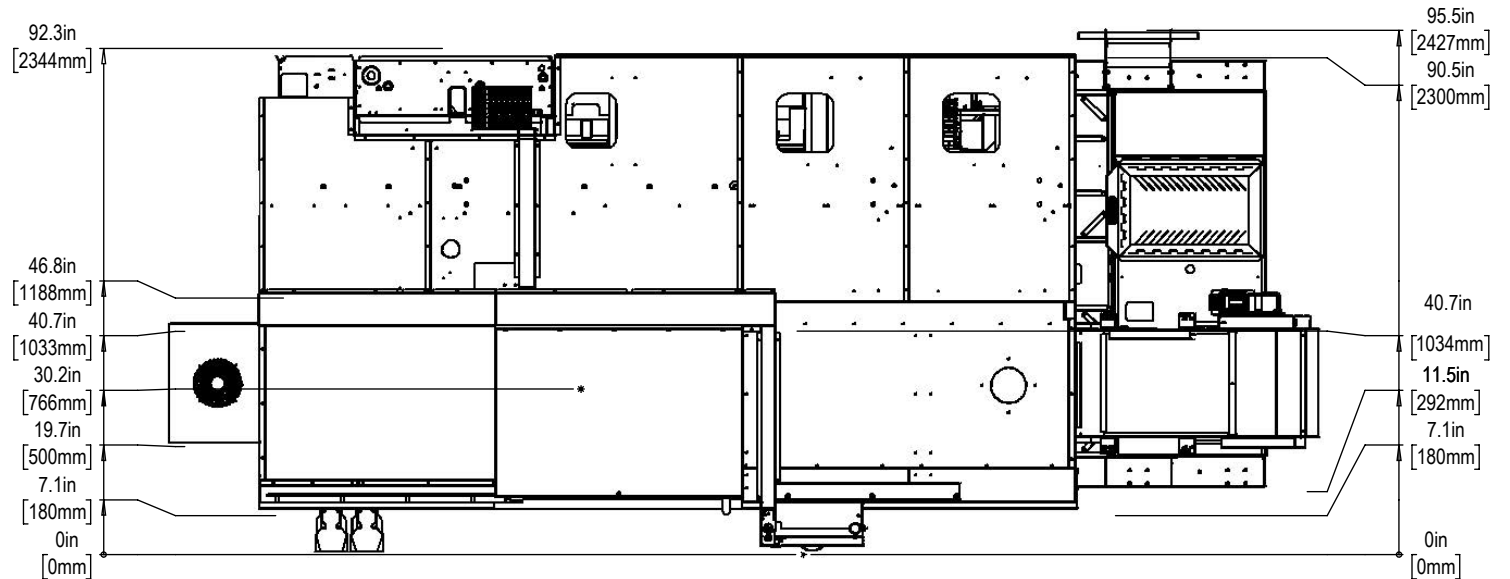

Axis Travel Diagrams

Steady Rest Travels

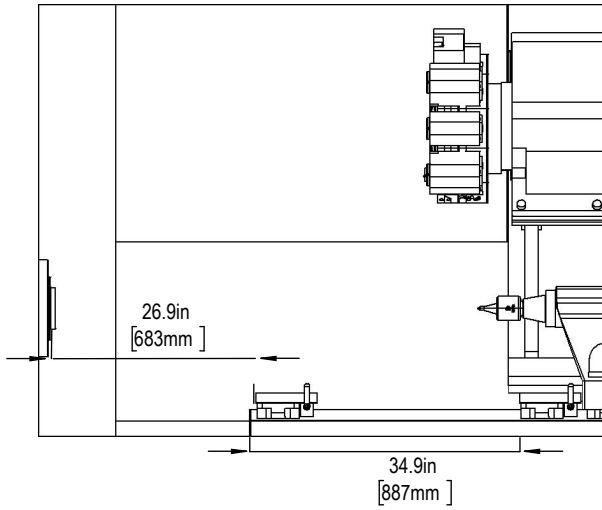

Tailstock Travels

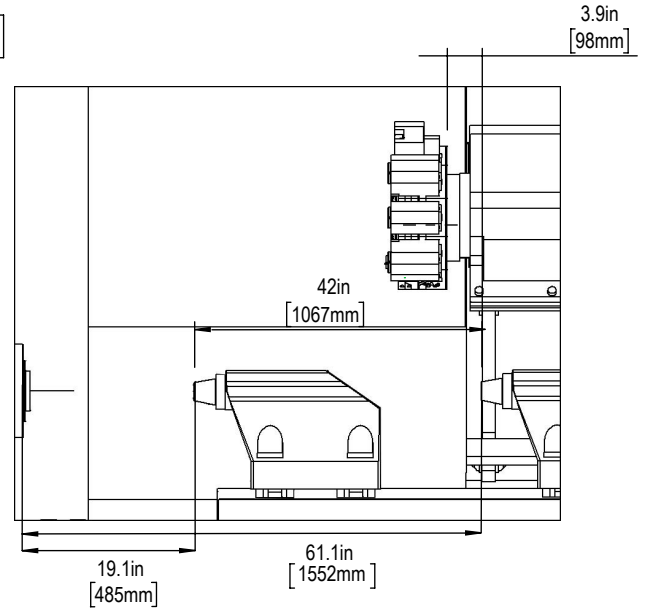

Turning Tool - ID

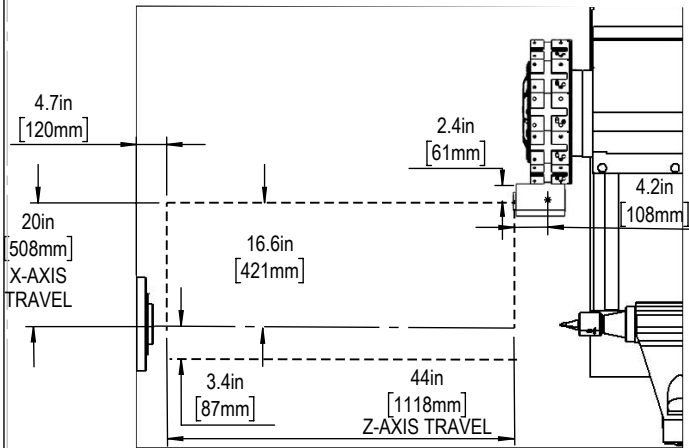

Turning Tool - OD

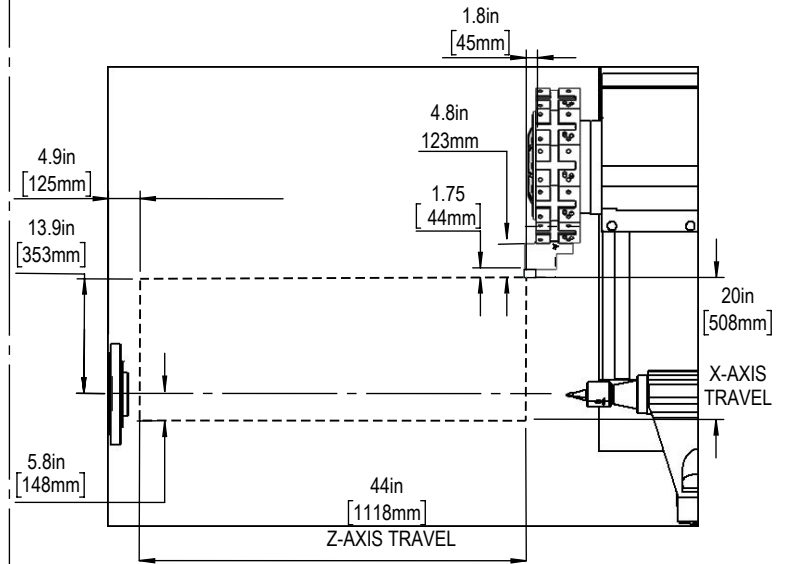

Optional Live Tooling - BMT75-STRAIGHT

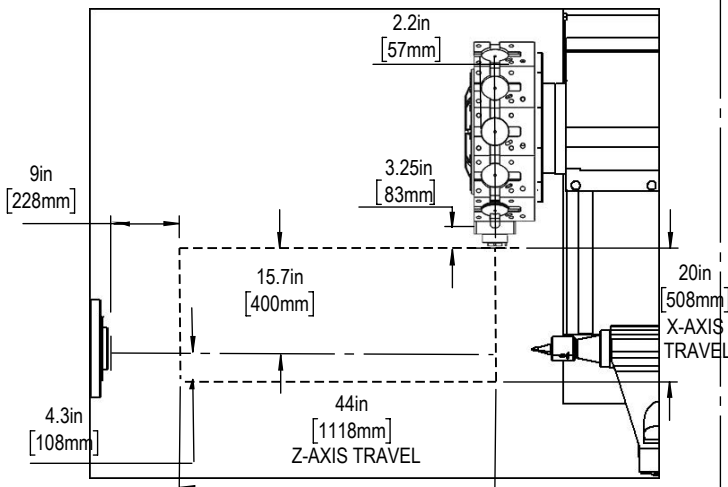

Optional Live Tooling - BMT75-90-DEGREE

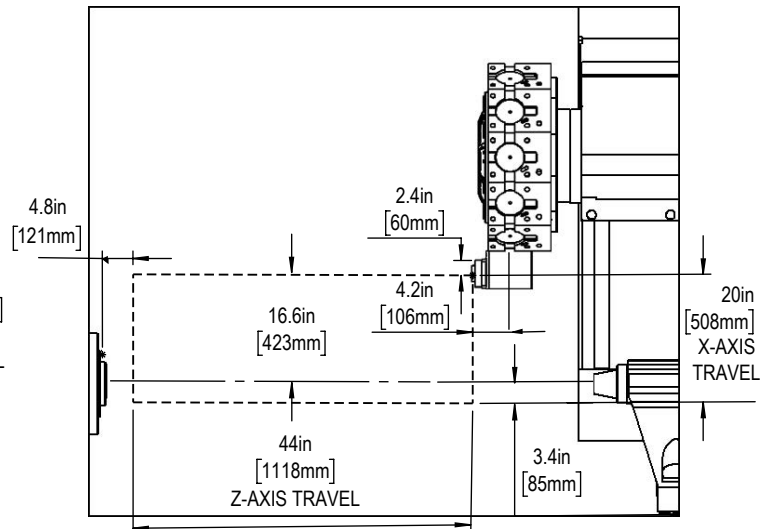

Tool Interference Layout

Y-Axis  
Travel  
Envelope

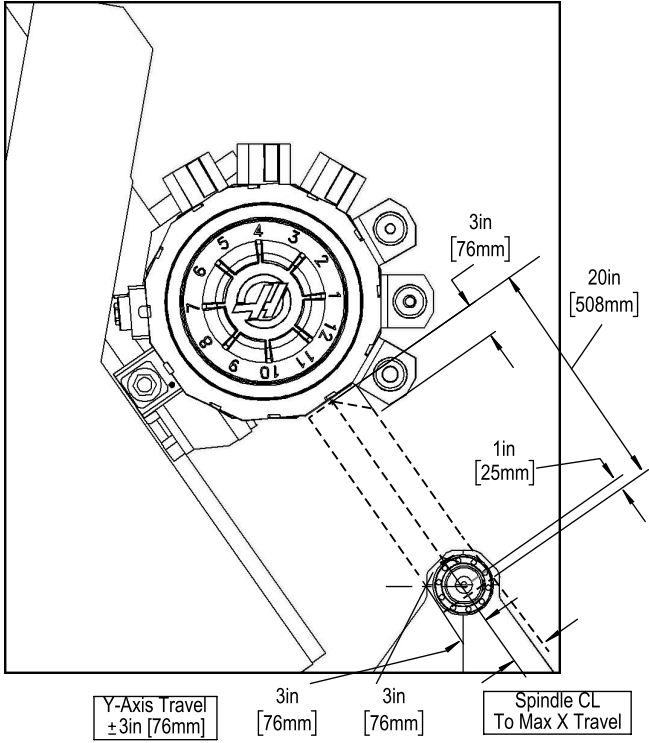

Standard Chuck

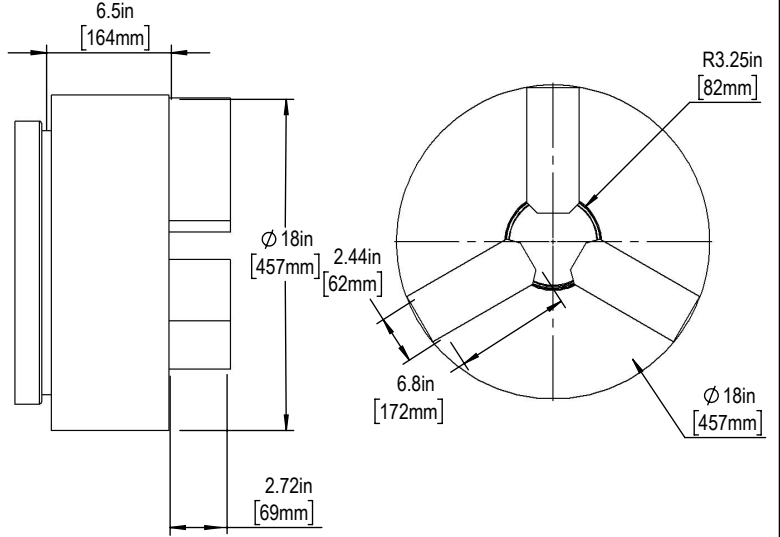

Dimensions may vary per manufacturer

Standard Extended  
Tool Pocket

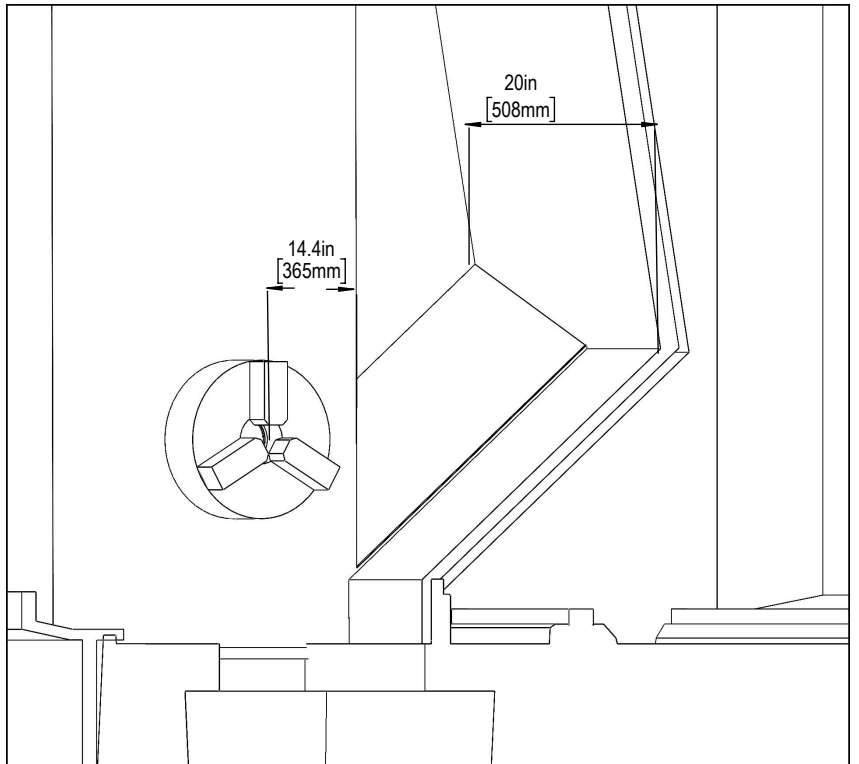
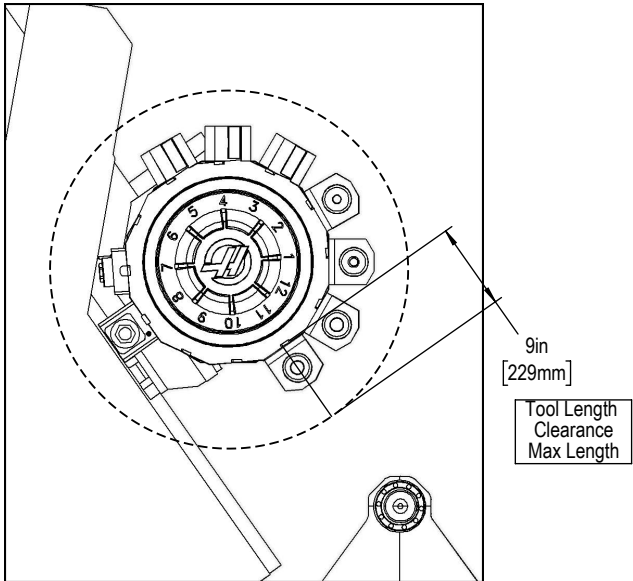

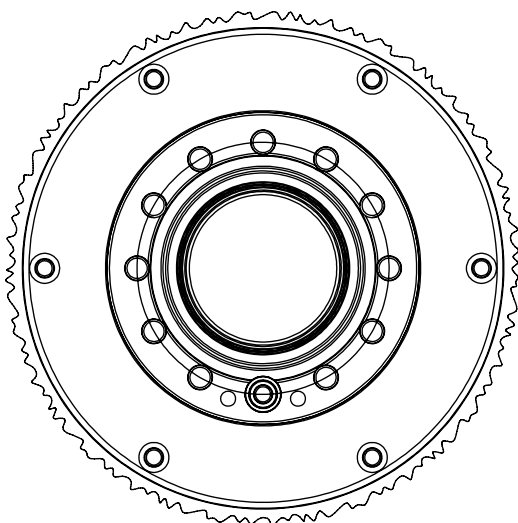
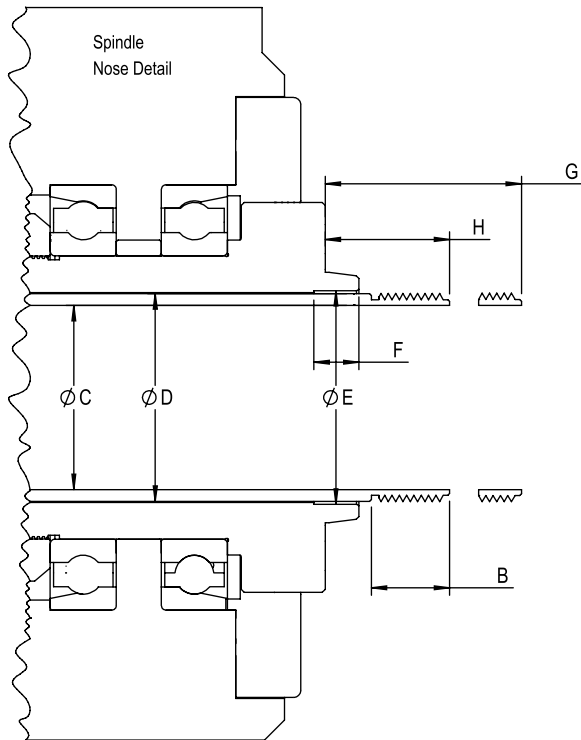
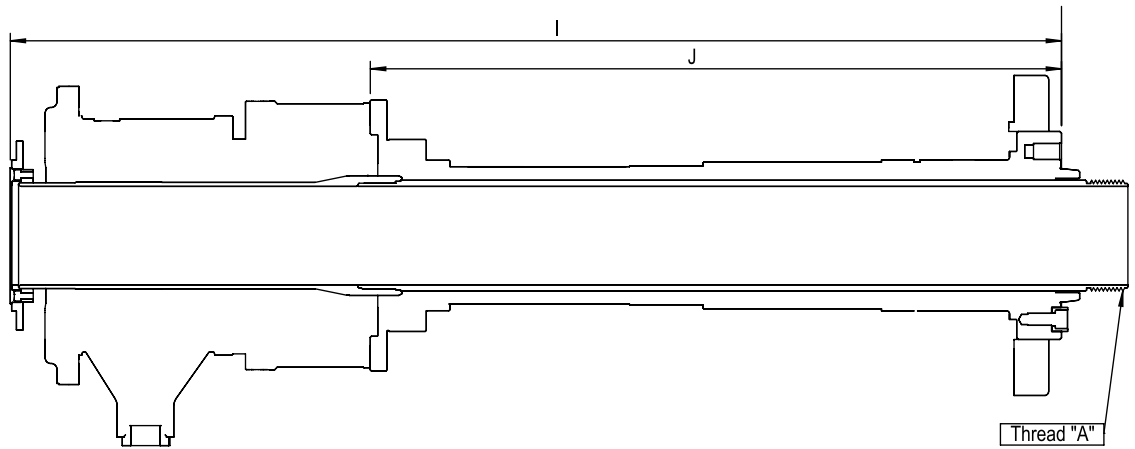

Description	DIMENSION PARAMETER	ST-45/Y	
		SAE (in)	METRIC (mm)
SPINDLE TYPE		A2-11	
THREAD TYPE	A	M175 X 3.0	
INTERNAL OR EXTERNAL		EXTERNAL	
LENGTH OF THREAD	B	3.03	76.96
DRAWTUBE INTERNAL Ø	C	6.51	165.35
DRAWTUBE EXTERNAL Ø	D	7.02	178.31
COUNTERBORE INTERNAL Ø	E	N/A	N/A
COUNTERBORE DEPTH	F	N/A	N/A
DRAWTUBE EXTENDED	G	3.02	76.71
DRAWTUBE RETRACTED	H	1.84	46.74
SPINDLE FACE TO BACK OF UNION	I	48.3	1226.82
SPINDLE FACE TO UNION ADAPTOR	J	32.7	830.58

\*Due to vendor variations discretion should be taken to verify validity of provided dimensions