

UMC-500 + APL WITH NO FENCE

TOP VIEW

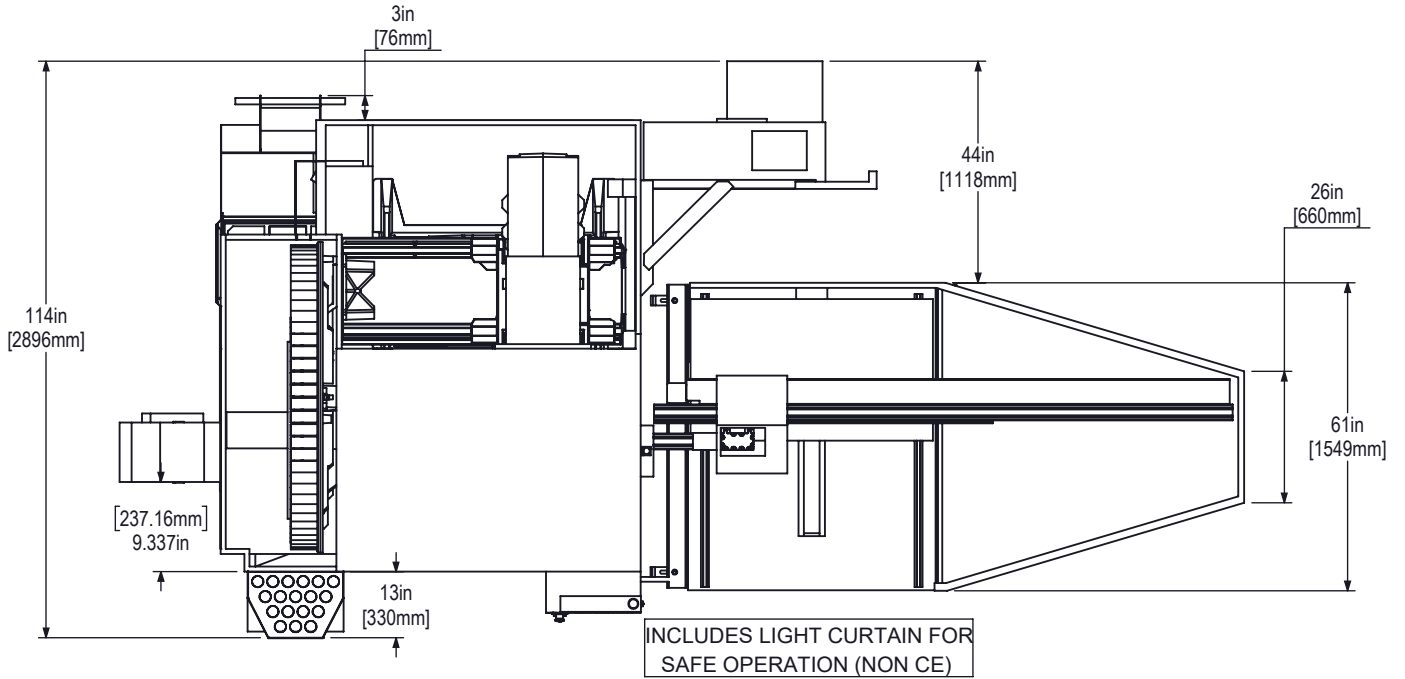

FRONT VIEW

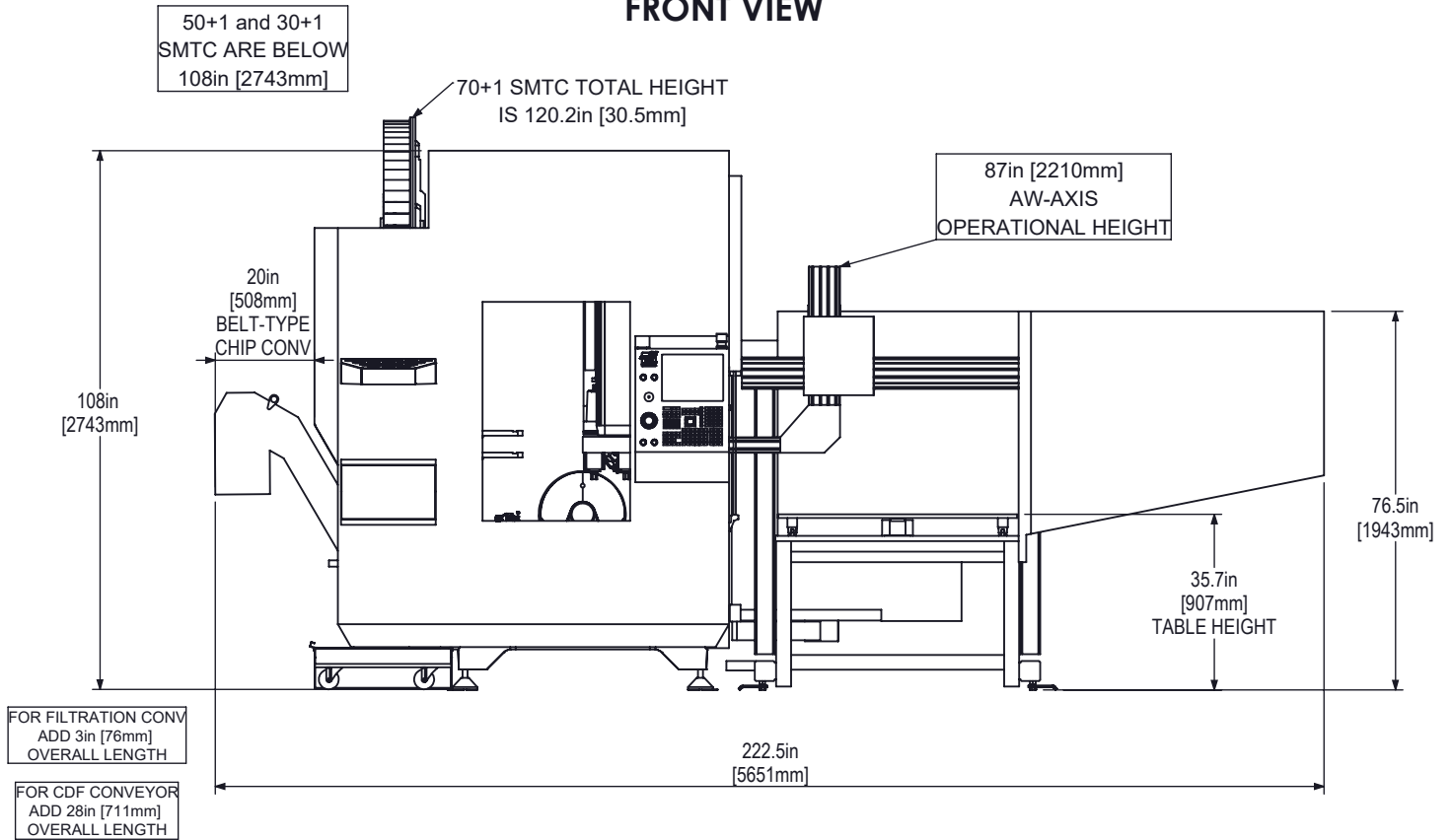

REFER TO UMC-500 LAYOUT DRAWING FOR MORE DIMENSIONAL DETAILS



UMC-500 + APL WITH FENCE

TOP VIEW

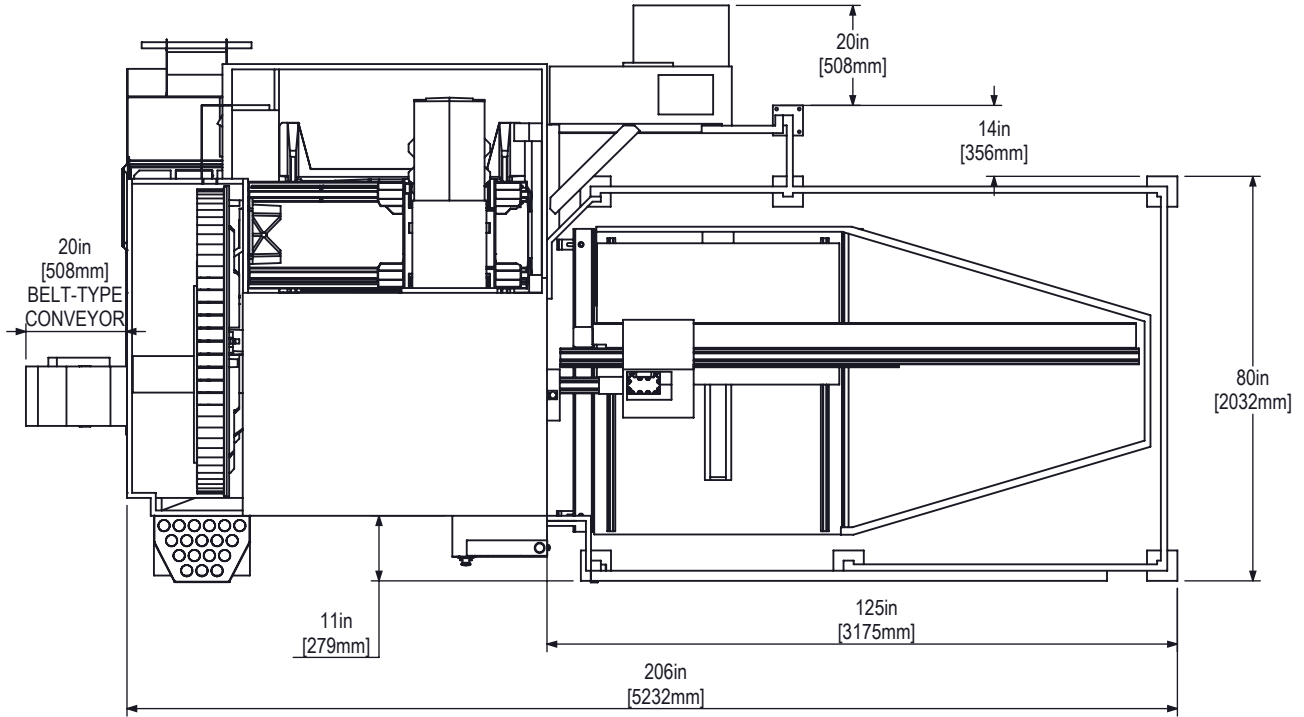

FRONT VIEW

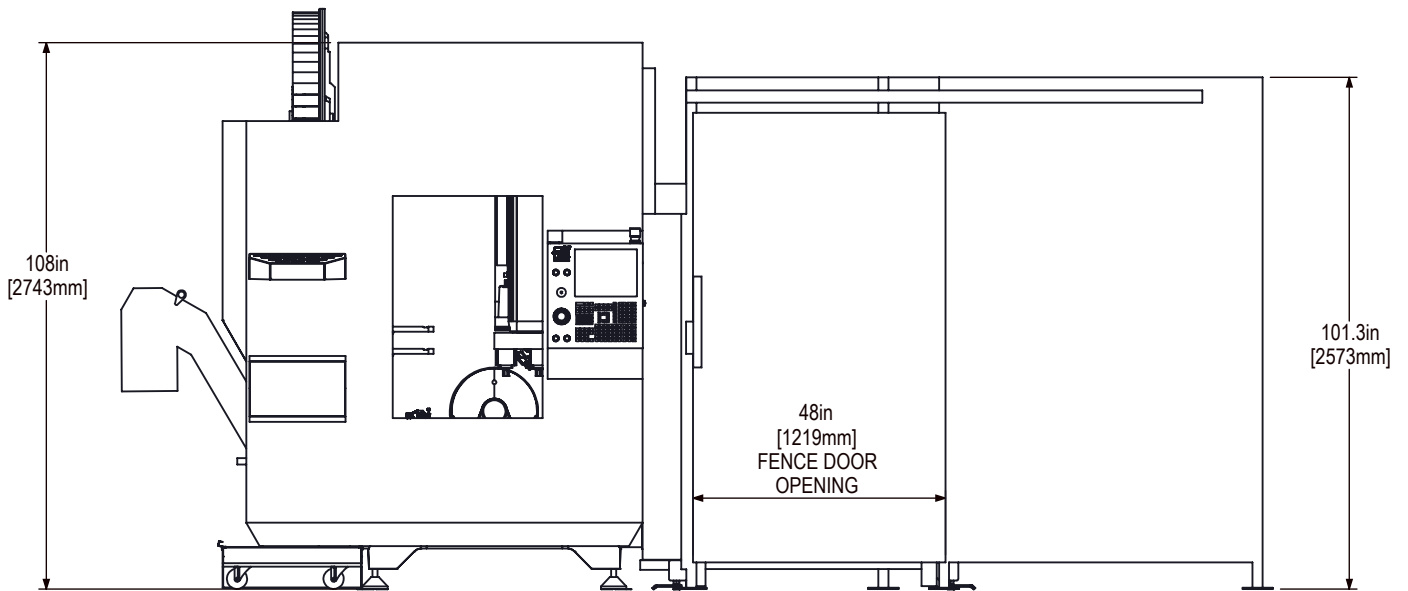

LIGHT CURTAIN NOT INCLUDED
FOR CE MACHINES WITH FENCE

REFER TO UMC-500 LAYOUT DRAWING FOR MORE DIMENSIONAL DETAILS

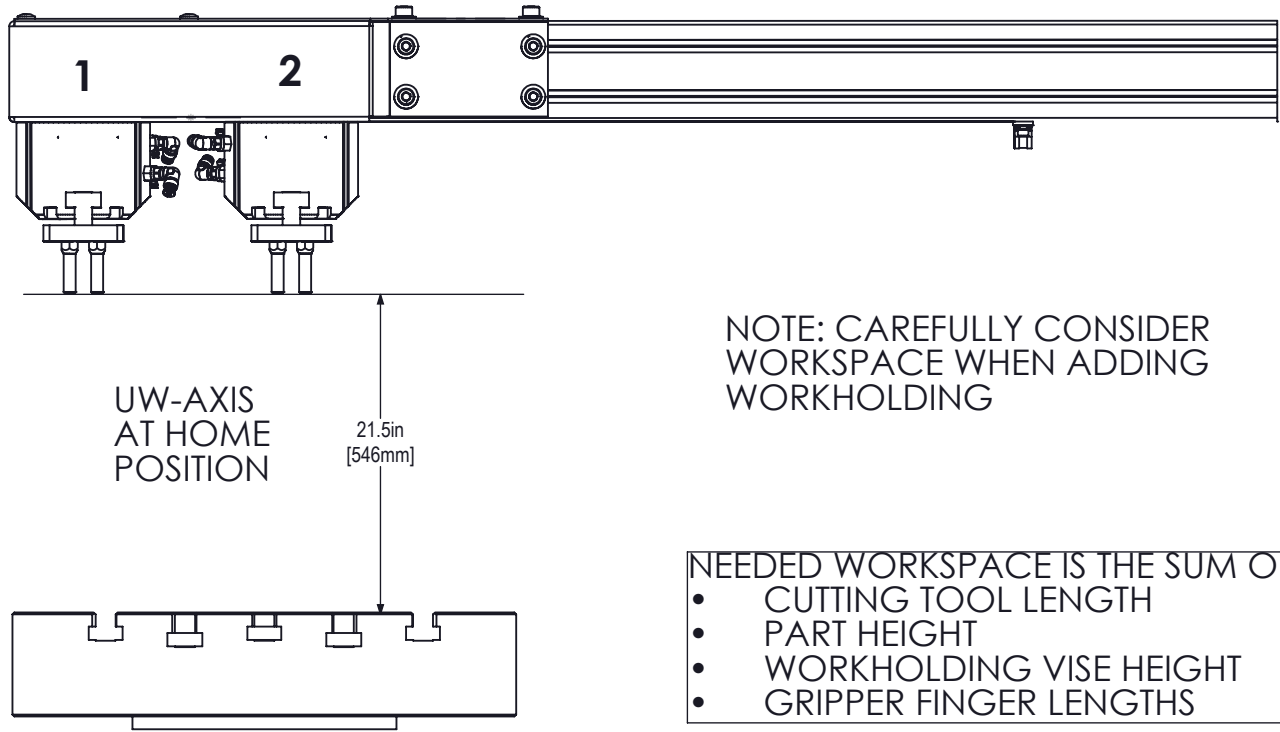

ALL THREADED HOLES ARE IN INCHES
5/16-18 UNC-2B

PLATES SHOWN IN THE CLOSED POSITION

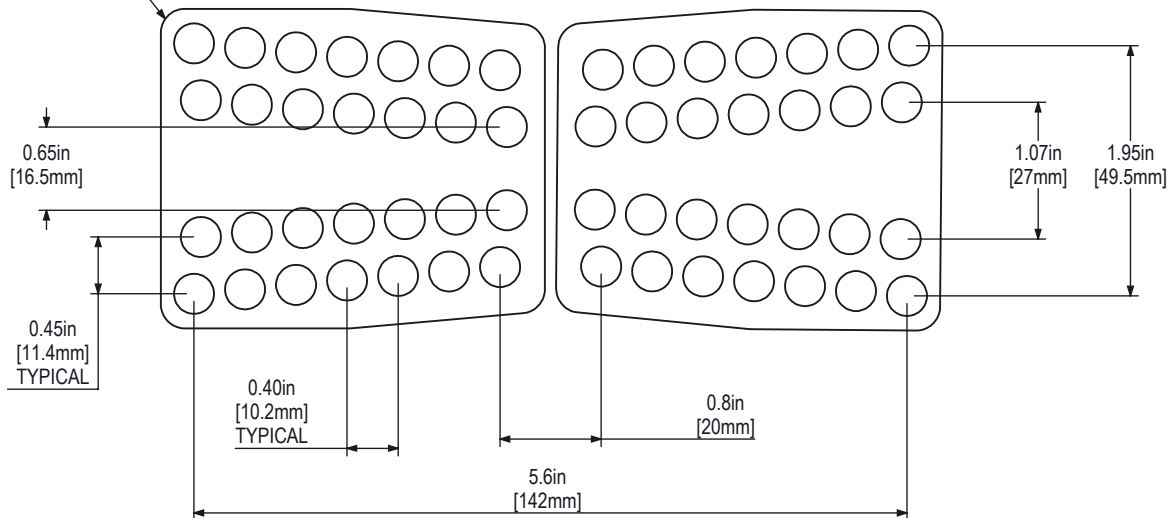

EACH GRIPPER PLATE HAS 28 THREADED HOLES FOR FINGER PLACEMENT AS NEEDED

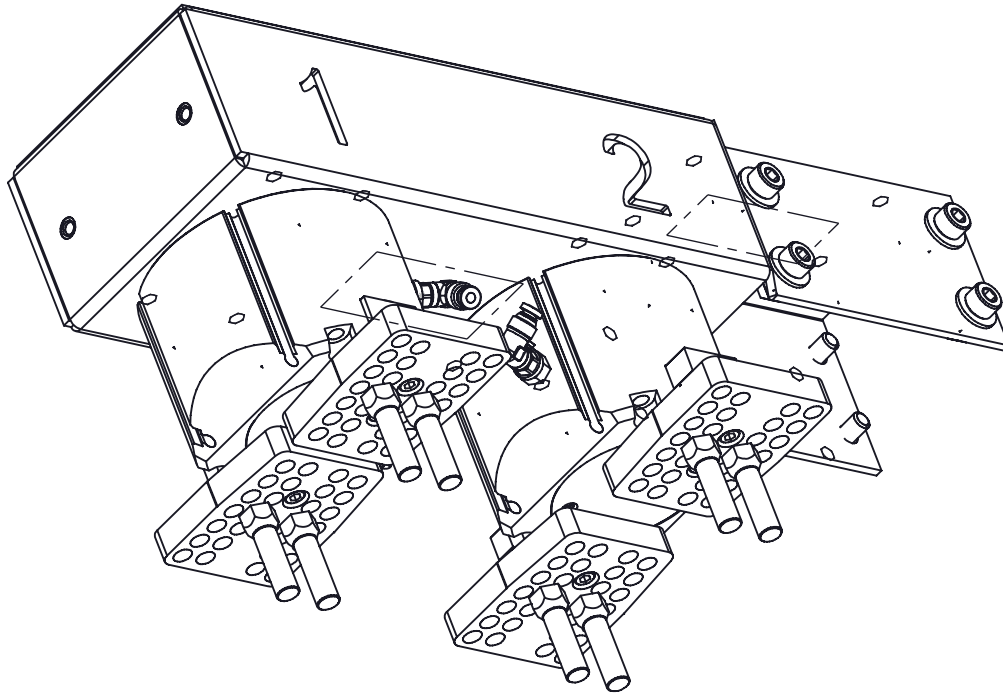

**FINGERS CAN BE MOVED TO OTHER THREADED HOLES
TO ACCOMODATE VARIETY OF PART SIZES**

FRONT VIEW

SIDE VIEW

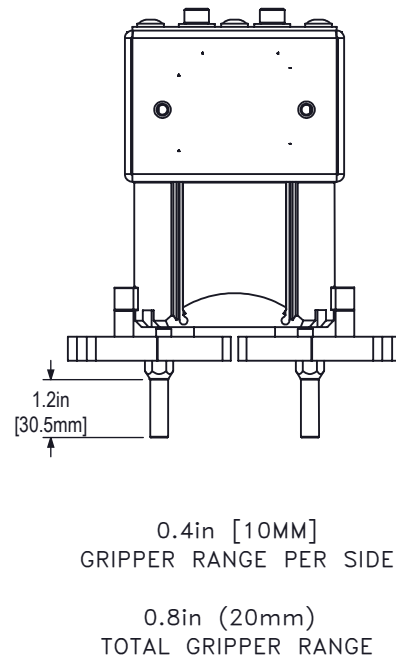
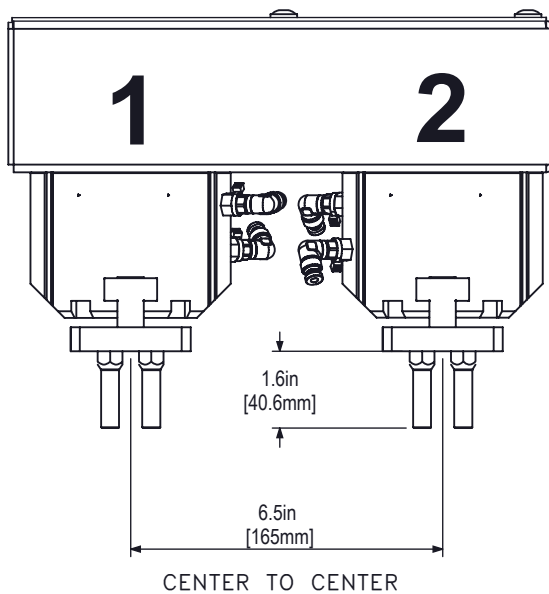

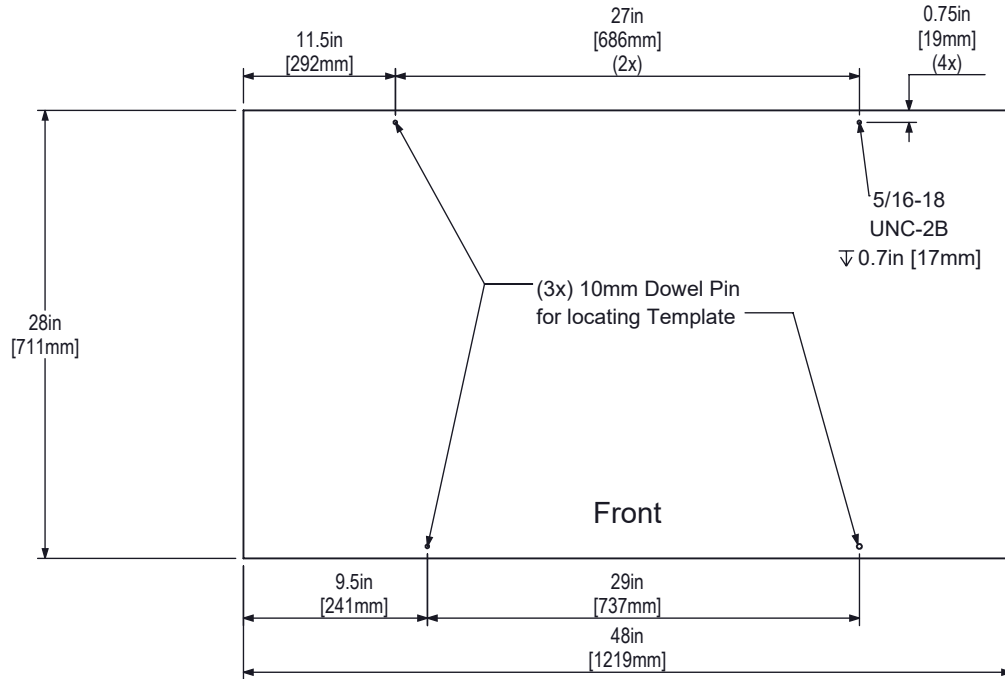

To accommodate the large variation in size and shape of material that can be loaded by the APL, use the following guidelines and table dimensions to make your own part specific templates

1. Allow adequate space between rows and columns for gripper clearance
2. All rows must have equal spacing
3. All columns must have equal spacing (but can be different than row spacing)
4. Use dowel pins and/or screw holes to fix template to table

MAXIMUM PART SIZE

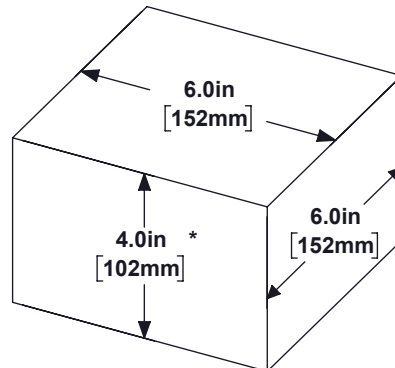

MAXIMUM PART WEIGHT
10lb [4.5kg]
Per Gripper

*Maximum height assumes factory included Grippers.
Using other workholding will change the maximum part height