

Leveling Pad Detail

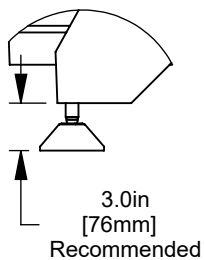

Shipping Dimensions

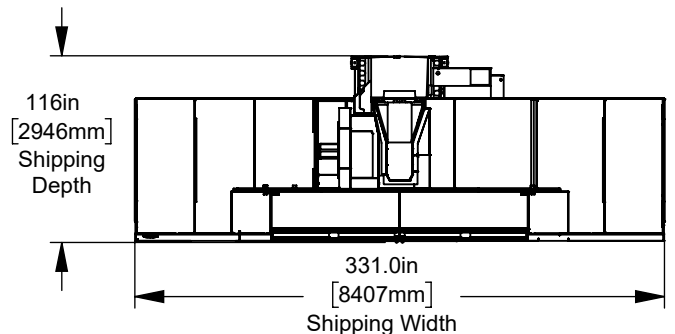
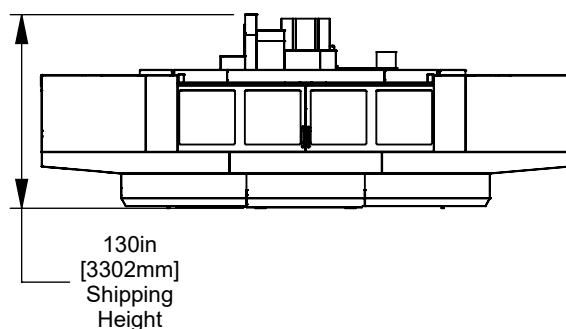

Air & Power

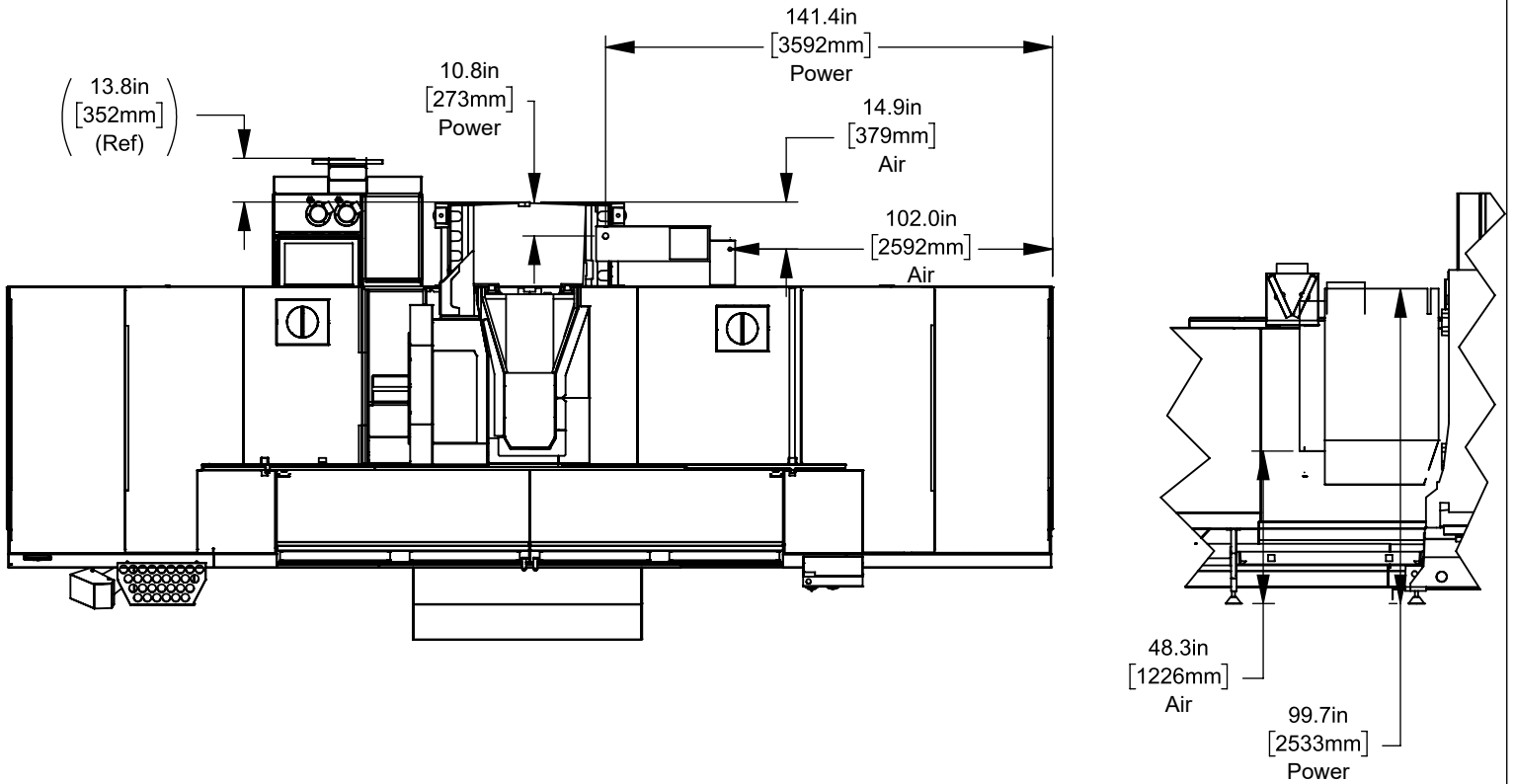

**Anchor Detail**  
 Ø .625in [16mm]  
 ▽ 2.0in [50mm]  
 2.25 [57mm]

Anchor Pattern

Note: for Machines built after Sept 2023

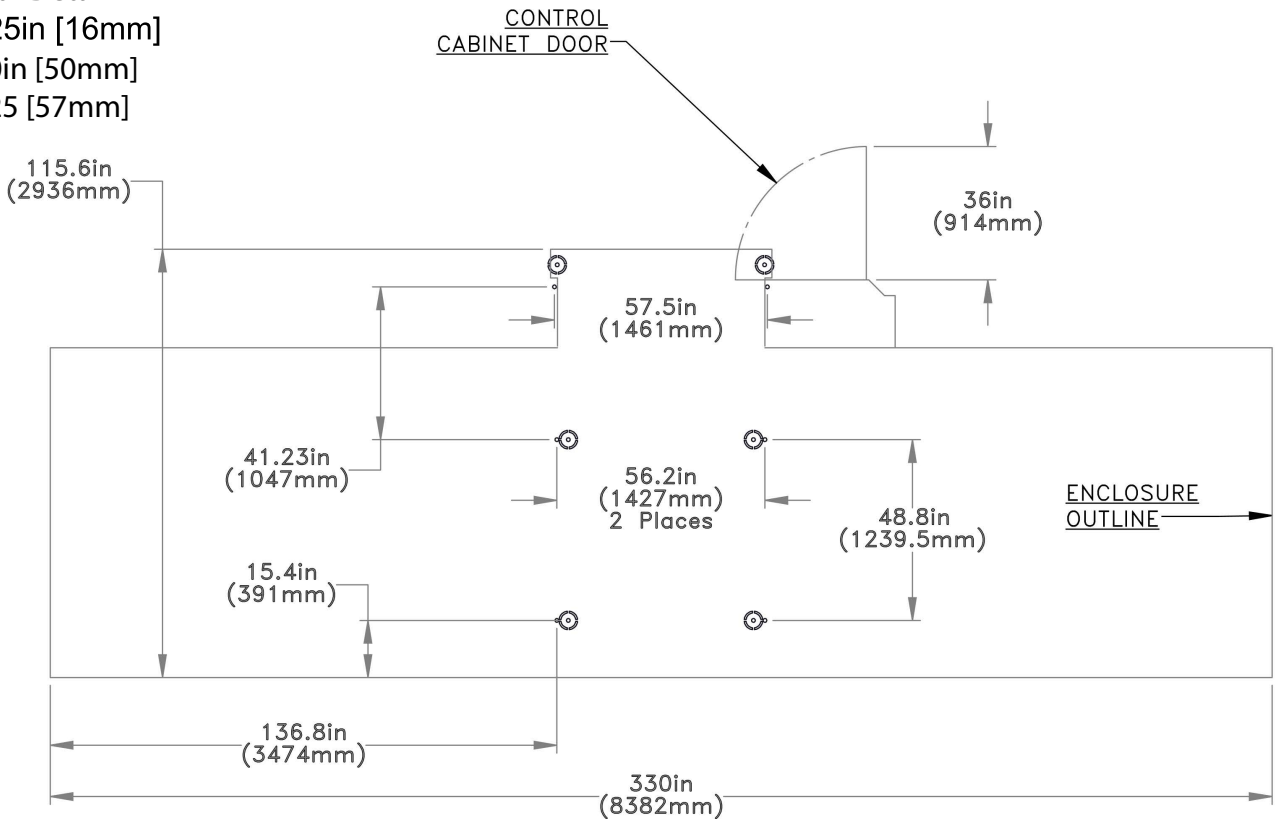

Note - Machine must be placed on one continuous slab.  
 Slab to extend 12" [305mm] beyond all leveling feet

Anchor Patter for Cast/Hammer-In anchors with 3.15" [80mm] Leveling pad center to anchor bore hole center distance

Height Breakdown

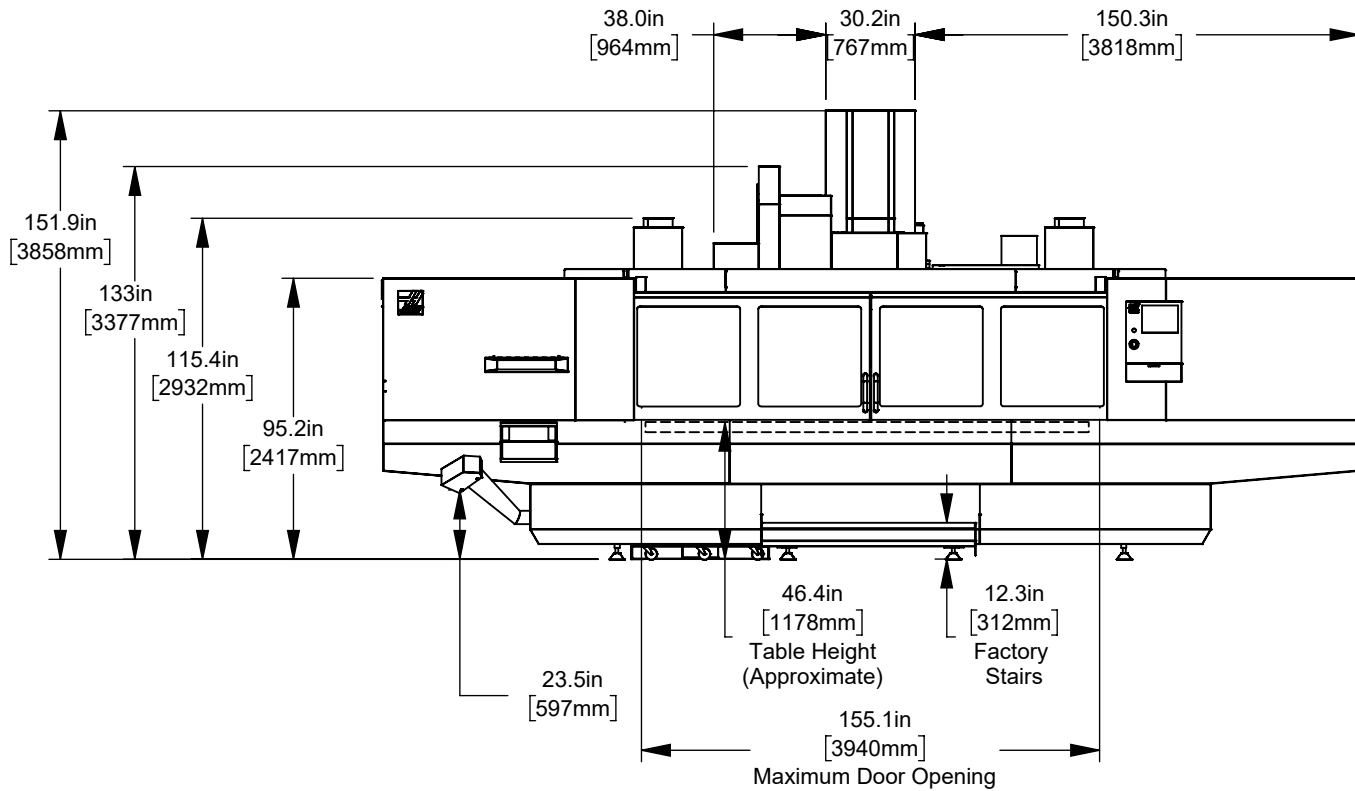

Width and Depth Breakdown

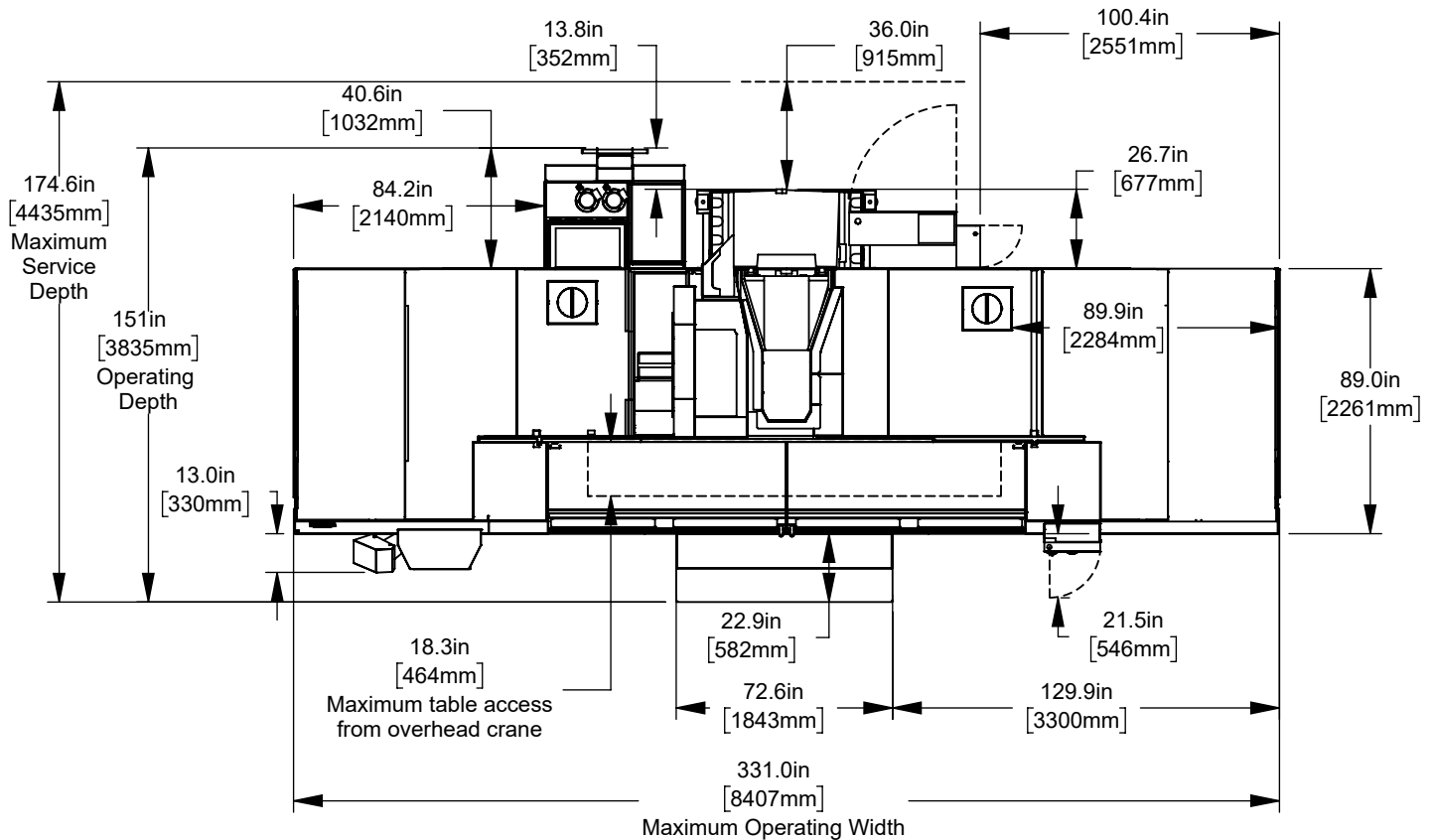

Maintain 3 feet [915mm] clearance to the nearest obstruction around all sides of machine perimeter for maintenance access

X & Y-Axis Travel at B0

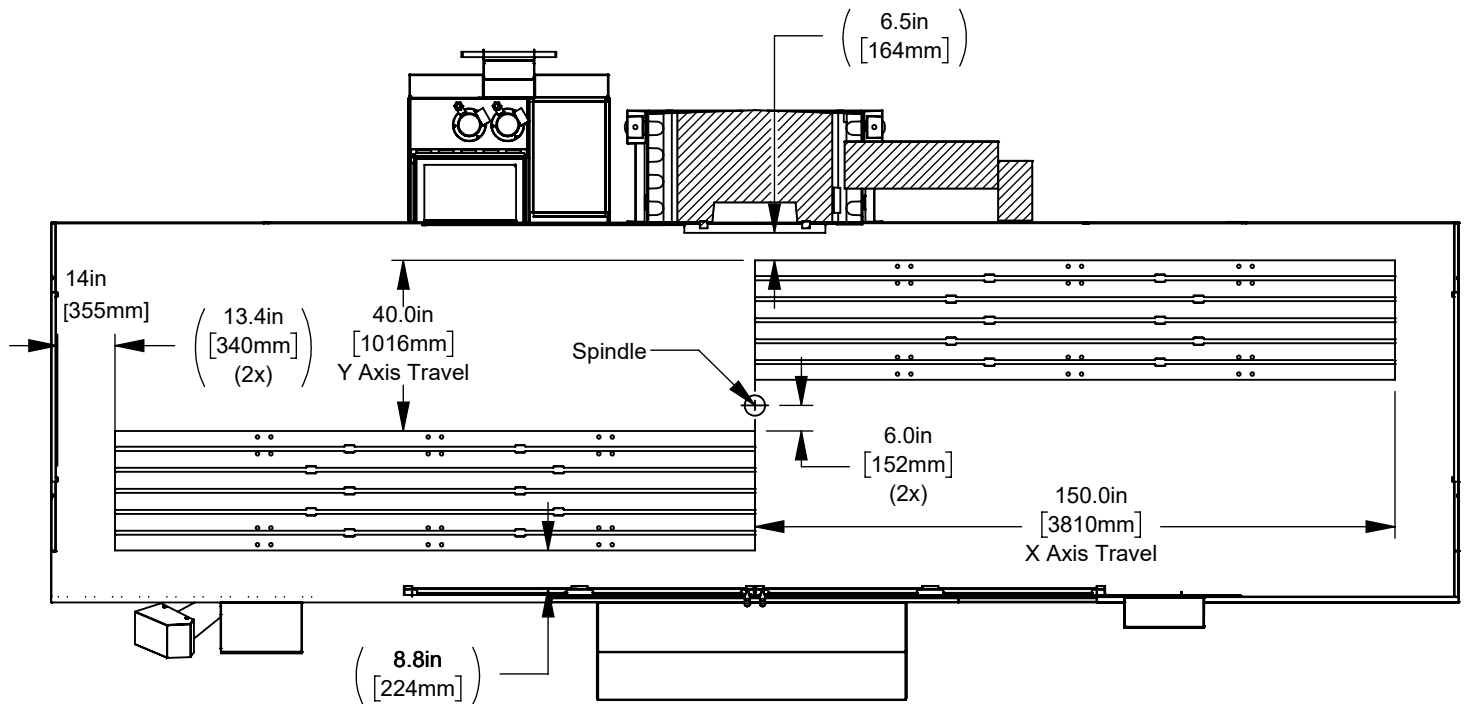
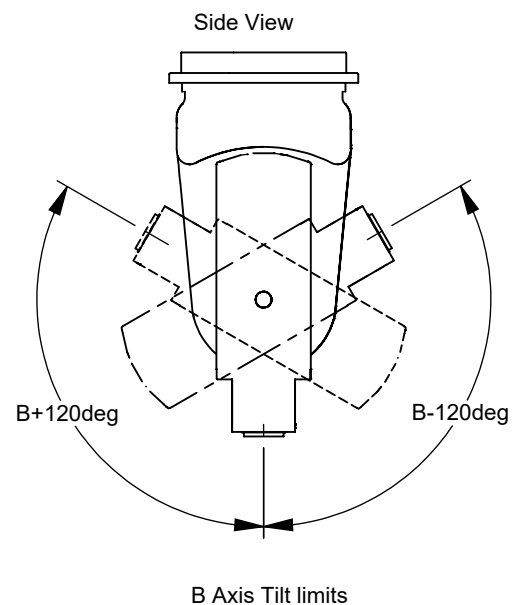
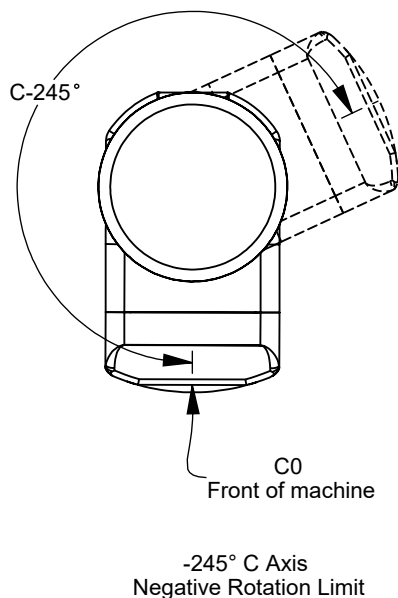
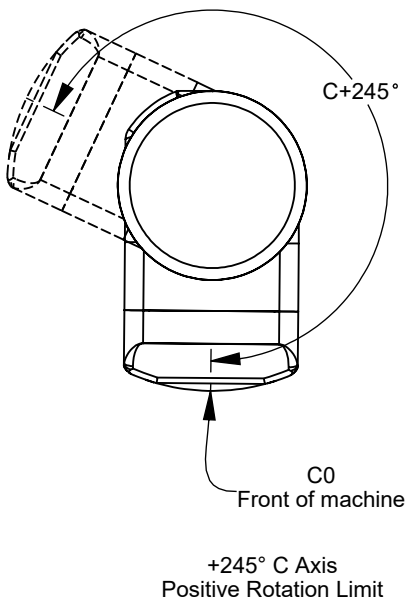

Table:  
150in X 28in  
3810mm X 711mm

Top View STD Spindle Shown

B & C axis Travel

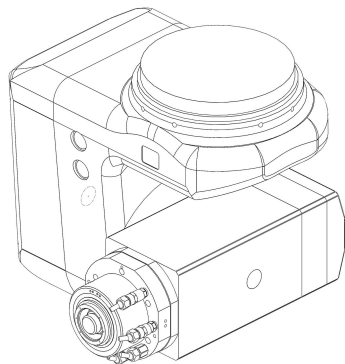
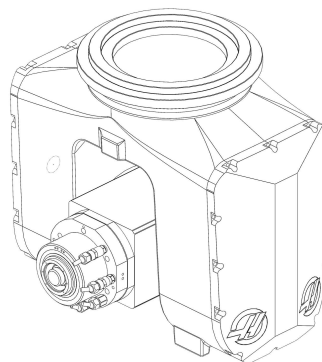

## Isometric views of B &amp; C Axis heads for Visual Reference

Gimbal  
Single SupportYoke  
Dual Support

X&Y-Axis Clearance at B90 with C at 0, 90, -90, and 180  
(Measurements applicable to both Single and Dual Supports)

## Notes -

The schematic above shows the B90° work envelope with no tool in the spindle.

Depending on the part size and how many faces require machining, the part may need to be centered or offset to one side of the table.

Subtract (the longest tool length required on each side of the part) + (clearance) from the travels shown below to determine the maximum size workpiece based on your tooling requirements

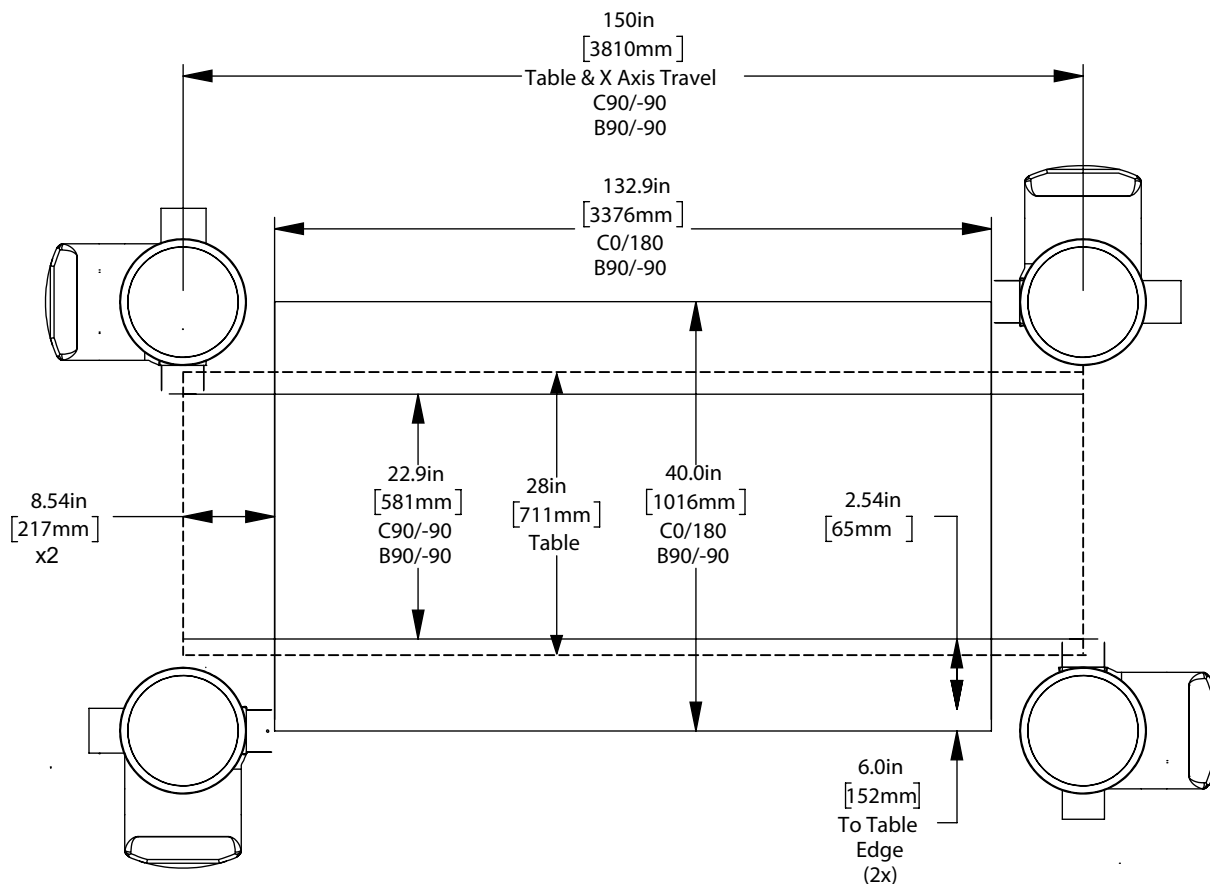

Table

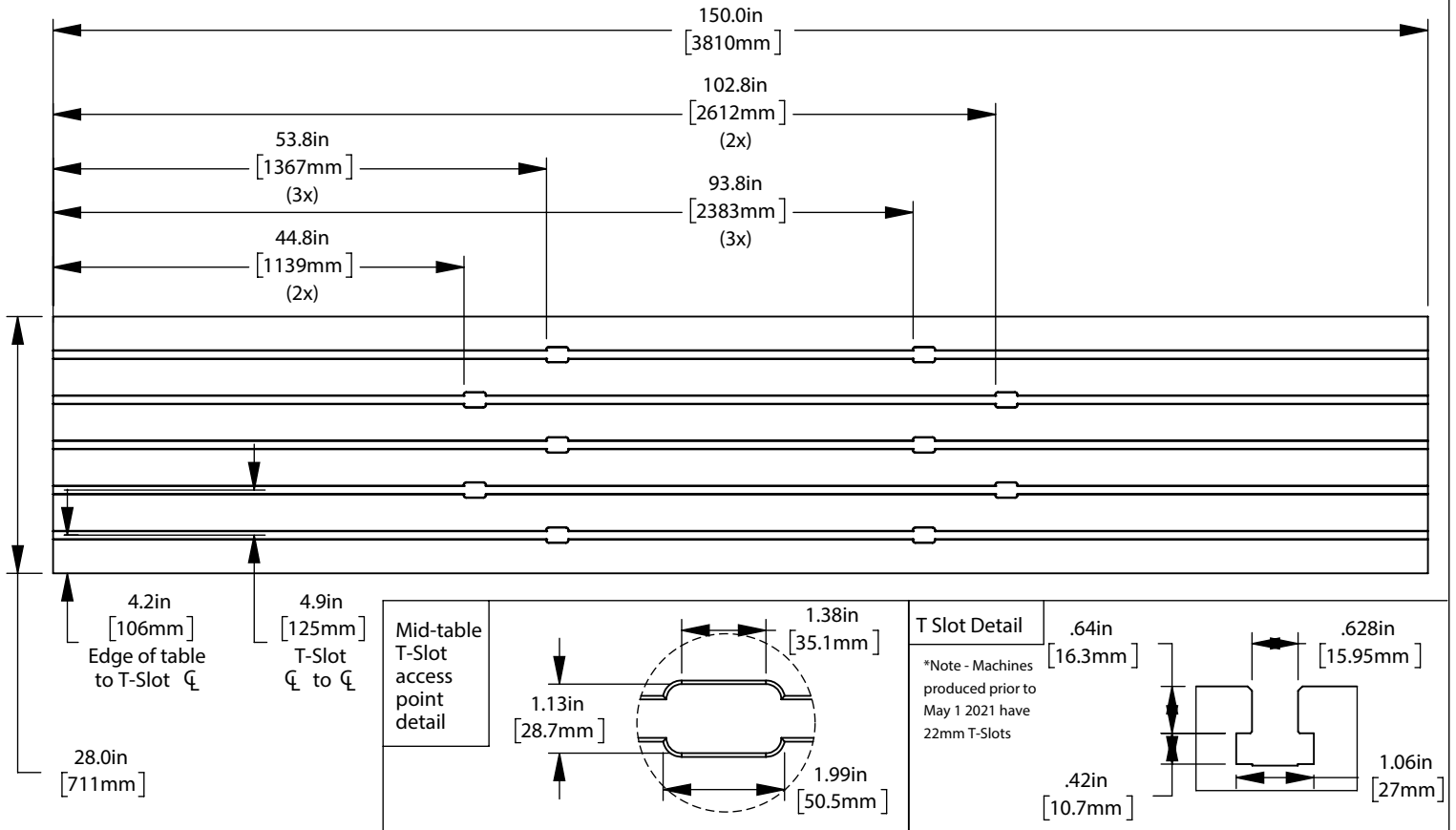

Tool Changer and Z Travel

Measurements apply to both Standard and Dual Support except where noted

\*STD Spindle (Gimbal)  
\*\* Dual Spindle (Yoke)

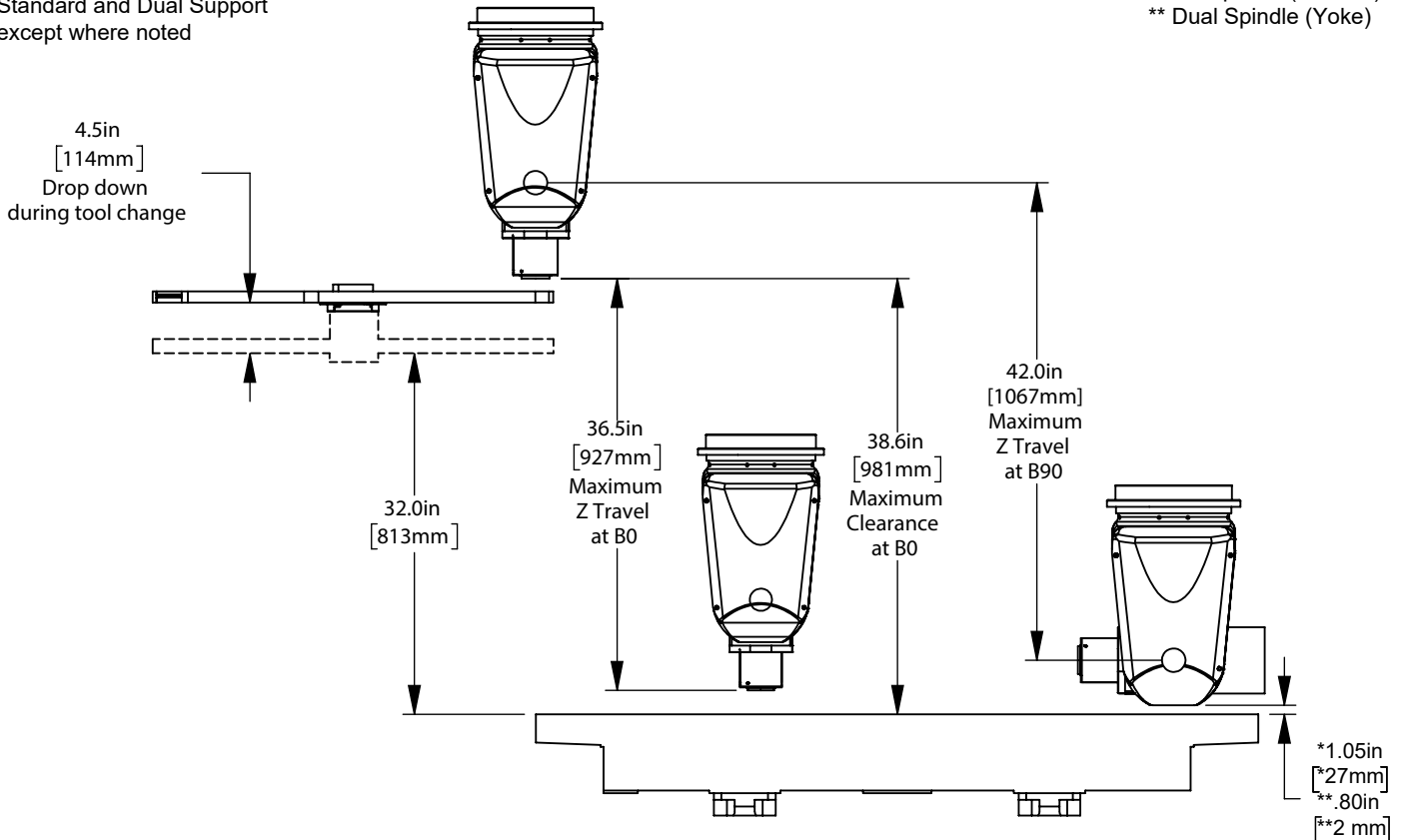

**NOTE- Spindle must be empty before Powerup/Restart is performed or the B axis may crash the tool changer**

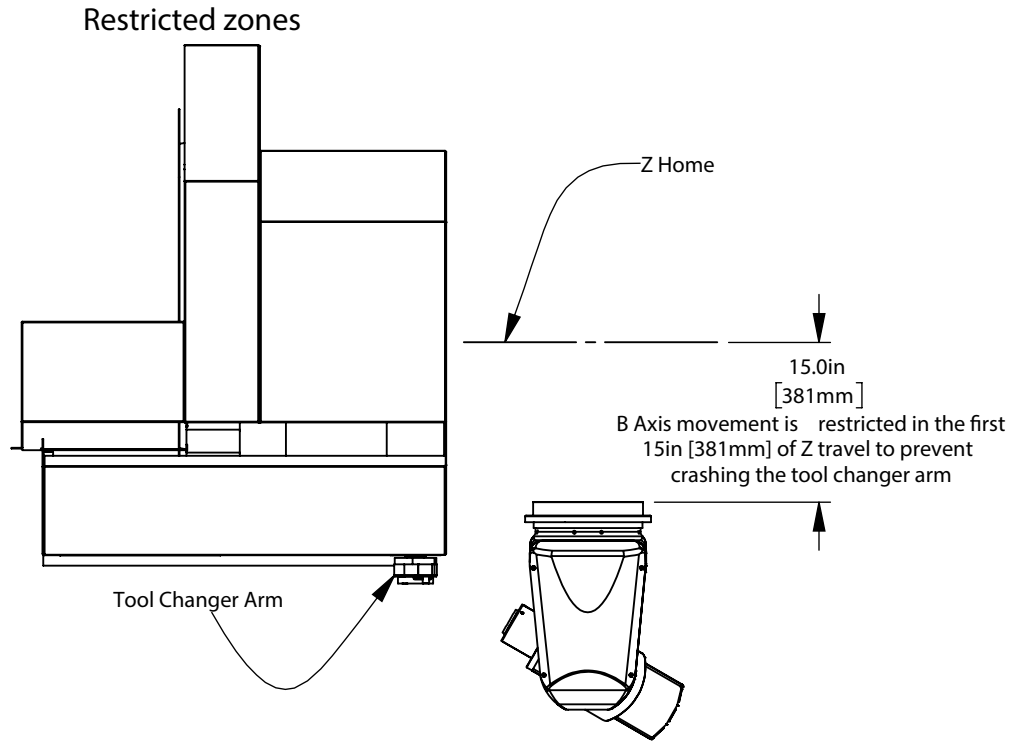

In addition to the tool changer interference zone, the machine has restricted zones between the gimbal head and fixed machine elements  
 When Setting 408 = 1 the interference zones account for the tool length based on its Z geometry in the offset table  
 When Setting 408 = 0 the tool length is not considered in the interference zones

Potential interference at maximum Z travel with Z axis casting

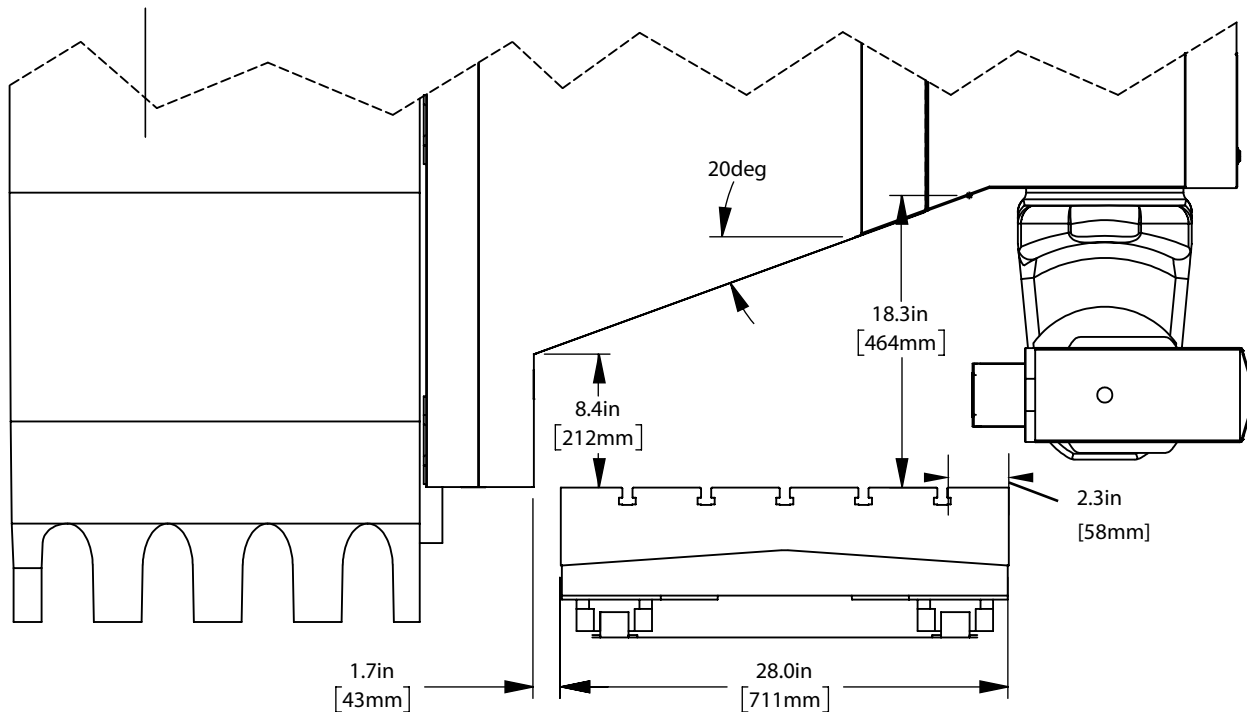

**Minimum Z height to reach B120°**

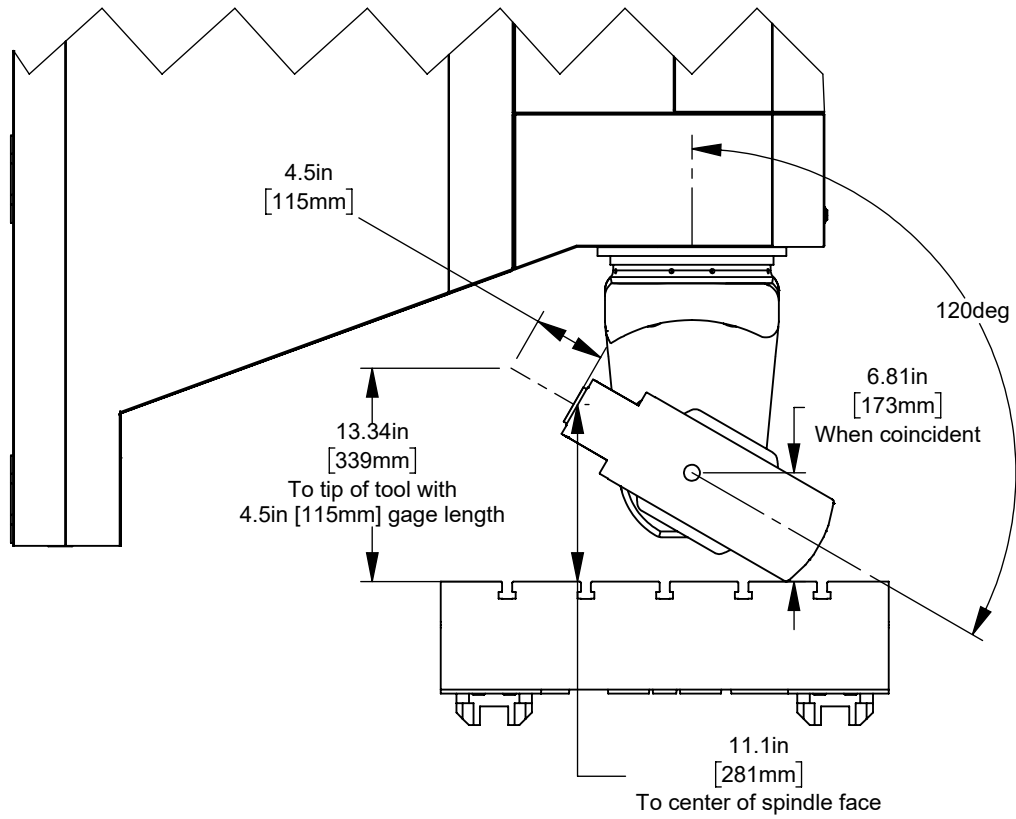

**Gimbal Head Details**

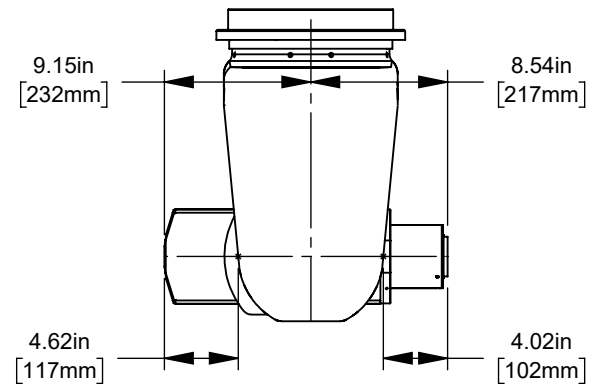
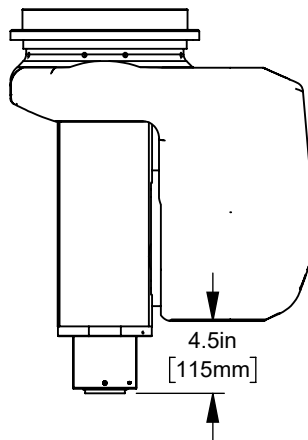
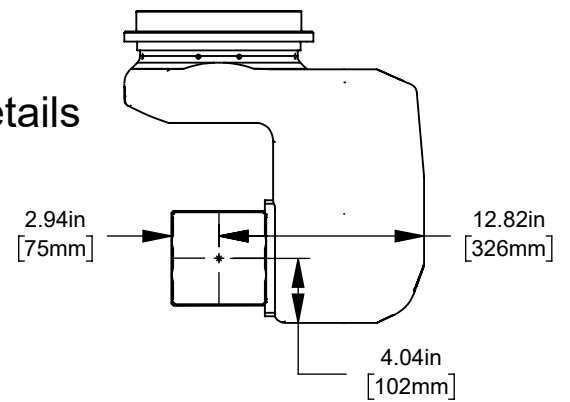
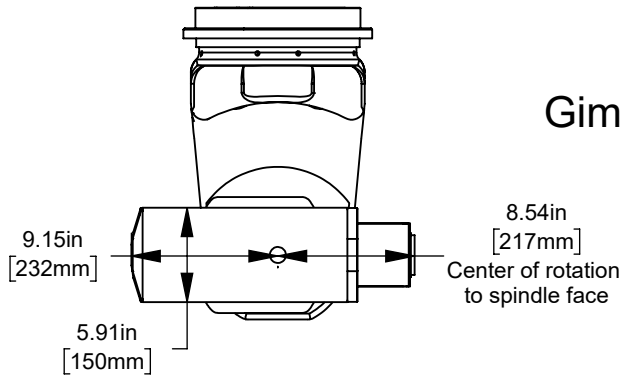



### Dual Support Yoke Head Details

